

SV-4328 / SV5128 / SV6332 OPERATION MANUAL



Chapter 1 SAFETY

1.1 Safety Precautions	10
1.2 Warning Labels	10
1.3 Utilization Of Safety Device	16
1.4 Warning Lists	17

Chapter 2 Preparations For Installation

Overview	22
1. Preparation Of Set-up Area	23
2. Preparation Of Transport Route	27
3. Preparation Of Transportation Equipment	28
4. Set-up Conditions	29
5. Air/Power Sources	30
6. Recommended Foundations	32

Chapter 3 OPERATION

Before Starting Operation / Operation Flowchart	37
1. Main Operation Panel	38
1.1 Main Operation Panel Functions	38
1.2 LCD Control Panel Functions	58
1.3 Displaying PC Screen	62
2. M_CODE	65
2.1 M - c o d e L i s t	65
3. Setting/Changing Machine Parameters	67
4. Opening / closing Doors	71
4.1 Opening / closing Splashguard Door	71
5. Turning On/Off Power Supply	74
6. Data Registration / Editing	77
6.1 NC Program Registration (3 Methods)	77
6.2 Tool Offset Registration	77
6.3 Tool Offset Value	80
6.4 Registration Of Workpiece Offset Value	81
7. Workpiece Attachment And Detachment	85
1. Workpiece Attachment And Detachment	85
2. Workpiece Restrictions	86

8. Tool Preparations	87
8.1 Tool Attachment and Detachment	87
8.2 Tool Storage Limitations	88
8.3 Tool And Retention Stud Combinations	88
9. Tool Change	92
10. Cutting Fluid Supply	93
11. Chip Disposal	94
11.1 Operation Of Lift-Up Conveyor	95
12. Automatic Operation	96
1. Program Edit Procedure	96
2. Program Configuration	97
3. Subprogram Call	99
4. Major Function And Address	101
5. Force Mirror Image	102
6. Program Edit	103
7. Add New Program	103
8. Delete Program	104
9. Program commanded Search	105
10. Edit key	106
11. Copy Program	111
12. Graphic Function	117

Chapter 4 PROGRAMMING

1. Commanded Description	137
1.1 G Commanded	137
1.2 F Commanded	142
1.3 S C o m m a n d e d	142
1.4 T Function	145
1.5 G Code Composition	145

Chapter 5 PROGRAM INPUT / OUT OPERATION

1. Memory Card Operation	214
1.1 Displaying The Directory	214
1.2 Searching for a File	215
1.3 Reading A File	217
1.4 Writing Files	219
1.5 Deleting A File	222
1.6 DNC Operation	223
1.6.1 Searching for a File	223
1.6.2 Executing A File	224
2. Data Input/Output On The All I/O Screen	225
2.1 Program Input/Output	225
2.1.1 Program Input/Output	225
2.1.2 Searching For A File	226
2.1.3 Inputting A Program	228
2.1.4 Outputting Programs	230
2.1.5 Deleting A File	232
2.2 Parameter Input/Output	233
2.2.1 Searching For A Parameter	233
2.2.2 Inputting A Parameter	234
2.2.3 Outputting Parameters	236
2.2.4 Deleting A Program	237

Chapter 6 CUTTING TOOL CONDITION LIST

1. Cutting Tools use Description	239
1.1 Face Mill	239
1.2 End Mill	240
1.3 Boring Bar	241
1.4 Drill	242
1.5 Reamer	243
1.6 Tap	244

Chapter 7 PARTS MANIUL

1. Spindle head	246
2. Column	250
3. Base	254
4. Saddle & Table	258
5. Lubrication	262
5.1 Saddle Distributor	262
5.2 Table Distributor	264
5.3 Spindle Distributor	266
5.4 Auto lubrication system	268
5.5 List of recommended lubricants for parts	270
6. Spindle	271
7. Magazine	277
1. main body	278
2. Tool disk	281
3. Cylinder mounting plate	281
4. Arm Body	282
5. Cam box	283
8. Pneumatic system	289

Chapter 8 APPENDIX

1. Replacing fuse on control unit	295
2. Replacing battery	296
2.1 When a lithium battery is used - Replacement procedure	297
2.2 When alkaline dray cells (size D) are used – Replacing the battery	300
2.3 Battery for separate absolute pulse coder (6VDC)	301
2.4 Battery for absolute pulse coders Built into the built Motor (6VDC)	302
3. Replacing fan unit	302
3.1 Replacement procedure	303
4. High Speed High Accuracy Machining Control Function	304
4.1 AI Advanced Preview Control (AI-APC)	304
4.2 AI NANO Contour Control (AI NANO CC)	305
4.3 AI NANO High Precision Contour Control (AI NANO HPCC) (Optional Function)	306
4.4 Conditions for High Speed High Accuracy Control	308
4.5 Alarm Message	309



4.6 NURBS Function (Optional Function)	310
4.6.1 Features and Advantages	310
4.6.2 Definition	311
4.6.3 Format	312
4.6.4 Notation	313
4.6.5 Example	314
5. Rotary table Interface Install Description	315
5.1 Interface Detail	315
5.2 Parts Description	316
5.3 Terminal Block Input Wires	317
5.4 Operation	319
6. Tool Setter Probe Install	320
7. Compact Touch Probe	353



MACHINE TYPE

MACHINE SERIAL #

CONTROL TYPE

ALL RIGHTS RESERVED . NO PART OF THIS DOCUMENT MAY BE REPRODUCED, COPIED, OR MODIFIED IN ANY FORM OR ANY MEASNS WITHOUT DIRECT PERMISSION OF **SHARP MILLING MACHINES**.

ALL SPECIFICATIONS AND DESIGNS ARE SUBJEC TO CHANGE WITHOUT NOTIFICATION.

INTRODUCTION

This manual is for this vertical machining center



Read this manual prior to beginning any maintenance or repair work .
Follow the instructions provided in this manual to ensure the safety of those maintaining or repairing this machine .
Disregarding or not following the specific directions in this manual may lead to serious Injury or death .

IMPORTANT NOTICE

1. Read and understand Chapter "1. SAFETY " prior to machine operation to ensure safe working Conditions.
2. Designate specific operators for this machine to ensure optimum machine performance and safety standards are maintained at all times .
3. Keep this manual in a clearly marked location to ensure Easy access when necessary .
4. Contact the regional SHARP office or local distributor if this manual is lost or damaged .
5. Reproduction of this manual in part or in its entirety is prohibited by SHARP .
6. Ensure this is included when moving or reselling this machine .
7. All specifications and designs are subject to change without prior notification .

SYMBOLS IN THIS MANUAL	
	Supplementary explanations
	Explains operation errors that will cause Alarm or stop the machine .
	Explains convenient functions to be used during operations .
	Indicates reference items, figures and tables providing further information

Chapter 1 SAFETY

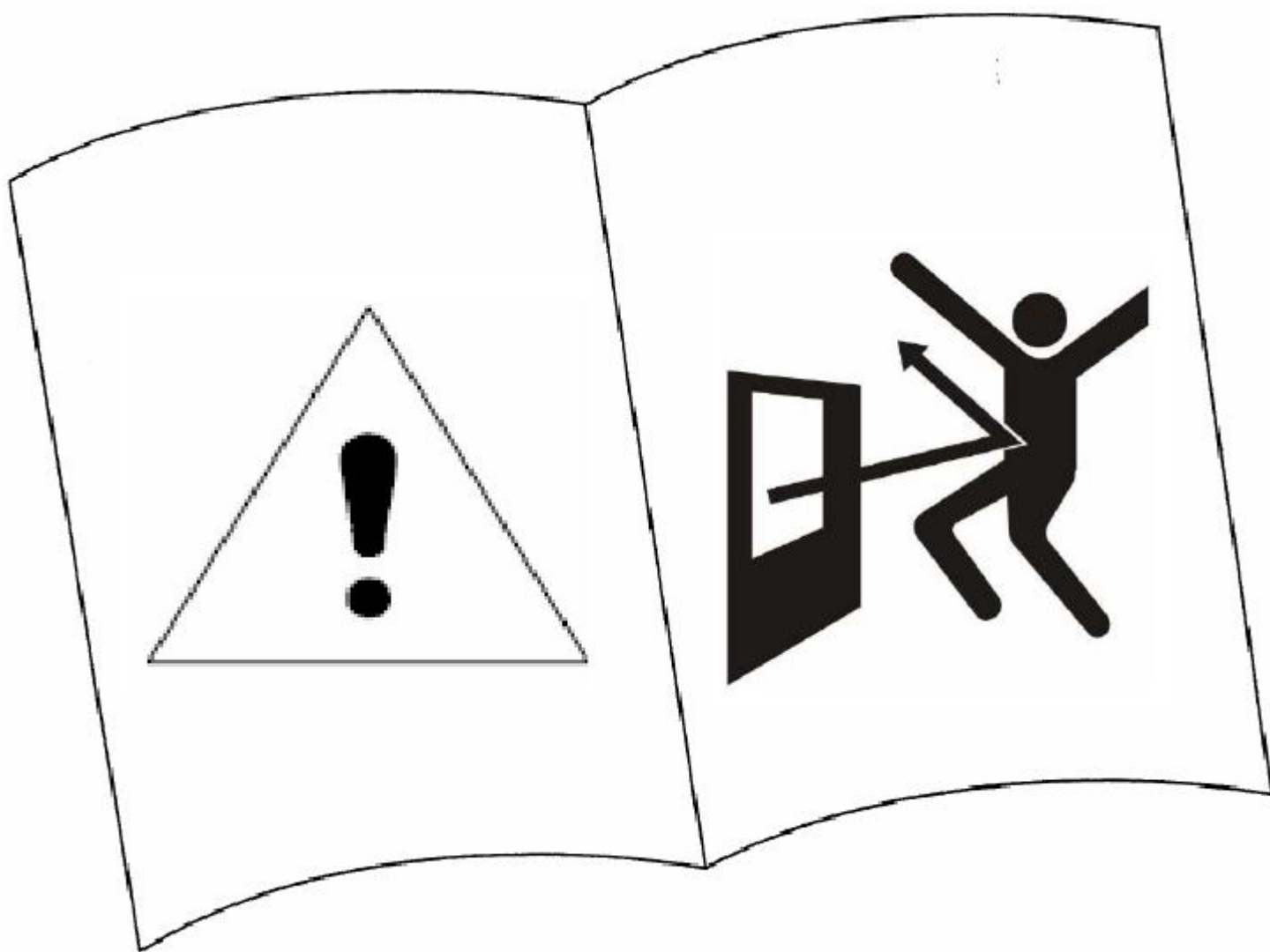

1.1 Safety Precautions

Safety precautions and special considerations relevant to all machining operations must be thoroughly understood by the operator prior to machine operation . Careless use of the machine may result in serious Injury and machine damage .

1.2 Warring Labels

The warring labels attached to machine at specific points identify safety risks and provide important instructions that must be followed ( Figure 1.1 ~ Figure 1.5)

Warning labels are divided into 3 categories according to

levels of caution required ( Table 1.1)

Table 1.1 DANGER / WARNING STATEMENTS

	Failure to heed this warning will Lead to death or serious injury .
	Failure to heed this warning may cause working conditions Lead to death or serious injury .
	Failure to heed this warning may cause working conditions Lead to minor injury or machine damage



Order new labels from the nearest sales office and affix in original position after the following :

- When the warning labels peel off
- When the warning labels become illegible
- When the parts on which the warning labels are attached are replace .

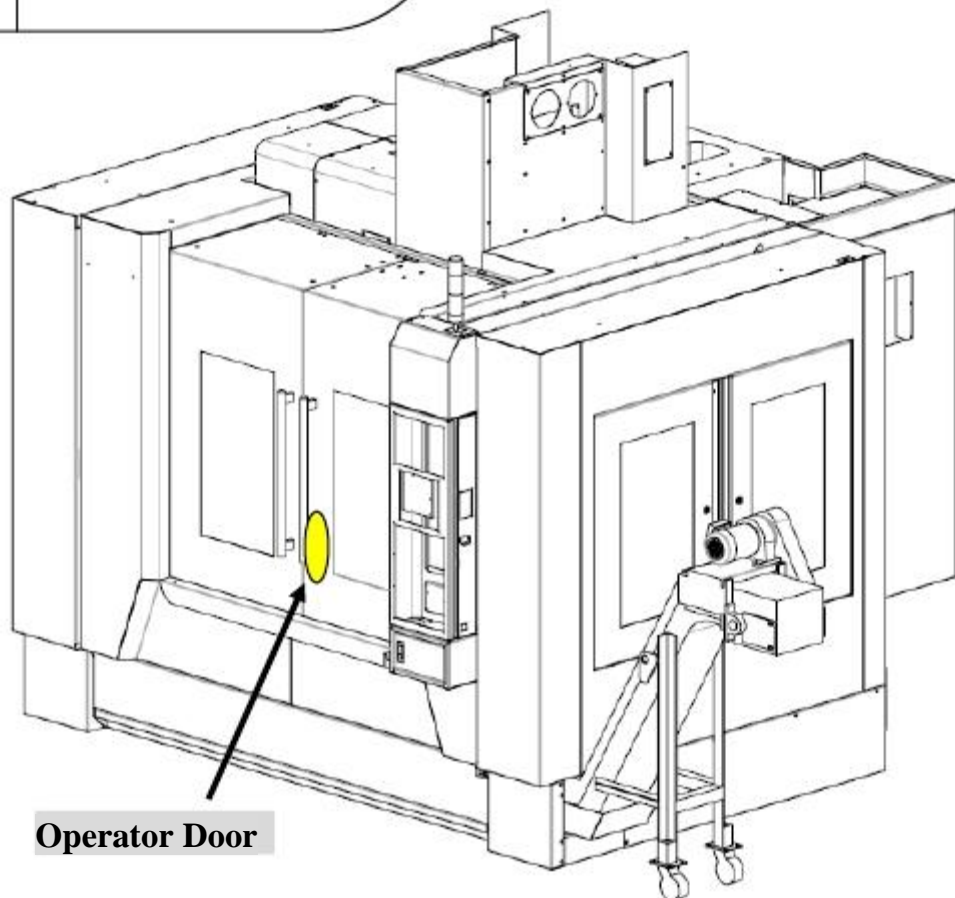

Figure 1.1 LOCATION OF WARNING LABEL

Spindle Running-in Procedures			
Case	Spindle speed(Percentage of max. speed)	Time (min)	Check points
1 Ordinary operation	20%	10	1 Temperature-rise Within 20° C 2 Vibration 3 Noise
2 Spindle rests over 72 hours	1. 25%	10	1 Temperature-rise Within 20° C 2 Vibration 3 Noise
	2. 50%	10	
3 Spindle rests over 2 weeks	1. 20%	15	1 Temperature-rise Within 20° C 2 Vibration 3 Noise 4 Proceed to next stage after temperature stabilizes
	2. 40%	15	
	3. 60%	30	
	4. 80%	30	
	5. Max. speed	40	

(1) Start the spindle after a tool is clamped in spindle

Warning

(2) If temperature-rise is over 20° C, reduce spindle speed to 800rpm, then restart the procedure after the spindle temperature has cooled off to within 5° C above the ambient temperature.



SAFETY INSTRUCTIONS

1. Read and understand Operator's Manual and all warnings on the sign before operating. Failure to follow these instructions and warnings can result in serious injury or death.
2. This machine starts and moves automatically. Never place any part of your body near or on moving parts of this machine.
3. Always stop the spindle completely before touching the workpiece, tool or spindle.
4. Do not operate this machine unless all guards, interlocks and other safety devices are in place and functional.
5. Always clamp workpiece and cutting tool securely. Avoid excessive feeds and spindle speeds.
6. Remove ring, watches, jewelry and loose fitting clothing. Keep your hair away from moving parts of the machine.
7. Always wear safety glasses, safety shoes and hearing protection when operating this machine.
8. Service or installation of this machine must be performed by qualified personnel only, following procedures described in the Maintenance Manual. Turn off and lock out power at main electrical panel before servicing.

It is the responsibility of the user to be sure that this machine is in safe operating condition at all times and that the operator follows the safe operating procedures described in the Operator and Maintenance Manual and all signs attached to this machine. If you have any questions concerning the safe operation of this machine, contact your supervisor or local Distributor.

Please do not remove or disfigure this sign.

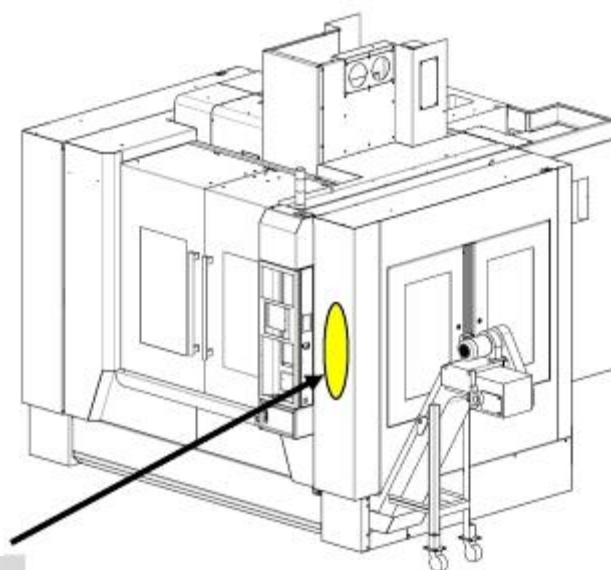

Operation Box side

Figure 1.2 LOCATION OF WARNING LABEL

	<p>! DANGER</p> <p>Hazardous voltages inside of control system. Power off when doing maintenance.</p>	<p>! WARNING</p> <p>Exported strategic high-tech commodities shall not be used for producing or developing such military weapons and missiles.</p>		<p>! DANGER</p> <p>Never open door. Only for qualified service personnel. Failure to follow will result in serious injury or death.</p>
--	--	---	---	--

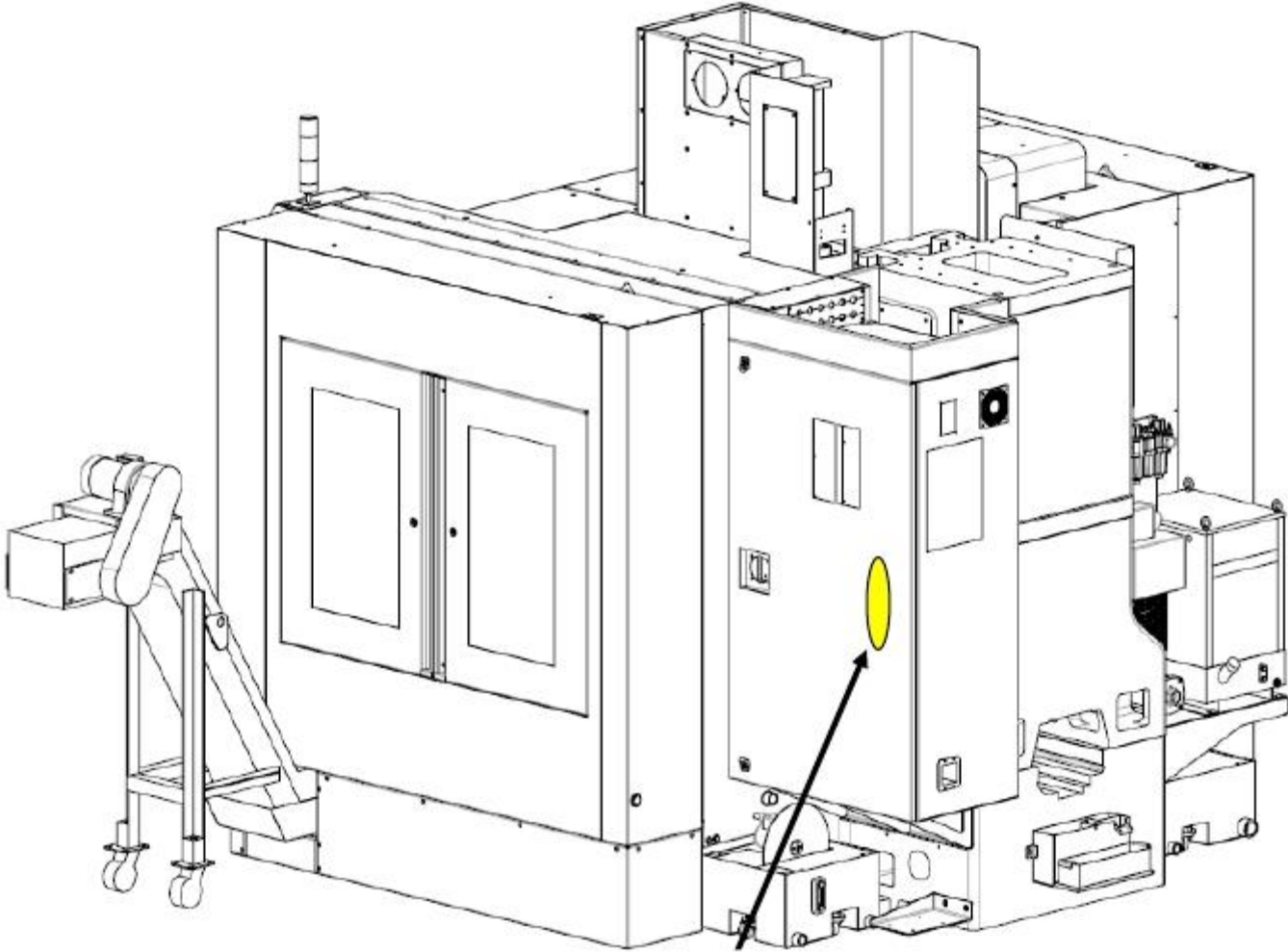

ETC Box side

Figure 1.3 LOCATION OF WARNING LABEL



Head cover

Figure 1.4 LOCATION OF WARNING LABEL

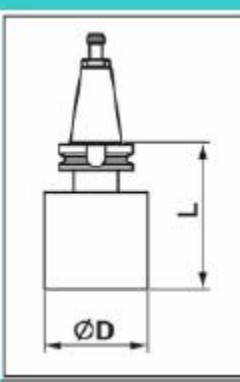
		Max.tool length
		L= 300 mm
		Max.tool diameter
		ØD= 76 mm
		(without adjacent tools)
ØD= 150 mm		
Max.tool mass		
W= 7 Kg		

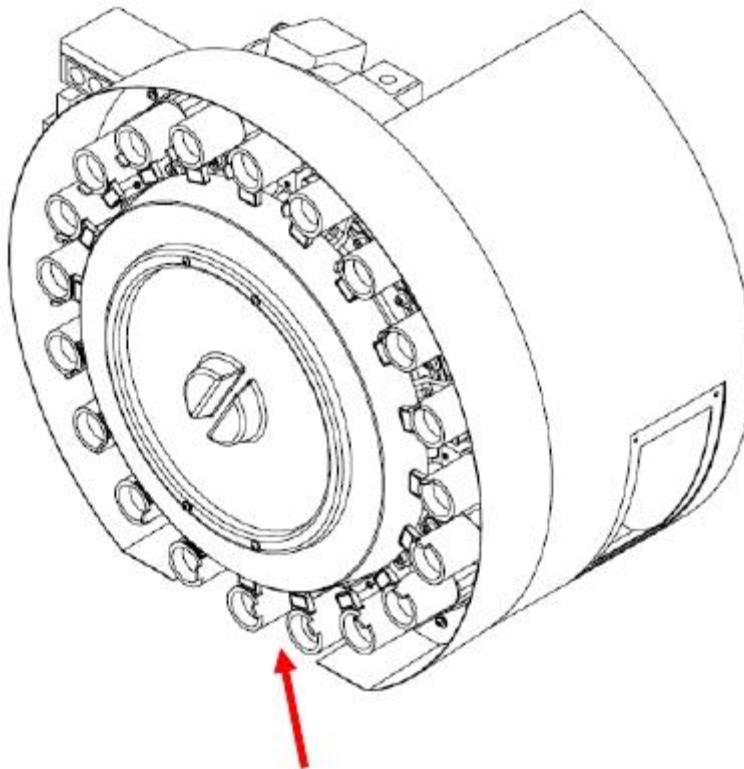

MAGAZINE FRONT COVER

Figure 1.5 LOCATION OF WARNING LABEL

1.3 Utilization of safety devices

Safety devices ( Figure 2.1) are installed on this machine in order to protect operators and Maintenance personnel .



Warning

- Confirm machine safety devices are function correctly at all times .
- If a safety devices is not functioning , or is functioning incorrectly , repair or replace immediately .
- Ensure all operators know the locations of the emergency stop buttons before operating the machine to enable immediately use un abnormal situations or following an accident .
- Never place objects on the safety guards .
- Heed the following safety precautions at all times when operating the machine with guards open :
 - Do not touch rotating or moving parts .
 - Do not touch each axis while in motion .
 - Exercise extreme care around parts that may be about to move .

1.4 Warning lists

The following tables list frequent accidents , incidents and dangerous or careless operating Conditions , and the injuries that may result .

Ensure the contents of each table are thoroughly understood prior to machine operation .

1.4.1 Inside of machining chamber

Operations : Centering , alignment , workpiece loading / unloading, changing coolant nozzle, direction, lighting replacement , chip removal, table lubrication, tool attachment /detachment .

ACCIDENT / INCIDENT	PROTENTIAL INJURIES / DAMAGE
Operator touches rotating spindle	Amputation or entanglement of hand(s) resulting in serious injury
Operator touches bladed tools	Cuts , injuries to hands
Operator lifts heavy tools	Strained back
Operator stands on center-trough conveyor or the surrounding splash guard and slips .	Bone fracture
Feed axis moves , trapping operator in machine	Bone fracture
Operator is struck by ATC Arm	Bone fracture
Operator is struck by chips and cutting fluid scattered during machine .	Damage to eyes or cuts / burns to skin
Operator is splashed by cutting fluid dripped from ceiling .	Damage to eyes
Hand(S) caught when closing S/ G door	Bone fracture
Spindle is rotated with a tool incorrectly clamped while door is open .	Injury or death
Spindle is rotated prior to cleaning of tapered section while door is open	Injury or death
Spindle is rotated with a bladed tool incorrectly mounted while door is open .	Injury or death
Unbalance tools are rotated at high speed while door is open.	Injury or death

1.4.2 Tool Magazine , Tool Magazine Door

Operations : Tool replacement and lubrication

ACCIDENT / INCIDENT	PROTENTIAL INJURIES / DAMAGE
Operator touches bladed tools	Cuts or puncture injuries to hands
Operator lifts heavy tools	Strain back
T-serch or tool change is commanded when tool is incorrectly stored in pot	Injury or death
T-search or tool change is commanded when tool blade is mounted incorrectly .	Injury or death
Operator works on oily floor	Bone facture , injury cause by falling
Operator enters tool magazine without turning OFF machine power	Injury or death
Operator insert hand into tool magazine during operation	Cuts to hands or bone fractures

1.4.3 Cutting Fluid, Chips, Cutting Fluid Supply Unit, and Chip Disposal Unit

Operations : Regular machining , cutting fluid replenishment , tank cleaning , filter replacement .

ACCIDENT / INCIDENT	PROTENTIAL INJURIES / DAMAGE
Operator inhales large quantities of cutting fluid mist .	Respirator organ damage
Insufficient cutting fluid .	Fire
Contact with chemical additives .	Skin damage .
Operator inserts hands into conveyor or tank without Turning OFF machine power	Entanglement of hands resulting in serious Injury .
Operator cleans machine without wearing protective glove .	Cuts or puncture injuries to hands
Filter is replace without prior cleaning	Cuts or puncture injuries to hands
Operator works on top of the machine when anchor bolts are used incorrectly and machine is unstable .	Bone fracture ; injury caused by falling
Contact with cutting fluid .	Skin irritation

1.4.4 Signal lamp

Operations : Signal lamp bulb replacement

ACCIDENT / INCIDENT	PROTENTIAL INJURIES /DAMAGE
Working in elevated locations .	Falling , bone facture

1.4.5 Spindle Coolant Oil

Operations : cleaning

ACCIDENT / INCIDENT	PROTENTIAL INJURIES /DAMAGE
Oil temperature exceeds flashpoint . Flashpoint of spindle coolant oil (VG32) : Approximately 20°C	Fire
Inappropriate operating methods	Fluids may damage eyes or skin or be accidentally ingested or inhaled by operator .

1.4.6 Machine Surrounding Area.

ACCIDENT / INCIDENT	PROTENTIAL INJURIES /DAMAGE
Cables and piping are exposed on the floor .	Falling

1.4.7 Electric System.

ACCIDENT / INCIDENT	PROTENTIAL INJURIES /DAMAGE
Operation without turning OFF main power switch .	Electric shock, machine malfunction, abnormal operation, or fire
Improper wiring	Machine malfunction, abnormal operation, or fire
Loosening of screws in terminal block	Machine malfunction, abnormal operation, or fire
Door of machine controller and cover of terminal box are left open .	Electric leak, machine malfunction, abnormal operation, or fire
Damage to cables on floor surrounding the machine	Electric leak, machine malfunction, abnormal operation, or fire

1.4.8 Parameters.

ACCIDENT / INCIDENT	PROTENTIAL INJURIES /DAMAGE
An NC or machine parameter not outline in this manual is change	Serious injury or death, damage to workpiece or machine .



Before performing maintenance on the servo amp, spindle amp, turn off the machine power switch and confirm that the red LED indicator(charged) for each device is extinguished .

High voltage current flows through components inside the terminal box .

High voltage current continues to flow on the primary side of the main power switch even after the switch is turned off .

Electrical current continues to flow to lamps outlets in the machine controller even after the main power switch us turned off .

Chapter 2

PREPARATIONS_FOR_INSTALLATION

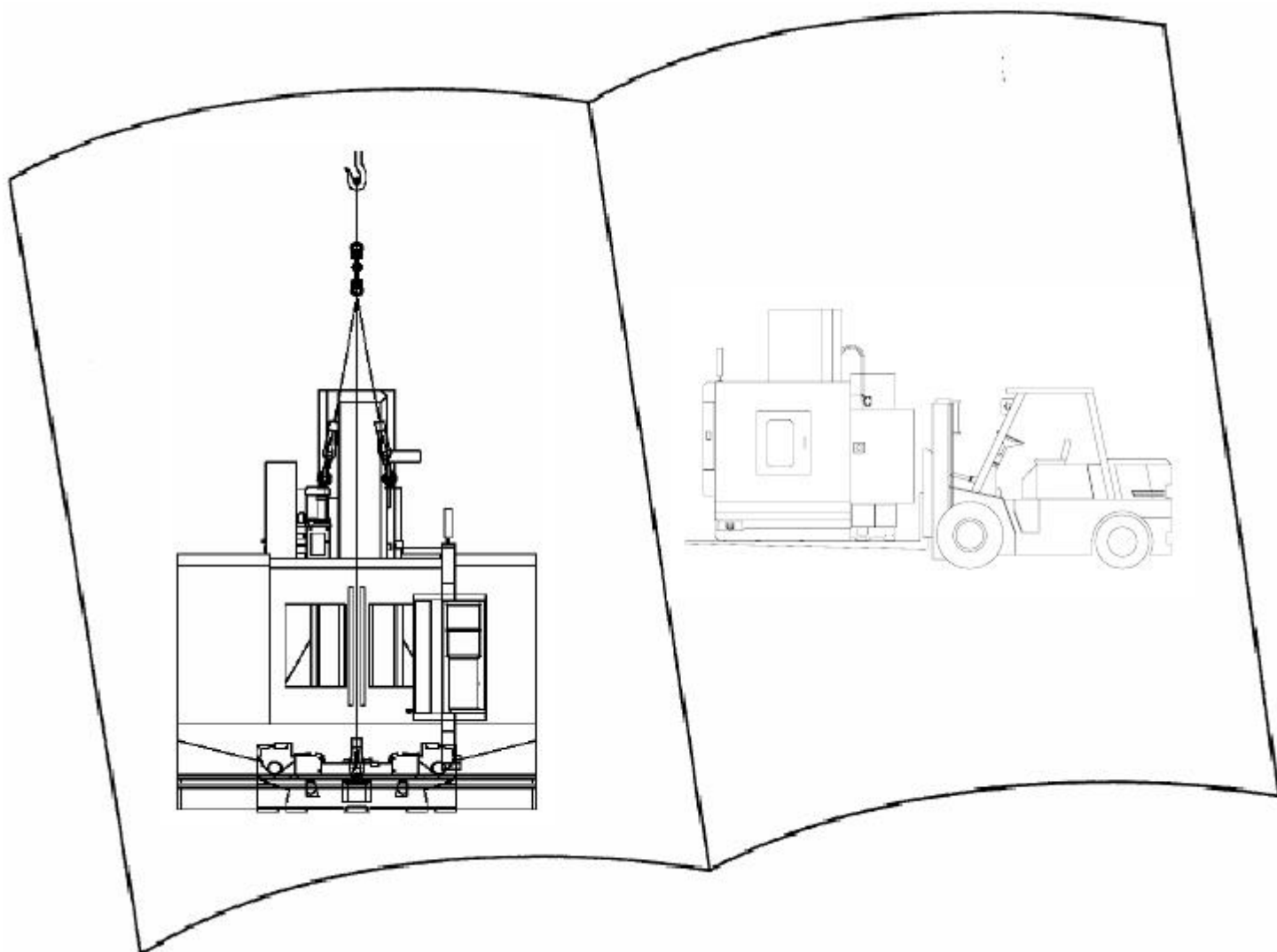

OVERVIEW

Prior to machine installation, perform the following preparations to ensure all installation conditions are satisfied :

- Preparation of set-up area .
- Preparation of transport route .
- Preparation of transportation equipment .
- Set-up conditions
- Air / power sources
- Recommended Foundations



Machine installation is to be performed by specialized personnel only .

1. PREPARATION OF SET-UP AREA

Prior to installation, confirm spacing requirements .

Maintenance area refers to the maintenance space required after installation .

Model	A	B
SV-4328 ST/SX	3100 mm	2825 mm
SV-5128 ST/SX	2745 mm	2895 mm
SV-6332 SX	3310 mm	3428 mm

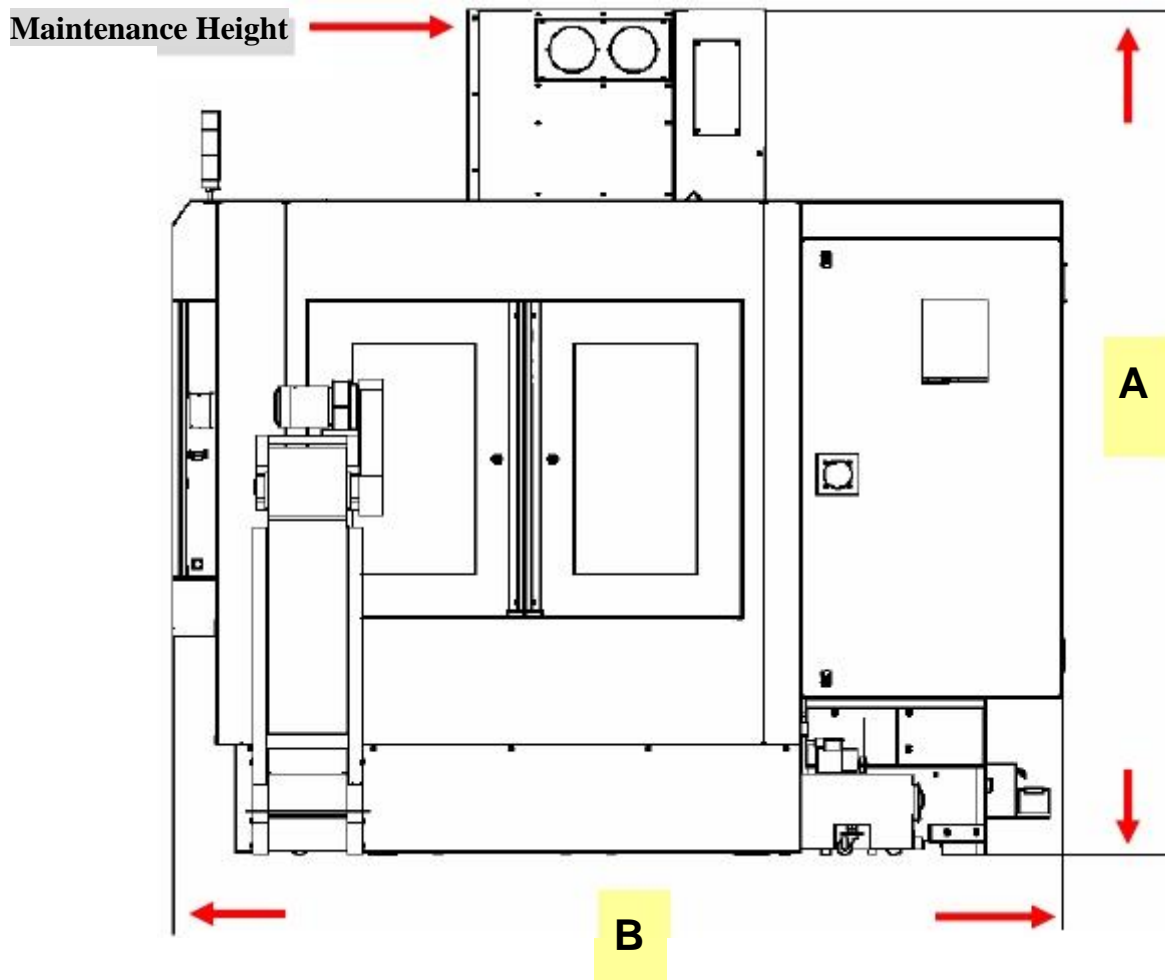

Figure 1.1 SIDE VIEW OF MACHINE

Model	A	B
SV-4328 ST/SX	3235 mm	4600 mm
SV-5128 ST/SX	3215 mm	4900 mm
SV-6332 SX	3310 mm	5800 mm

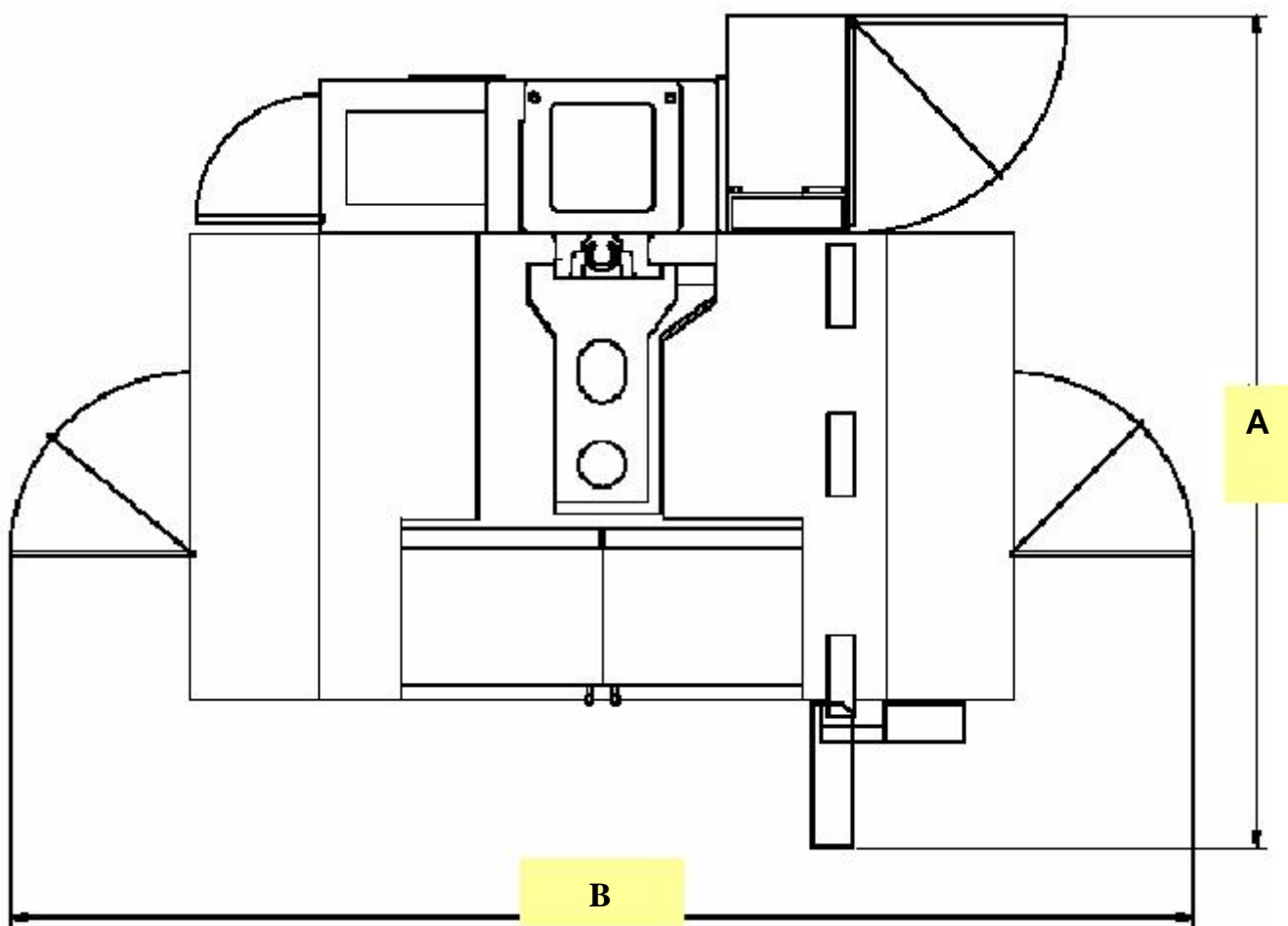

Figure 1.2 TOP VIEW OF MACHINE

Model	A	B
SV-4328 ST/SX	1650 mm	2900 mm
SV-5128 ST/SX	1650 mm	3200 mm
SV-6332 SX	1842 mm	4400 mm

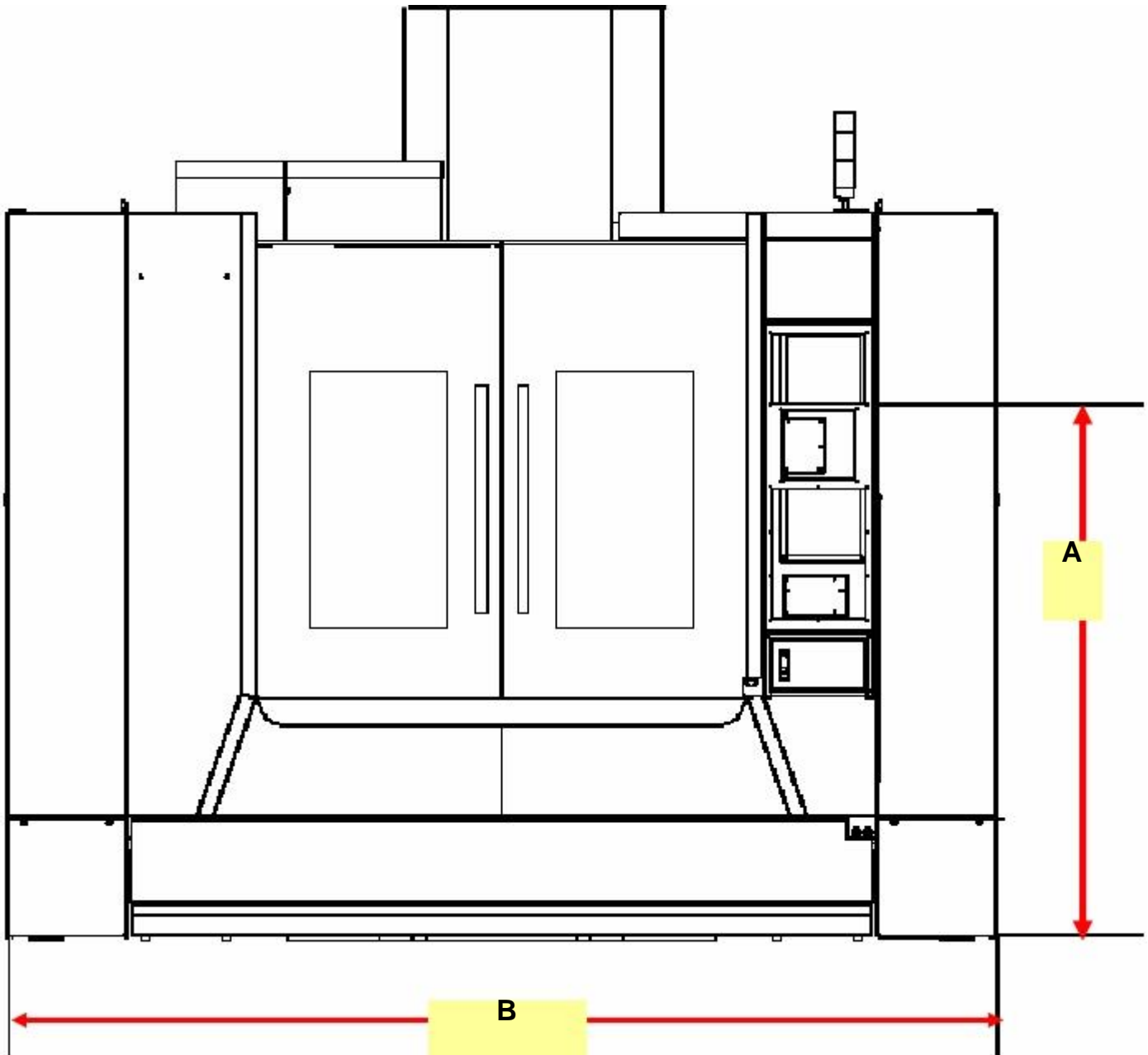

Figure 1.3 FRONT VIEW OF MACHINE

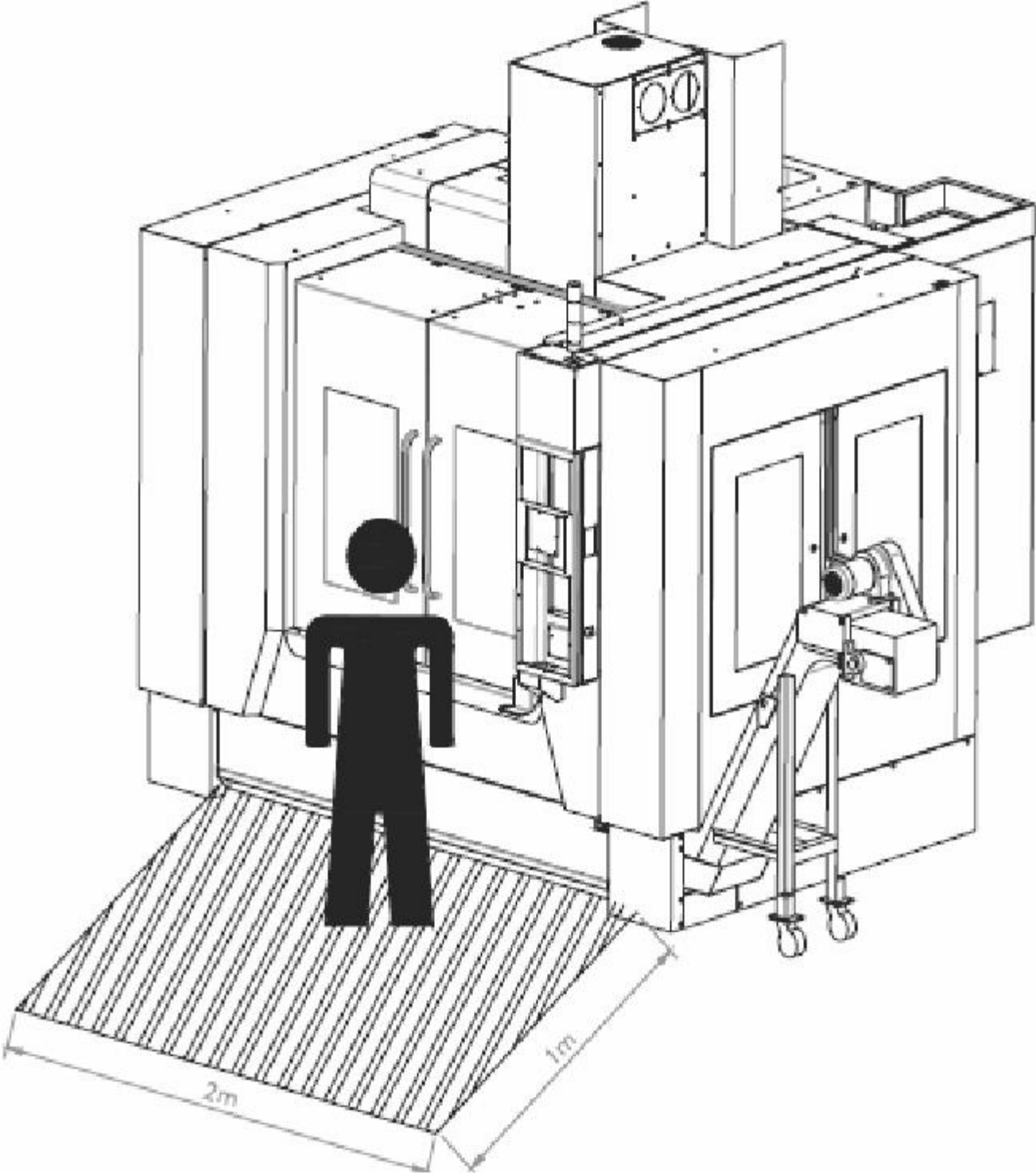



Figure 1.4 OPERATOR POSITION VIEW OF MACHINE

2. Preparation Of Transport Route

Prepare the machine transport route referring to the machine size at shipment ( Table 2.1)

Item	Type	Height	Width	Depth
Machine Body	SV4328ST/SX	3100	3200	2825
	SV5128ST/SX	2745	3200	2825
	SV6332SX	3310	4400	3428



When lifting the machine body using a crane the total height requirement necessary to Provide adequate lifting space is 500mm plus the height of the lifting equipment . ( Figure 2.1)

Figure 2.1
MACHINE BODY AT SHIPMENT



3. Preparation Of Transportation Equipment

Prior to transportation of the machine, prepare equipment capable of supporting the size and standing weight of the machine such as a crane, fork lift truck .

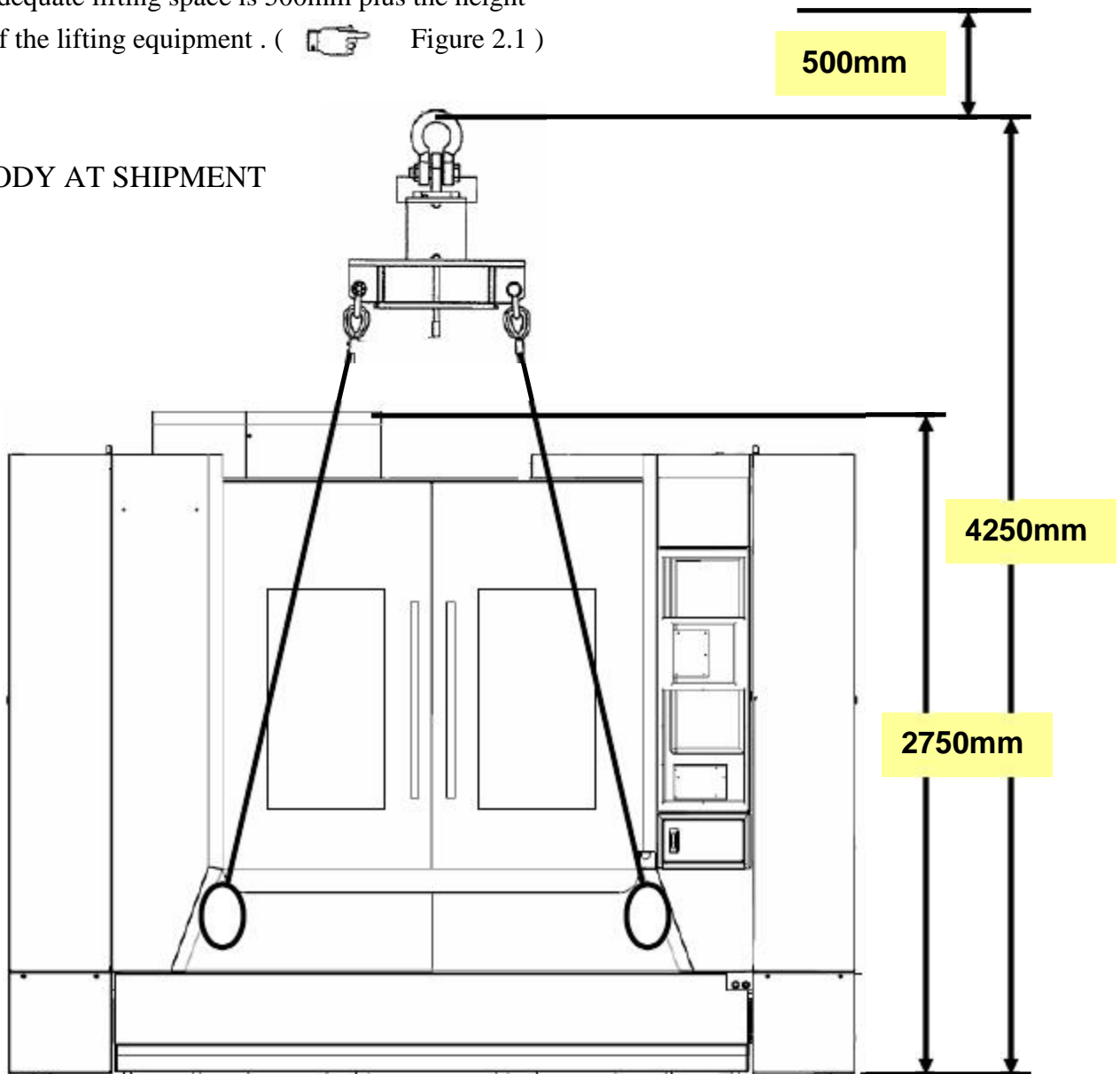
Table 3.1 MACHINE WEIGHT AT SHIPMENT

Item	Type	Weight (including lifting equipment)
Machine body	SV4328ST/SX	Approx. 7200Kg
	SV5128ST/SX	Approx. 8000Kg
	SV6332SX	Approx. 15000Kg

Handling Unpackaged Machine

Handle the Unpackaged Machine by a Forklift

1. The unpackaged machine approximately weighs 7.5 tons. The forklift used for handling the machine should have a safe load capacity greater than 9 tons so as to avoid accidents.
2. Check if there is any person or obstacle in the way while moving the machine.
Please evacuate people and remove obstacles before moving so as to avoid collision and ensure the safety of personnel and machinery.
3. Adjust forks of a forklift to a proper position before moving. Pay attention to the barycenter of the machine. Place it at the loading center of a forklift so as to avoid losing balance and causing accidents.
4. When the machine is lifted by the forks, pay attention to the height the forks go. If the barycenter is at a higher position, it may swing and lose balance and then cause accidents.
5. If the sight is hindered while moving the machine, please back the vehicle. Meanwhile, ask someone to help give directions to ensure safety. Drive the forklift as slowly as possible

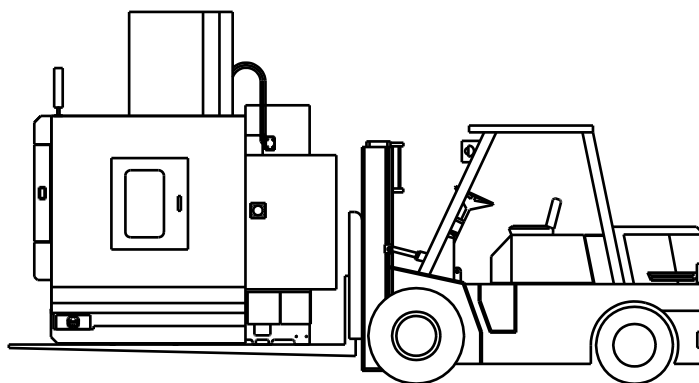

Figure 3.1 Handle the Unpackaged Machine by a Forklift

4. SET-UP CONDITIONS

Table 4.1 SET-UP CONDITIONS

Set-Up Location And Environmental Conditions
Ambient Temperature : 10 to 40 degrees (optimum 26 ± 1 degree)
Relative Humidity : 35 to 70% (no condensation)
Temperature Fluctuation : less than 1 degree / 1 hr
Well-illuminated
Free from direct sunlight
Dust-free
Available space for storing raw materials, finished workpieces and tools.
Available space for maintenance work .
Adequate space around machine to open doors completely
Required electrical power sources
A level foundation strong enough to support the weight of the machine
Appropriate distance from factory air ducting / inlets (air flow)

5. AIR / POWER SOURCE

Table 5.1 AIR / POWER SOURCE (1)

Item	Specifications	
Electrical Source	AC200/220V ± 10% & 50/60HZ ± 2%	
Maximum Power Consumption	SV4328ST/SX	30 KVA (Standard) 35 KVA (Including Options)
	SV5128ST/SX	30 KVA (Standard) 35 KVA (Including Options)
	SV6332SX	35 KVA (Standard) 40 KVA (Including Options)
Total Power Requirements	Actual :	
	SV4328ST/SX	30 * 0.7 = 21KVA (Standard)
		35 * 0.7 = 25KVA (Including Options)
	SV5128ST/SX	30 * 0.7 = 21KVA (Standard)
		35 * 0.7 = 25KVA (Including Options)
	SV6332SX	35 * 0.7 = 25KVA (Standard)
40 * 0.7 = 28KVA (Including Options)		
Air Source	0.5 to 0.8 MPa 660L / min (ANR) without scale with air blow Dew point temperature : -20 degrees or less ·Clean air is to be provided : Equivalent to ISO 1.5.1 standard as specified by ISO 8573-1 ·Max. particle diameter : 0.0001mm or less ·Dew point at max pressure : Below 7 degrees ·Max oil concentration : 0.01 mg/m ³ or less	
Air Dryer	Should be ordered or unless provided by customer	
Air Filtration Unit	5µm + 0.3µm + Moisture Remover	

Table 5.2 AIR / POWER SOURCE (2)

Power Source	Breaker Rated Current (A)	Cable Size (Ex)
Up to AC240V	60A	10mm ² V

IV : 600V PVC insulated wire

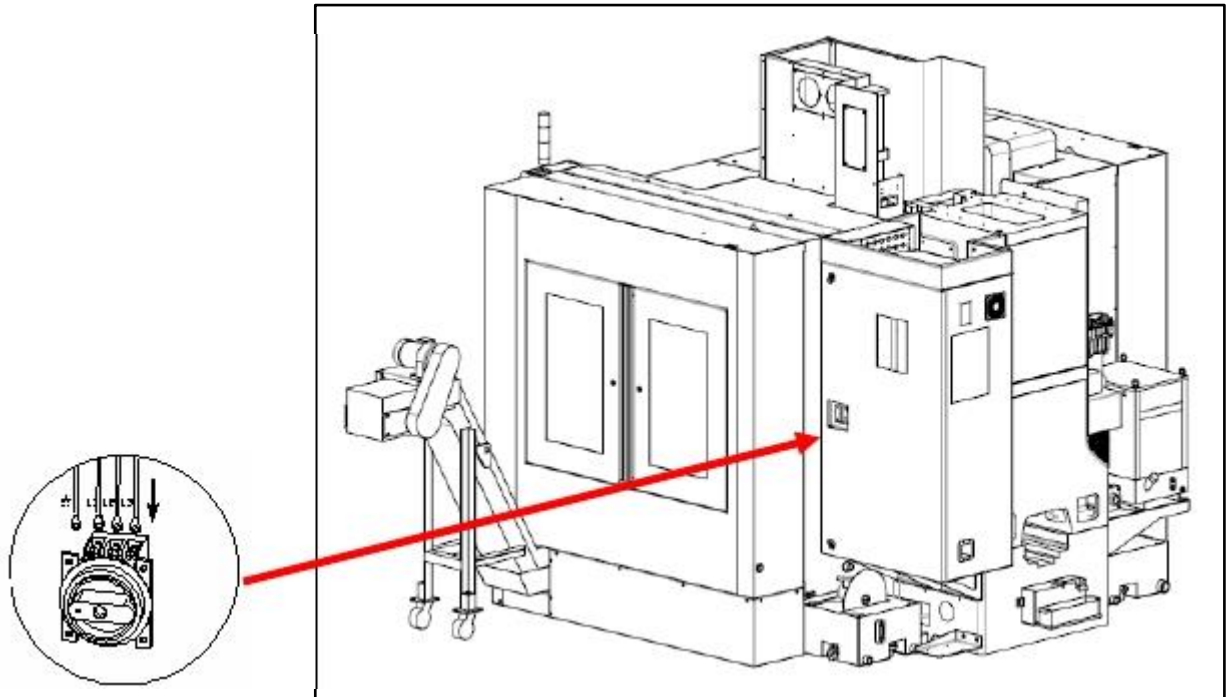

Figure 5.1 Electrical Power Source Connection

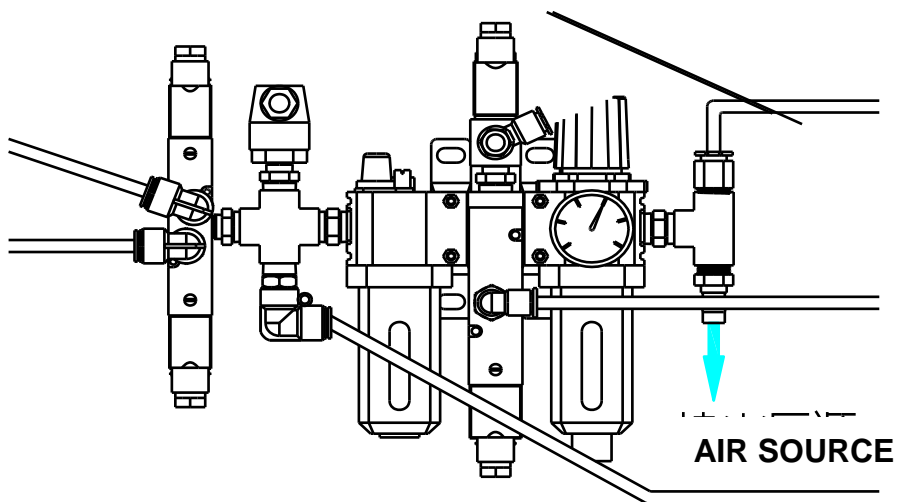

Figure 5.2 Air Source Connection

SV6332 :

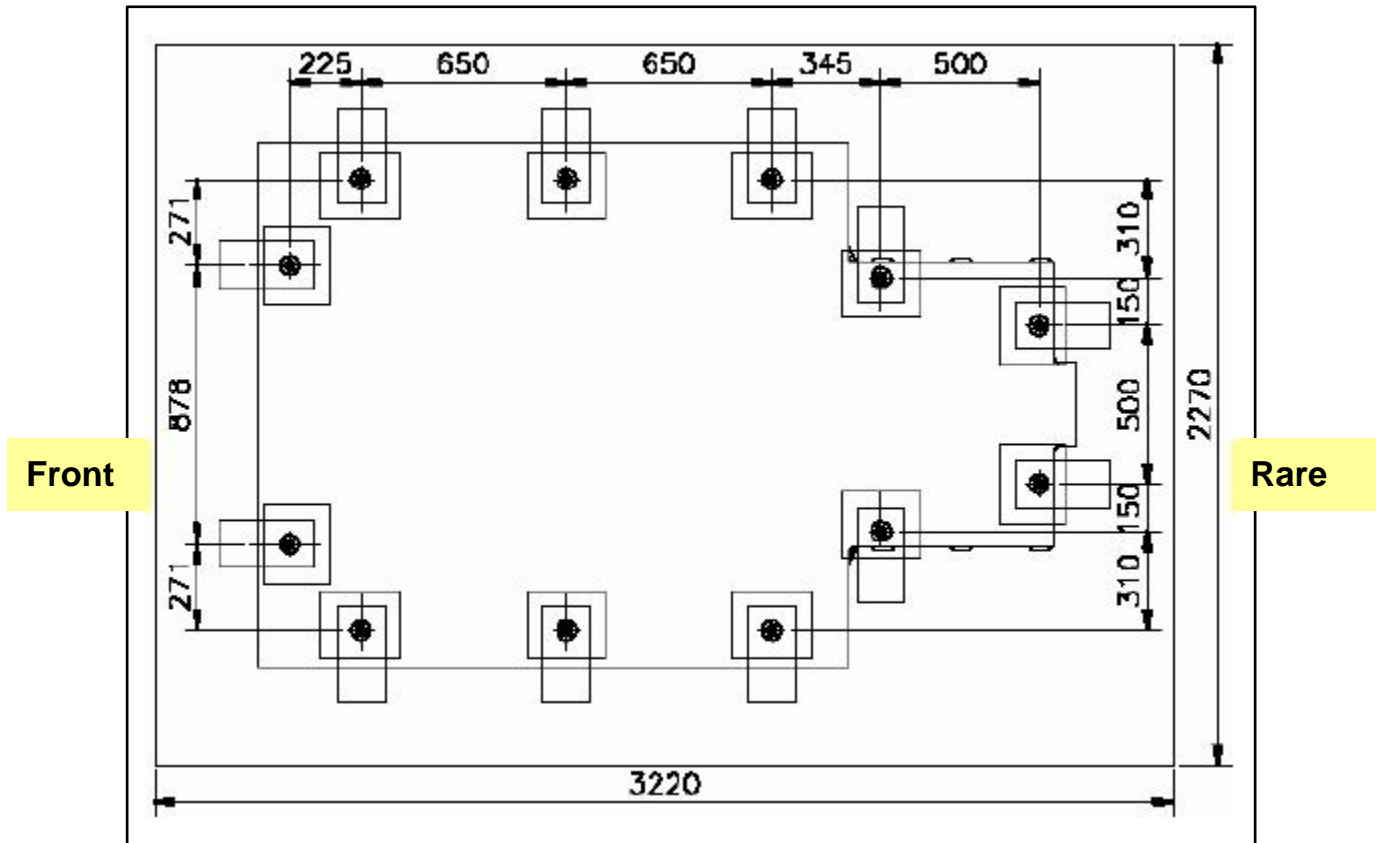

Figure 6.1.1 Foundation Drawing

NOTES :

1. Foundation preparation are generally not required if the floor thickness is 500mm or more of reinforced concrete . However, when additional machinery is in use surrounding the machine, foundation preparations are required.
2. The following data is to be used as a reference. Concrete required is FC180 standard and above.
 - For rubble, use medium or large size crushed stones.
 - Section C ensures isolation from surrounding vibration. Use small crushed stone.
 - leveling concrete thickness : 200mm



The foundation drawings on previous pages show only recommended values. Foundation requirements vary according to ground conditions. Prior to performing foundation preparations, consult a civil engineer or building contractor.

Chapter 3 OPERATION

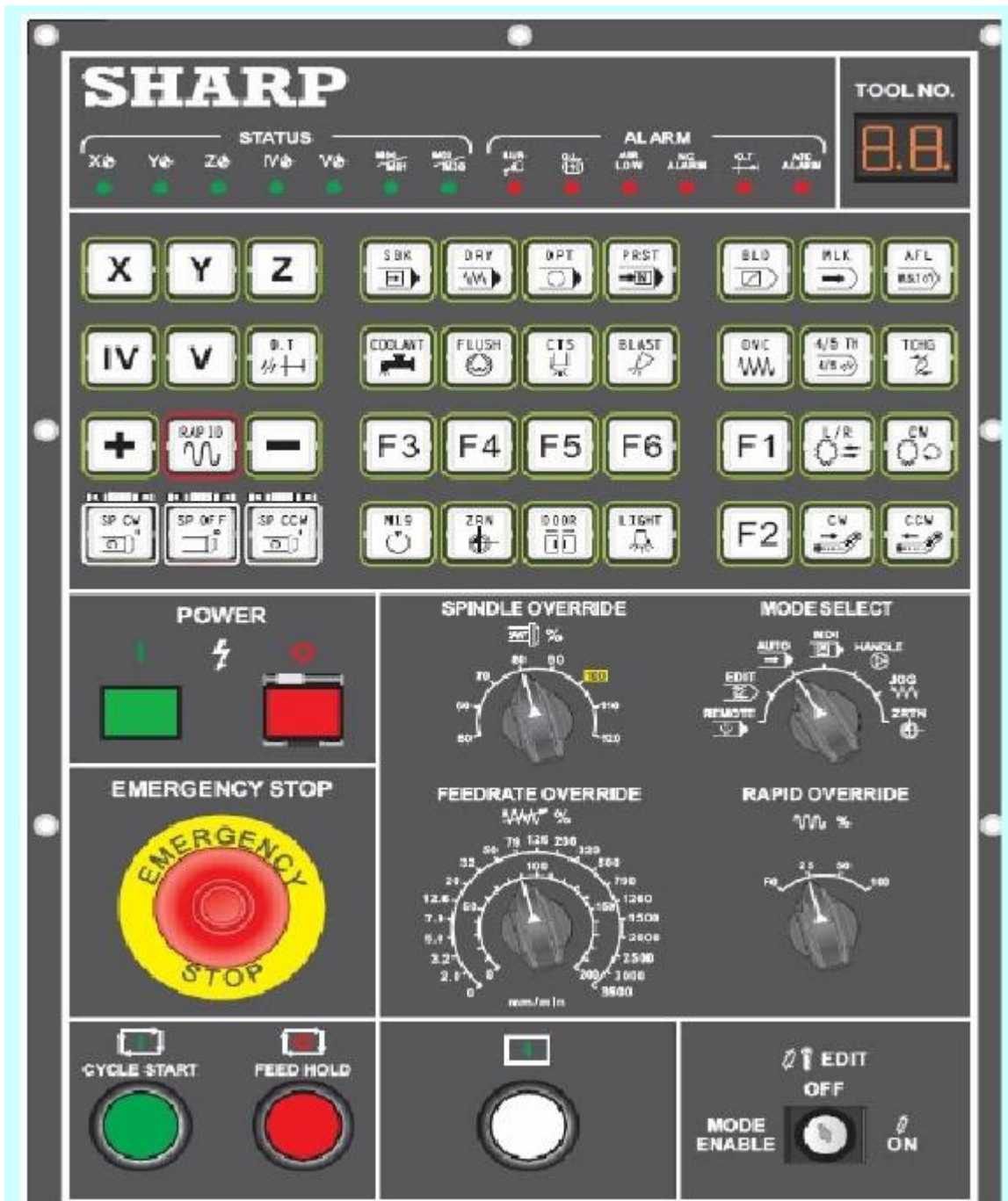

BEFORE STARING OPERATION

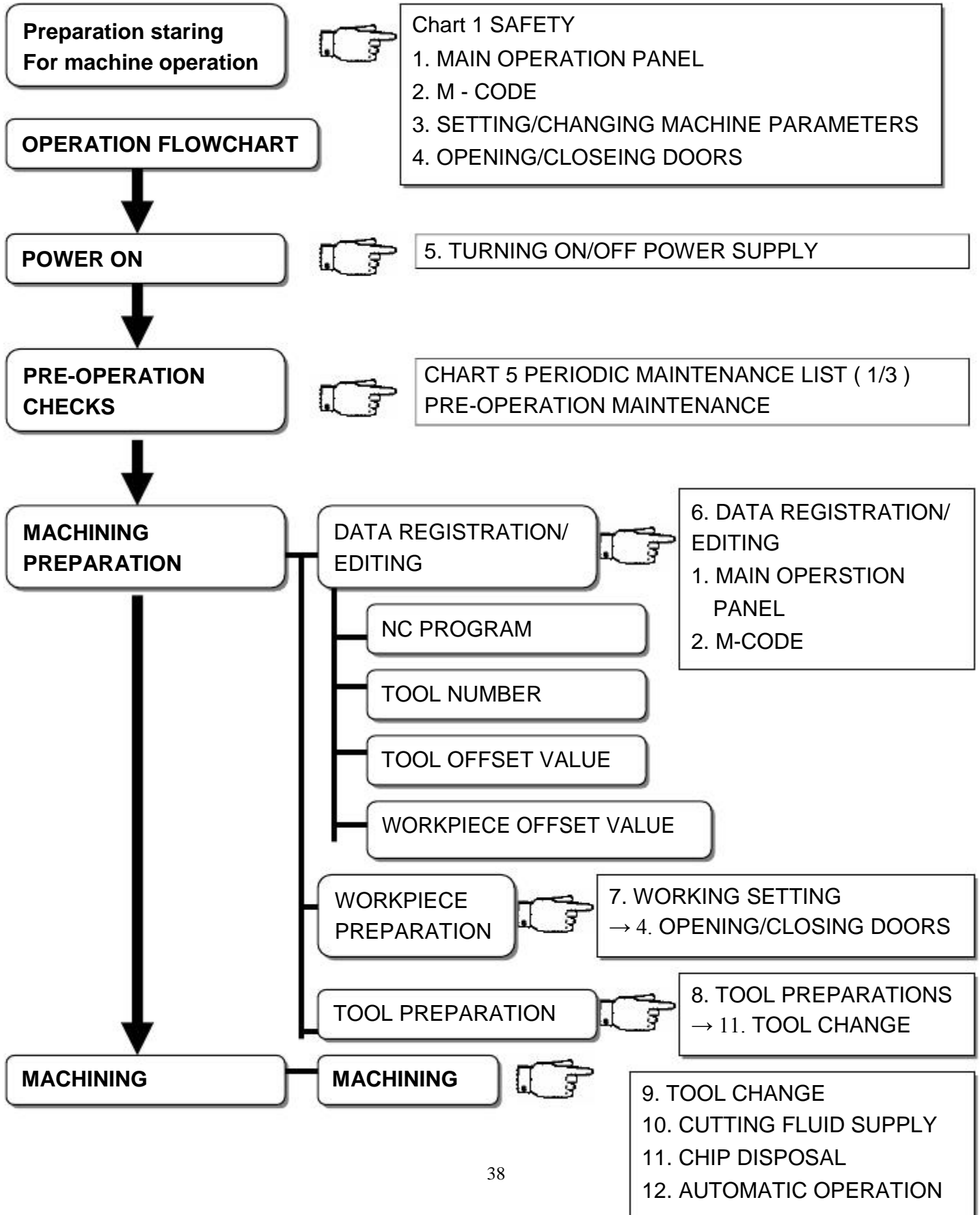

1. MAIN OPERATION PANEL

The main operation panel is used to perform the following operations;

- Manual / Automatic operation
- Turning functions on/ off and changing operating modes
- Registering and editing NC programs
- Inputting tool offset values and work coordinate system settings
- Changing parameters
- Display alarm screens and maintenance operations

1.1 MAIN OPERATION PANEL FUNCTIONS

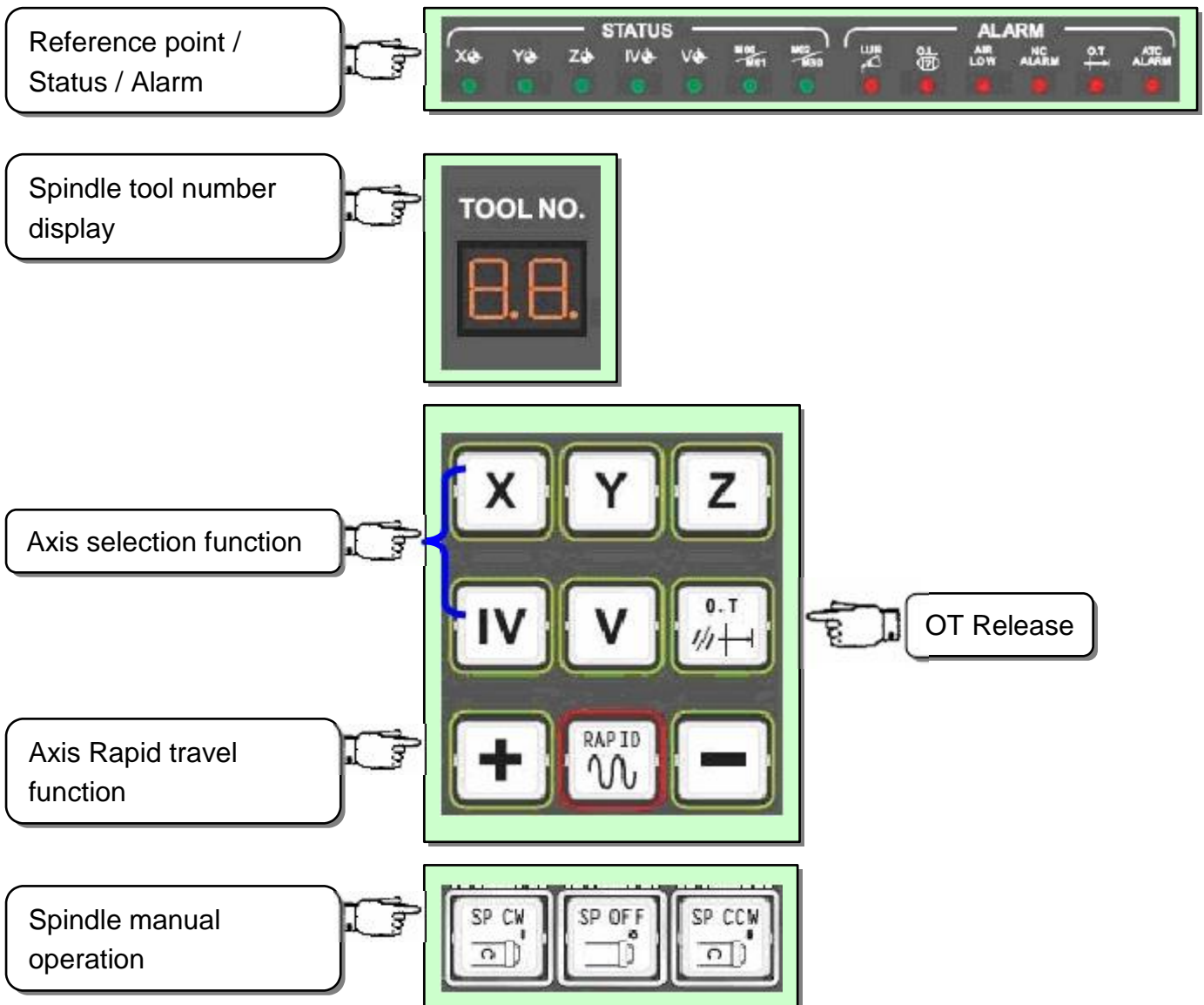

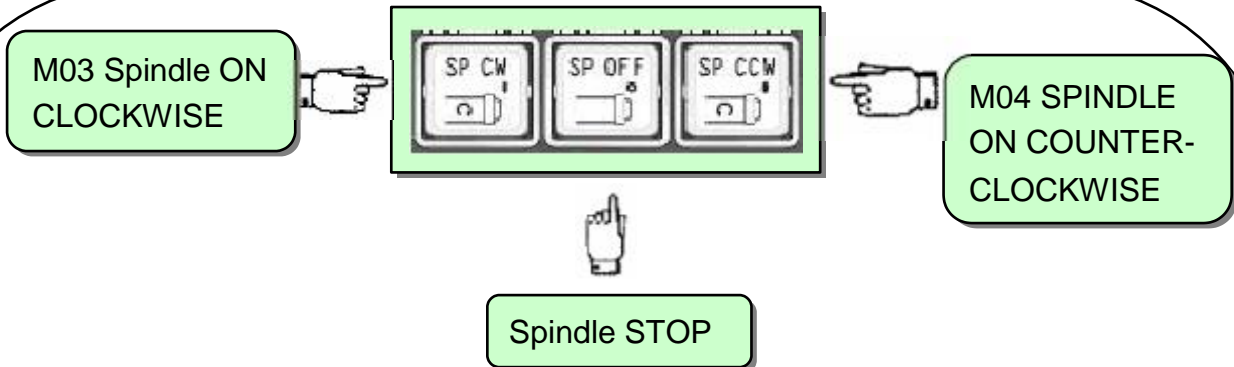

TO START OR STOP THE SPINDLE IN RAPID, JOG OR HANDLE MANUAL OPERATION MODE, THESE SWITCHES ARE USED.

A. SET THE MODE SELECT SWITCH TO MDI POSITION AND SET SPINDLE SPEED IN MDI OPERATION AS FOLLOW..

IN FANUC 0i CONTROL

KEYIN **SXXXX** THEN "INPUT"

PUSH (2) CYCLE START TO EXECUTE

IN FANUC 18iMC CONTROL

KEYIN **SXXXX;**

PUSH (2) CYCLE START TO EXECUTE

B. SELECT THE DESIRED MODE AMONG RAPID, JOG AND HANDLE MODES BY THE MODE SELECT SWITCH

C. PRESS THE PUSH BUTTON SPINDLE CW OR CCW ,THE SPINDLE WILL START RUNNING AT THE SET SPEED AT STEP A.

D. THE SPINDLE STOPS WHEN THE PUSH BUTTON SPINDLE OFF IS PRESSED.

E. TO START AGAIN, PRESS THE PUSH BUTTON SPINDLE ON THE SPINDLE STARTS RUNNING AT THE SET SPEED AT STEP A. AGAIN.

TO CHANGE SPINDLE SPEED REPEAT STEPS A. – E. AFTER SETTING PUSH THE CYCLE START BUTTON THE SPINDLE WILL RUN AT THE NEWLY SET SPEED. NOTE : DOOR MUST CLOSED TO MATCH COMMAND'S SPEED.

F. WHEN DOOR OPEN NEED TO RUN SPINDLE KEEP PRESS PERMISSIVE BUTTON PRESS SP CW OR SP CCW FOR JOG RELEASE TO STOP SPINDLE.



RAPID

IN JOG MODE, PUSH THIS BUTTON TOGETHER WITH X+ X- Y+ Y- Z+ Z- IV+ IV- TO MOVE THE AXIS RAPIDLY.

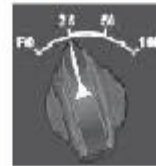

SET THE RAPID SPEED BY RAPID OVERRIDE SELECT SWITCH

PROGRAMMING FUNCTION
BUTTON



CUTTING FUNCTION
BUTTON



OPTION FUNCTION BUTTON



SINGLE BLOCK

THE SWITCH IS APPLIED TO EXECUTE TAPE PROGRAM OR MEMORY PROGRAM STEP BY STEP WHEN THE PUSH BUTTON IS SET TO ON AND THE PUSH BUTTON CYCLE START (2) IS PRESSED. THE MACHINE EXECUTES ONE BLOCK OF THE PROGRAM AND STOPS. WHEN THE PUSH BUTTON SINGLE BLOCK IS PRESSED DURING MEM MODE OPERATION, THE MACHINE STOPS AFTER EXECUTED OF THE CURRENT BLOCK.



DRY RUN

WHEN THE SWITCH IS SET AT ON, FEED COMMAND (F CODE) IN THE PROGRAM IS IGNORED DURING MEM, MDI OPERATION MODE AND THE FEED SPEED SELECTED BY THE SELECT SWITCH JOG FEEDRATE (39) BECOMES EFFECTIVE. THE RAPID TRAVERSE SPEED CAN BE ALSO CHANGED BY THE SWITCH DRY RUN.

**OPTIONAL STOP**

BY SETTING THIS SWITCH, THE OPTIONAL STOP FUNCTION OF M 01 IS IGNORED OR NOT IGNORED DURING MEM OPERATION MODE.

WHEN THE SWITCH IS SET AT ON, THE BLOCK WITH M 01 IS EXECUTED AND THE OPERATION STOPS AFTER THE EXECUTION OF THE BLOCK.



PROGRAM RESTART : The case of cutting tool breakage, or after the holidays , this function enables restart the program .

1) Press this button on, display the program to be restarted inputting either the sequence number or the block number.

**COOLANT ON / OFF**

PUSH TO START COOLANT, PUSH AGAIN TO STOP.

PRIORITY IS GIVEN TO THE SETTING OF THE SWITCHES OVER M FUNCTION SUCH AS M08 (COOLANT ON) AND M09 (COOLANT OFF).

**CHIP FLASH ON/OFF**

PUSH TO START CHIP FLASH, PUSH AGAIN TO STOP.

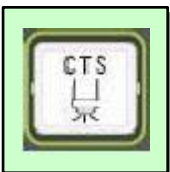
**COOLANT THROUGH SPINDLE ON/OFF**

PUSH TO START COOLANT THROUGH SPINDLE, PUSH AGAIN TO STOP.

**Air blast button:**

Press this button to start air blast, press it again to stop it



SPARE FUNCTION FOR OPTION



M19 SPINDLE ORIENTATION

PUSH THIS BUTTON TO ORIENTATE SPINDLE (M19)



AUTO ZERO RETURN

THE SWITCH IS USED TO RETURN THE SPINDLE HEAD (Z), SADDLE (Y) AND TABLE (X) TO THE REFERENCE POINT (COORDINATE ZERO).

THE OPERATION IS AS FOLLOWS:

SET THE MODE SWITCH  TO ZRTN, PUSH THIS BUTTON.

THE TRAVEL SPEED WILL REFER TO  RAPID TRAVERSE SWITCH

NOTICE: IF START POSITION FOR REFERENCE POINT RETURN IS LOCATED WITHIN 50mm (2 inch) FROM THE REFERENCE POINT (DECELERATION RANGE) THE AXIS WILL GOES REVERSE DIRECTION UNTIL PROPER DISTANCE.



WORK LAMP ON/OFF

PUSH TO LIGHT THE WORK LAMP, PUSH AGAIN TO TURN OFF.

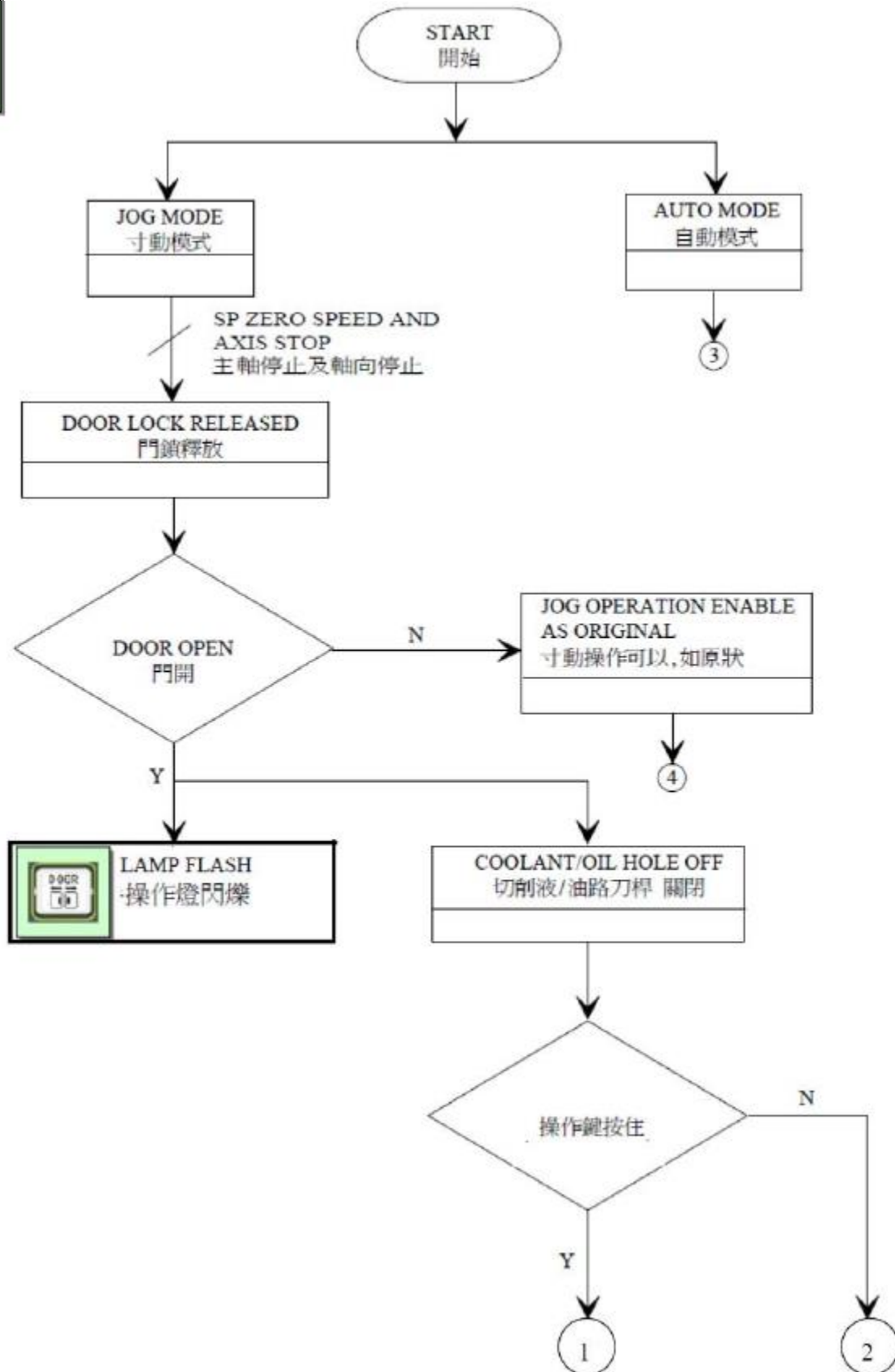

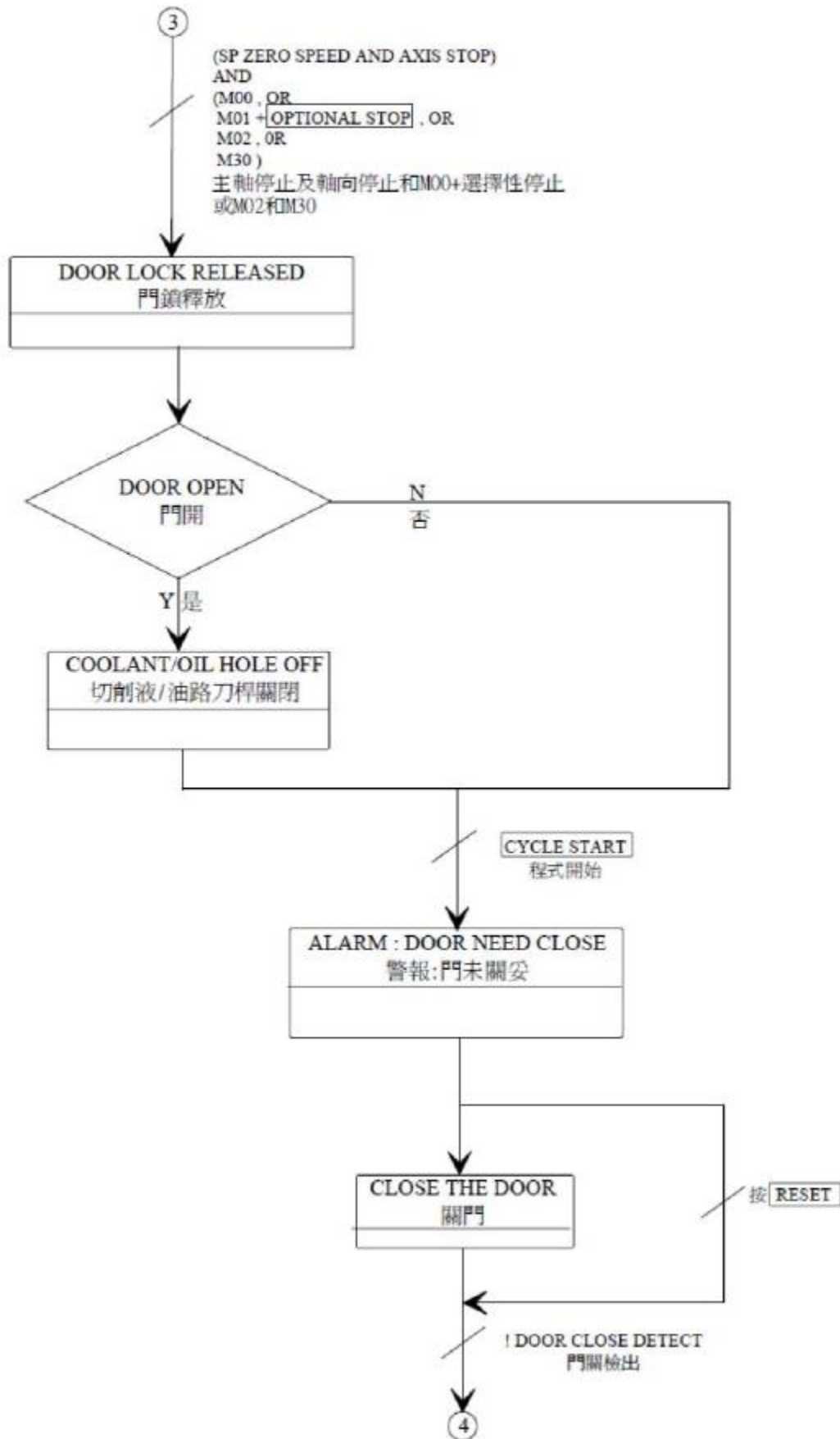

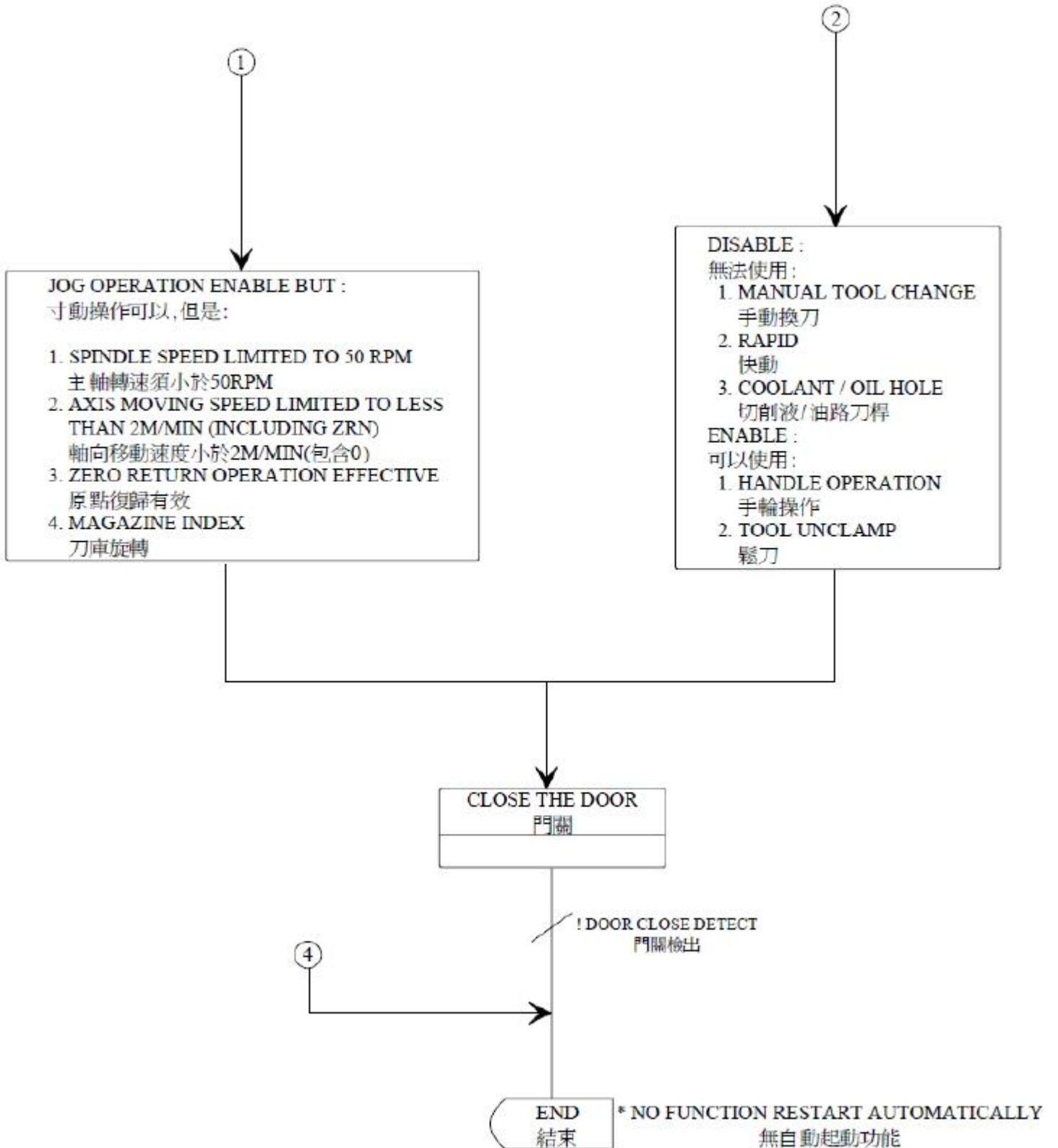

PROGRAMMING FUNCTION BUTTON DESCRIPTION

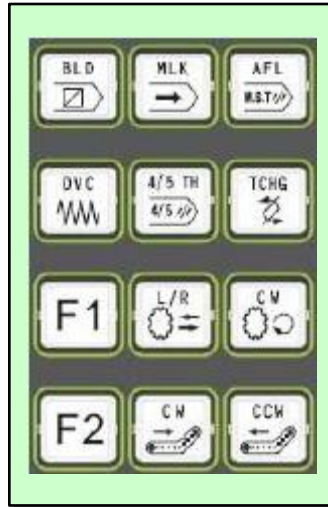

OPTIONAL BLOCK SKIP

BY SETTING THIS SWITCH, THE BLOCK HAVING "/" (SLASH) AT ITS HEAD IS IGNORED OR NOT IGNORED. WHEN THE SWITCH IS AT ON, THE BLOCK HAVING "/" AT ITS HEAD IS IGNORED.

THE SWITCH IS NOT EFFECTIVE FOR THE BLOCK IN EXECUTION AND THE BLOCK READ IN THE BUFFER, AND BECOMES EFFECTIVE FROM THE NEWLY READ BLOCK.



MACHINE LOCK

TO LOCK THE AXIS MOVEMENT DURING EXECUTE PROGRAM.

IN AUTO OR MDI OPERATION MODE, THE PROGRAM CAN BE SIMULATED, THAT IS, THE MACHINE DOES NOT ACTUALLY WORK, BUT THE DISPLAY APPEARS AS IF THE MACHINE ACTUALLY DOES.

NOTICE: M,S,T CODE STILL EXECUTE. (SPINDLE ROTATION, TOOL CHANGE STILL EXECUTE) TO

CANCEL PUSH  **M,S,T, CODE LOCK.**



M.S.T. CODE LOCK

TO CANCEL THE EXECUTION OF M, S, T, CODE IN THE PROGRAM.

NOTICE: AXIS MOVEMENT (G CODE) STILL EXECUTE, TO CANCEL, PUSH



MACHINE LOCK.



OVERRIDE CANCEL

PUSH TO RESET THE FEEDRATE TO 100%, AND IGNORE THE SETTING FROM OVERRIDE SELECT SWITCH.



NOTICE: PUSH THIS BUTTON MAY CAUSE THE SUDDEN CHANGE OF THE CUTTING FEED.



4TH & 5TH-axis On/off extraction:

- When you need to use 4TH & 5TH-axis. (Servo ready)
Ignore 4TH & 5TH-axis button is off. (Light is off)
- When you want to off the 4TH & 5TH-axis. (Servo not ready)
Ignore 4TH & 5TH-axis button is on. (Light is on)
- When you push this button, you need to restart the main power.



TOOL CHANGE

PUSH THIS BUTTON TO EXECUTE TOOL CHANGE (OPTION)

Z AXIS MUST IN TOOL CHANGE POSITION.



SPARE FUNCTION FOR OPTION



L/R button for tool magazine:

This function is not available in this machine.

**TOOL MAGAZINE TURN CLOCKWISE**

PUSH THIS BUTTOM TO ROTATE TOOL MAGAZINE CLOCKWISE, RELEASE TO STOP
(IN MANUAL MODE)

**CHIP CONVEYOR ON / OFF (JOG)**

PUSH THIS BUTTON TO START THE CHIP CONVEYOR
PUSH AGAIN TO STOP

**CHIP CONVEYOR REVERSE ON / OFF**

PUSH THIS BUTTOM TO REVERSE THE CHIP CONVEYOR
RELEASE TO STOP IT

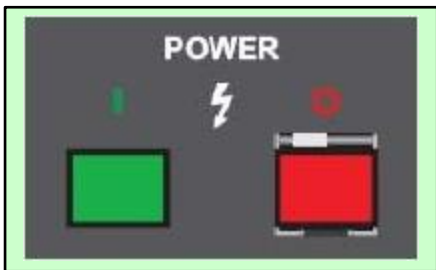
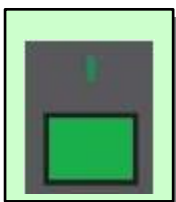
**TURNING ON/OFF POWER SUPPLY****POWER ON :**

- 1) Turning on the main power switch
- 2) Press the [CONTROL POWER ON] button

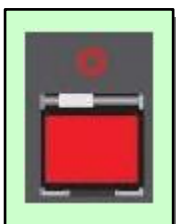
**POWER OFF :**

- 1) Press the [CONTROL POWER OFF] button
- 2) Turning off the main power switch
- 3) Emergency stop should be pressed before pressing this button).

ROTATION SELECT SWITCH DESCRIPTION



OVERRIDE SELECT SWITCH (%)

JOG FEEDRATE SELECT SWITCH (mm / min)

A. THE SELECT SWITCH PERMITS OVERRIDING THE FEED SPEED SPECIFIED BY F CODE IN AUTO OR MDI MODE OPERATION WITHIN A RANGE FROM 0 TO 200% WITH INCREMENT OF 10%.

HOWEVER, THE OVERRIDE SELECTION REMAINS INEFFECTIVE WHEN SWITCH LOCATED OVER THE OVERRIDE SELECT SWITCH IS SET AT CANCEL POSITION. THE OVERRIDE SELECT SWITCH DOES NOT EFFECT THE TAPPING FEED SPEED IN TAPPING CYCLE (G84).

B. THE FEED SPEED CAN BE PRESET BY THIS SELECT SWITCH IN AUTO OR MDI

MODE WHEN THE SWITCH DRY RUN  IS SET AT ON.

THE SPEED IS SELECTABLE WITHIN A RANGE FROM

0 TO 3.500 mm / min



SPINDLE SPEED OVERRIDE SELECT SWITCH

THIS SWITCH CAN OVERRIDDEN THE SPINDLE SPEED FROM 50 % TO 120 % , 10 % PER STEP.

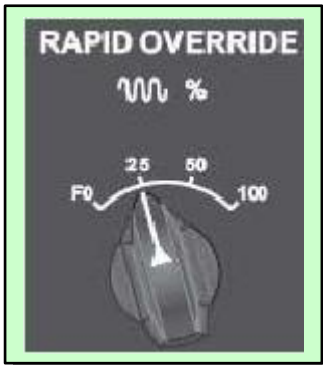

RAPID OVERRIDE SELECT SWITCH

RAPID SPEED CAN BE OVERRIDDEN BY 100%, 50% 25% F0.

WHEN THE RAPID TRAVERSE SPEED IS AT 20 m / min, AND OVERRIDDEN BY 50%, FOR EXAMPLE, THE SPEED IS REDUCED TO 10 M / min.

F0 IS SET TO 100 mm / min. THE OVERRIDE FUNCTION IS APPLICABLE TO THE FOLLOWING RAPID TRAVERSE.

- A.RAPID TRAVERSE IN GOO.
- B.RAPID TRAVERSE DURING EXECUTION OF CANNED CYCLE.
- C.RAPID TRAVERSE IN G27,28,29.
- D.MANUAL RAPID TRAVERSE IN RAPID MODE OPERATION.



MODE SELECT SWITCH

USE THIS SWITCH TO CHANGE OPERATION MODE.

(CE) BEFORE CHANGE MODE, TURN THE KEY SWITCH

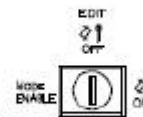











TO "MODE ENABLE", TO RELEASE THE CHANGE MODE PROTECTION.

AFTER MODE CHANGE, TURN THE KEY BACK TO OFF POSITION.

DESCRIPTION OF MODE SELECT SWITCH

<p>REMOTE</p>	<p>DNC (REMOTE) MODE</p> <p>USE THIS MODE TO RUN THE PROGRAM (MACHINING) FROM YOUR CONNECTED PERSONAL COMPUTER, AND THE OPERATION METHOD DEPENDS ON THE DNC SOFTWARE IN YOUR COMPUTER .</p>
<p>EDIT</p>	<p>EDIT MODE</p> <p>THIS MODE IS SELECTED TO STORE PROGRAM IN THE MEMORY AND TO EDIT THE PROGRAM STORED IN THE MEMORY.</p>
<p>AUTO</p>	<p>AUTO (MEMORY) MODE</p> <p>THIS MODE IS SELECTED TO EXECUTE THE PROGRAM STORED IN THE MEMORY, OR TO SEARCH THE SEQUENCE NO. OF PROGRAM STORED IN THE MEMORY.</p>

 MDI	<p>MDI MODE</p> <p>THIS MODE IS SELECTED WHEN DATA IS MANUALLY ENTERED (KEY IN).</p>
 HANDLE	<p>HANDLE MODE</p> <p>THIS MODE IS SELECTED WHEN USING PULSE GENERATOR HANDWHEEL</p>  TO MOVE AXIS MANUALLY
<p>JOG </p>	<p>JOG MODE</p> <p>THIS MODE IS SELECTING TO MANUALLY MOVE COORDINATE IN THE AXIS SELECTED BY THE AXIS SELECT BUTTOM X+ X- Y+ Y- Z+ Z- A+ A- FOR JOG OPERATION.</p>
<p>ZRTN</p>	<p>ZERO RETURN MODE</p> <p>SELECT THIS MODE THEN PUSHING</p> <p>+X  TO MOVE X TO ZERO POINT</p> <p>+Y  TO MOVE Y TO ZERO POINT</p> <p>+Z  TO MOVE Z TO ZERO POINT</p> <p>+IV  TO MOVE IV TO ZERO POINT</p> <p>YOU CAN PUSH 2 OR 3 AXIS TOGETHER</p> <p>OR IN THIS MODE PUSH AUTO ZERO RETURN BUTTON  TO MOVE THREE AXIS TOGRTHER TO ZERO POINT.</p> <p>THE TRAVEL SPEED WILL REFER TO  RAPID TRAVERSE SWITCH</p>

**EMERGENCY STOP**

THE PUSH BUTTON IS USED IMMEDIATELY STOP THE MACHINE OPERATION IN CASE OF EMERGENCY. AT THE SAME TIME AS THE PUSH BUTTON IS PRESSED, THE SERVO SYSTEM OF THE MACHINE IS SHUT OFF THE POWER SOURCE AND THE NC EQUIPMENT IS RESET.

TO START THE MACHINE AGAIN AFTER THE EMERGENCY STOP, PROCEED AS FOLLOWS:

- A. ELIMINATE THE CAUSE OF EMERGENCY STOP AND SET UP THE MACHINE TO BE READY FOR OPERATION.
- B. WHEN THE EMERGENCY STOP PUSH BUTTON IS PRESSED, THE PUSH BUTTON IS LOCKED.
TO RELEASE THE PUSH BUTTON FROM LOCKING, ROTATE OR PULL IT .
- C. PRESS RESET BUTTON ON THE NC OPERATION PANEL.
- D. AFTER RESETTING FROM THE EMERGENCY STOP, BE SURE TO PERFORM ZERO RETURN OF ALL AXIS IN MANUAL OPERATION.

**PROGRAM PROTECT AND MODE ENABLE**

THERE ARE TWO FUNCTIONS ON THIS PROTECT KEY SWITCH

A · PROGRAM EDIT PROTECT

FOR PROTECT THE PROGRAM STORED IN THE MEMORY FROM ERRONEOUS OPERATION. THE SWITCH SHOULD NORMALLY SET AT OFF POSITION.

WHEN THE SWITCH IS SET AT ON, THE FOLLOWING FUNCTIONS ARE AVAILABLE.

- STORING AND EDITION OF PROGRAM.
- RESETTING OF COORDINATE SYSTEM

WHEN THE SWITCH ZERO RETURN IS PRESSED WITH X, Y OR Z AXIS SPECIFIED, THE ABSOLUTE VALUE OF THE CORRESPONDING AXIS TURN TO "0".

SETTING OF TOOL POSITION OFFSET, TOOL DIAMETER OFFSET AND TOOL SETTING UP.

B · MODE ENABLE

WHEN CHANGE MODE, SELECT SW (42) MUST ON THEN OFF TO CONFIRM MODE CHANGE.

**PROGRAM START /
FEED HOLD DESCRIPTION****CYCLE START**

THIS IS A LIGHTING PUSH BUTTON, AND USED TO START OPERATION IN (41) AUTO OR MDI OPERATION MODE. WHEN THE PUSH BUTTON IS PRESSED, THE LAMP IN THE PUSH BUTTON LIGHTS.

THE PUSH BUTTON IS PRESSED TO RESTART OPERATION AFTER OPERATION STOP WHEN THE PUSH BUTTON FEED HOLD (37) OR SINGLE BLOCK (9) IS OPERATED, OR WHEN OPERATION MODE IS CHANGED.

**FEED HOLD**

THIS PUSH BUTTON IS USED TO STOP OPERATION IN AUTO OR MDI OPERATION MODE. WHEN THE PUSH BUTTON IS PRESSED, THE LAMP IN THE PUSH BUTTON CYCLE START GOES OUT. WHEN THE PUSH BUTTON IS PRESSED IN THE COURSE OF COORDINATE DISPLACEMENT, THE MOVEMENT IS DECELERATED AND STOPS WHILE THE OPERATION DOES NOT IMMEDIATELY STOP.

WHEN THE PUSH BUTTON IS DEPRESSED DURING EXECUTION OF M, S OT T FUNCTION, BUT STOPS AFTER THE COMPLETION OF THE FUNCTION. THE PUSH BUTTON IS NOT EFFECTIVE DURING TAPPING CYCLE (G84), (G74) OR DWELL (G04). HOWEVER OPERATION IS STOPPED DURING EXECUTION OF CANNED CYCLE BY OPERATING THE PUSH BUTTON SINGLE BLOCK, THE LAMP IN THE PUSH BUTTON LIGHTS INDICATING THE EXECUTION PUSH BUTTON LIGHTS INDICATING THE EXECUTION OF THE CANNED CYCLE.



Ready and program protection key button

After press "power control on" button, press this button to make machine ready to be operated.

HANDWHEEL DESCRIPTION

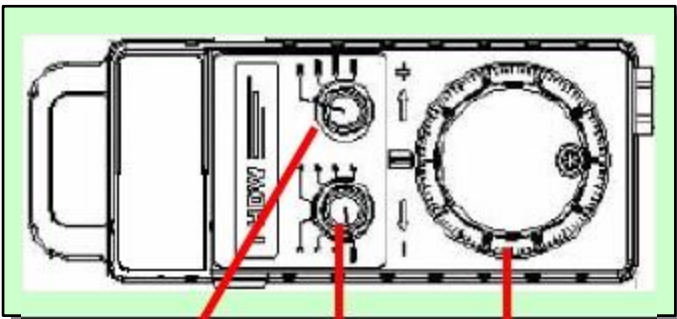

1. HANDWHEEL
FUNCTION AS ON PANEL
2. AXIS SELECT SWITCH
TO SELECET AXIS IN
MANUAL MODE
3. HANDWHEEL SCALE
MULTIPLE

3

2

1

SIGNAL LIGHT DESCRIPTION

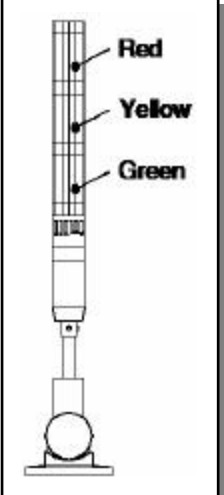

SIGNAL LIGHT AND BUZZER

A. RED (BLANKING): ALARM SIGNAL (SUCH AS OVER LOAD, LUBRICATION LOW, AIR LOW, NC ALARM, BATTERY ALARM) ELIMINATE ALARM TO CUT SIGNAL.

B. YELLOW (BLANKING): PROGRAM END (M00/M01/M30) PUSH



FEED HOLD SWITCH TO CUT SIGNAL.

C. GREEN (BLANKING): PROGRAM EXECUTING.

STATUS LAMPS DESCRIPTION







LAMP X Y Z IV AND V AXIS ZERO POSITION

THE LAMP INDICATES THAT THE TABLE (X AXIS). SADDLE (Y AXIS) AND SPINDLE HEAD (Z AXIS) ARE AT THE REFERENCE POINT (COORDINATE ZERO). THE LAMP LIGHTS WHEN REFERENCE POINT IS COMPLETED BY MANUAL OPERATION, OR RETURN TO REFERENCE POINT (G28). OR REFERENCE POINT RETURN CHECK (G27). THE LAMP GOES OUT WHEN THE TABLE, SADDLE OR SPINDLE OR SPINDLE HEAD LEAVES THE REFERENCE POINT.



PROGRAMFINISH

WHEN PROGRAM EXECUTE M02 OR M30 THIS LAMP LIGHTS

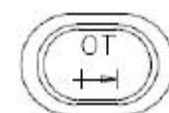
	<p>LAMP OPTIONAL STOP</p> <p>THE LAMP LIGHTS WHEN THE PROGRAM RUNS TO THE OPTIONAL STOP (M01) OR THE PROGRAM RUNS TO THE END (M00) ,</p>
	<p>LAMP LUBRICATION LEVEL (FAILURE)</p> <p>IF AMOUNT OF LUBRICATING OIL DECREASES TO ABOUT ONE FOURTH OF THE LUBRICATING OIL TANK CAPACITY, THE LAMP LIGHTS.</p> <p>SINCE THE MACHINE DOES NOT STOP AUTOMATICALLY WHEN THE LAMP LIGHTS, IMMEDIATELY STOP THE MACHINE AND REPLENISH NECESSARY AMOUNT OF OIL WHEN THE IS FOUND LIGHTING.</p> <p>WHEN THE OIL TANK IS FILLED. THE LAMP GOES OUT.</p>
	<p>LAMP OVERLOAD ·</p> <p>THE LAMP LIGHTS IF OVERLOAD OCCURS WITH THE COOLANT PUMP, LUBRICATION PUMP OR ATC MAGAZINE DRIVE MOTOR.</p> <p>SINCE THE MACHINE DOES NOT STOP AUTOMATICALLY WHEN THE LAMP LIGHTS, STOP THE MACHINE IMMEDIATELY AND EXAMINE THE THERMAL RELAYS FOR CAUSE IF THE LAMP LIGHTS. TO RESUME THE OPERATION, ELIMINATE THE CAUSE OF THE OVERLOAD.</p>
	<p>LAMP AIR PRESSURE (FAILURE)</p> <p>THE LAMP LIGHTS IF COMPRESSED AIR PRESSURE GOES DOWN BELOW 4 bar .</p> <p>THE ALARM BUZZER ALSO SOUNDS AND TOOL CHANGE BECOMES IMPOSSIBLE WHEN THIS LAMP LIGHTS.</p> <p>WHEN THE LAMP LIGHTS, STOP THE MACHINE OPERATION, CHECK AIR PRESSURE IN THE PNEUMATIC UNIT THROUGH PRESSURE GAUGE AND AIR PRESSURE TO 5.5 bar . THEN PRESS CYCLE START TO CANCEL ALM.</p>
	<p>LAMP NC ALARM</p> <p>WHEN GENERATE SEQUENCE ERROR, THIS LAMP LIGHTS</p>
	<p>OT DETECT</p> <p>WHEN X, Y, Z OR 4TH AXIS DETECT THE HARDWARE OVERTRAVEL THIS LAMP LIGHTS</p>

	LAMP ATC ALARM WHEN ATC NOT IN POSITION, THIS LAMP LIGHTS

Manual tool holder clamp/unclamp button



TOOL CLAMP / UNCLAMP

IN FRONT OF THE SPINDLE,







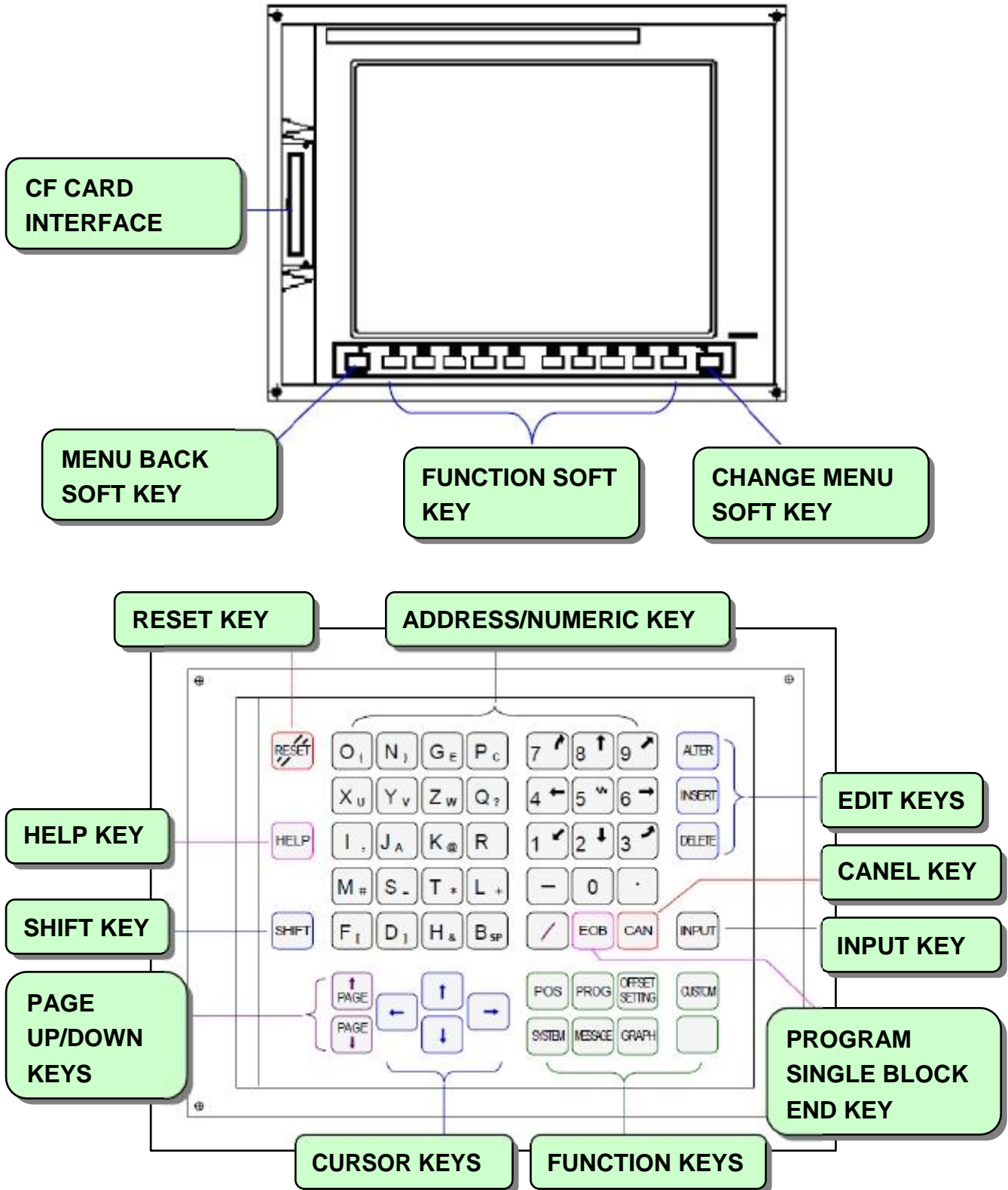







IN MANUAL MODE, PUSH TO UNCLAMP TOOL, RELEASE TO CLAMP.







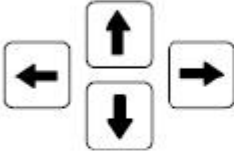

(IN DOOR OPEN STATUS)

1.2 LCD CONTROL PANEL FUNCTION



EXPLANATION OF THE KEYBOARD

No.	Key	Function
(1)	Reset key 	Used to reset the CNC to release an alarm or other similar state.
(2)	Help key 	Used to get help with operations such as for the MDI keys, when the operator does not know what to do next.
(3)	Soft keys	The soft keys are assigned different functions depending on the application. The functions currently assigned to the soft keys are displayed on the lowermost line of the screen.
(4)	Address/numeric keys   ...	Used to enter letters and numbers.
(5)	Shift key 	Some of the address keys have two different letters. When the shift key is pressed first before pressing one of these address keys, the lower-right letter is input. When the shift key is pressed, ^ is displayed in the key input buffer indicating that the lower-right letter will be input.
(6)	Input key 	Data input by pressing an address or numeric key is stored in the key input buffer, then displayed. When data input to the key input buffer needs to be written to the offset register, press the <INPUT> key. This key is equivalent to soft key [INPUT]. Either key may be used.
(7)	Cancel key 	Used to delete letters or numbers input to the key input buffer. Example) When N001X100Z is displayed on the key input buffer, pressing the cancel key deletes the letter Z, and N001X100 is displayed.
(8)	Edit keys   	Used to edit programs.  : Alter  : Insert  : Delete
(9)	Function keys   ...	Used to switch screens for each function.

No.	Key	Function
(10)	<p>Cursor keys</p> 	<p>Four cursor keys are provided.</p>  : Moves the cursor to the right or forwards in small units.  : Moves the cursor to left or backwards in small units.  : Moves the cursor downward or forwards in large units.  : Moves the cursor upward or backwards in large units.
(11)	<p>Page-up/down keys</p>  	<p>Page-up and page-down keys are provided.</p>  : Used to display the next page.  : Used to display the previous page.

Explanation of the Function Keys

The function keys select what is displayed. Each function is divided into sub-functions, and the sub-functions are selected by soft keys.

There are six function keys :  ,  ,  ,  ,  , and  .

 : Displays the current position.

 : Displays and edits a program stored in memory.

 : Displays an offset value, offset from the workpiece zero point, custom macro variable, and tool life management data. Allows data to be input into these items.

 : Displays and sets a parameter and pitch error compensation value, and displays self diagnostic data.

 : Displays an alarm message, external operator message, external alarm message, and alarm history.

 : Displays graphic data.

Explanation of the Soft Keys

The MDI panel has 10 soft keys (or 5 soft keys), a next-menu key on the right, and a previous-menu key on the left. The next menu key and previous menu key are used to select the functions of the soft keys.

These soft keys can be assigned with various functions, according to the needs.

The following functions are mainly available via the MDI panel:

- Actual position display
- Contents of program display, program directory display (display of program number, program name, part program storage length left, number of programs left)
- Program editing
- Offset amount display and setting
- Commanded value display, MDI input
- Parameter setting and display
- Alarm message/operator message display
- Custom macro variables display and setting
- Tool life management data display and setting
- Diagnosis
- Others

This manual may refer to a display device with 10 + 2 soft keys as a 12 soft key type, and a display device with 5 + 2 soft keys as a 7 soft key type.

1.3 DISPLAYING NC SCREEN

LIST OF OPERATION

CLASSIFICATION	FUNCTION	KEY SWITCH	SETTING PWE=1	MODE SWITCH BUTTON	FUNCTION BUTTON	OPERATION
CLEAR	MEMORY ALL CLEAR			POWER ON	—	[RESET] AND [DELETE]
	PARAMETER AND OFFSET		○	POWER ON	—	[RESET]
	CLEARING STORED PROGRAM		○	POWER ON	—	[DELETE]
RESET	RUN TIME			—	—	[R/3] → [CAN]
	PARTS NUMBER			—	—	[P/Q] → [CAN]
	OT ALARM			POWER ON	—	[P/Q] AND [CAN]
DATA INPUT FROM MDI	PARAMETER			MDI	PARAM	[P/Q] → PARAM. NO. → [INPUT] → [DATA] → [INPUT] → PWE=0 → [RESET]
	OFFSET VALUE		○	—	OFFSET	[P/Q] → OFFSET NO. → [INPUT] → OFFSET DATA → [INPUT]
	SETTING DATA			MDI	PARAM	[P/Q] → 0 → [INPUT] → DATA → [INPUT]
	PMC PARAMETER	○			DGNOS	[P/Q] → DIAGRAM NO. → [INPUT] → DATA → [INPUT]
	TOOL LENGTH MEASUREMENT			JOG	POS OFFSET	[POS] (RELATIVE) → [Z] → [CAN] → [OFFSET] → MOVE TOOL TO MEASURING POSITION →
						[P / Q] → OFFSET NO. → [EOB] AND [Z] → [INPUT]
DATA INPUT FROM TAPE	PARAMETER (TAPE TO MEMORY)		○	EDIT	PARAM	[INPUT]
	OFFSET VALUE	○		EDIT	OFFSET	[INPUT]
	PROGRAM INPUT			EDIT / AUTO	PRGRM	[INPUT]
TAPE PUNCH	PARAMETER			EDIT	PARAM	[START]
	OFFSET VALUE			EDIT	OFFSET	[START]

	ALL PROGRAM			EDIT	PRGRM	[0] → -999 → [START]
	ONE PROGRAM			EDIT	PRGRM	[0] → PROGRAM NO. → [START]
SEARCH	PROGRAM NO. SEARCH			EDIT / AUTO	PRGRM	→ [0] PROGRAM NO. → [↓] (CURSOR)
	SEQUENCE NUMBER SEARCH			AUTO	PRGRM	PROGRAM NO. SEARCH → [N] → SEQUENCE NO. → [↓] (CURSOR)
	ADDRESS WORD SEARCH			EDIT	PRGRM	SEARCHING ADDRESS AND DATA INPUT → [↓] (CURSOR)
	OFFSET NO.			—	OFSET	[P/Q] → OFFSET NO. → [INPUT]
PROGRAM EDITING	PROGRAM MEMORY USED			EDIT	PRGRM	[P] → [INPUT]
	DELETION OF ALL PROGRAM	○		EDIT	PRGRM	[0] → [9999] → [DELETE]
	DELETION OF A PROGRAM	○		EDIT	PRGRM	[0] → PROGRAM NO. → [DELETE]
	DELETION OF SEVERAL BLOCKS	○		EDIT	PRGRM	[N] → SEQUENCE NO. → [DELETE]
	DELETION OF A BLOCKS			EDIT	PRGRM	[EOB] → [DELETE]
	DELETION OF A WORD	○		EDIT	PRGRM	SEARCH THE WORD TO BE DELETED → [DELETE]
	ALTERNATION OF A WORD	○		EDIT	PRGRM	SEARCH THE WORD TO BE ALTERED → NEW DATA → [ALTER]
	INSERTION OF A WORD	○		EDIT / AUTO	PRGRM	SEARCH THE WORD TO BE INSERTED → NEW DATA → [INSERT]
COLLATION	COLLATION IN MEMORY WITH TAPE			EDIT / AUTO	PRGRM	[INPUT]
INPUT / OUTPUT WITH FANUC CASSETTE	PROGRAM INPUT	○		EDIT / AUTO	PRGRM	[N] → FILE NO. → [INPUT] → [INPUT]
	OUTPUT ALL PROGRAM			EDIT	PRGRM	[0] → -9999 → [START]
	OUTPUT ONE PROGRAM			EDIT	PRGRM	[0] → PROGRAM NO. → [INPUT]

	SEARCHING FOR A HEAD OF A FILE			EDIT / AUTO	PRGRM	[N] → FILE NO. , -9999 OR -9998 → [INPUT]
	DELETION OF FILE	○		EDIT	PRGRM	[N] → FILE NO. → [START]
	COLLATION OF PROGRAM			EDIT / AUTO	PRGRM	[N] → FILE NO. → [INPUT] → [INPUT]
PLAYBACK				TEACHIN JOG / HANDLE	PRGRM	MOVE MACHINE → [X] , [Y] OR [Z] → [INSERT] → NC DATA [INSERT] → [EOB] → [INSERT]

FOR MORE INFORMATION PLEASE REFER TO FANUC OPERATOR'S MANUAL

MDI KEYBOARD FUNCTION

NO.	NAME	FUNCTION
1	RESET KEY	PRESS THIS KEY TO RESET THE CNC, TO CANCEL AN ALARM, ETC.
2	START	PRESS THIS KEY TO START THE MDI COMMENDS, OR TO START THE AUTOMATIC OPERATION CYCLE.
3	ADDRESS AND NUMERICAL KEY	PRESS THIS KEYS TO INPUT ALPHABETIC, NUMERIC, AND OTHER CHARACTER.
4	INPUT KEY	WHEN AN ADDRESS OR A NUMERICAL KEY IS PRESSED, THE ALPHABET OR THE NUMERAL IS INPUT ONCE TO THE KEY INPUT BUFFER, AND IT IS DISPLAYED ON THE CRT SCREEN. TO SET THE DATA INPUT TO THE KEY INPUT BUFFER IN THE OFFSET REGISTER, ETC. , PRESS THE INPUT KEY. THIS KEY IS EQUIVALENT TO THE INPUT KEY OF THE SOFT KEYS, SO THE SAME RESULTS CAN BE OBTAINED BY PRESSING EITHER OF THEM.
5	CANCEL (CAN) KEY	PRESS THIS KEY TO CANCEL CHARACTER OR SIGN. (EXAMPLE) WHEN THE KEY INPUT BUFFER DISPLAY N0001, N0001 IS CANCELED WITH THIS KEY.
6	CURSOR SHIFT KEYS	THERE ARE TWO KINDS OF CURSOR SHIFT KEY DESCRIBED BELOW : ↑ : THIS KEY IS USED TO SHIFT THE CURSOR A SHOUT DISTANCE IN THE FORWARD DIRECTION. ↓ : THIS KEY IS USED TO SHIFT THE CURSOR A SHOUT DISTANCE IN THE REVERSE DIRECTION.
7	PAGE CHANGEOVER KEY	TWO KINDS OF PAGE CHANGEOVER KEYS ARE DESCRIBED BELOW : ↑ : THIS KEY IS USED TO CHANGEOVER THE PAGE ON THE CRT SCREEN IN THE FORWARD DIRECTION. ↓ : THIS KEY IS USED TO CHANGEOVER THE PAGE ON THE CRT SCREEN IN THE REVERSE DIRECTION.

8	SOFT KEYS	<p>THE SOFT KEY HAVE VARIOUS FUNCTIONS, ACCORDING TO THE APPLICATIONS.</p> <p>THE SOFT KEY FUNCTIONS ARE DISPLAYED AT THE BOTTOM OF THE CRT SCREEN.</p> <p>LEFT-END SOFT KEY ←</p> <p>THIS KEY IS USED IN ODDER TO EXIT TO THE INITIAL STATES (CONDITION WHEN THE FUNCTION BUTTON IS DEPRESSED WHEN EACH FEATURE HAS BEEN OPERATED VIA SOFT KEYS)</p> <p>RIGHT-END SOFT KEY →</p> <p>THIS KEY IS USED WHEN OPERATE FUNCTIONS WHICH HAVE NOT YET BEEN DISPLAYED.</p>
---	-----------	---

2. M_CODE LIST

2.1 M_CODE LIST SELECT

SPINDLE

M Code	Define
M03	Spindle CW
M04	Spindle CCW
M05	Spindle stop
M19	Spindle orientation
M29	Rigid tapping

PROGRAMMING

M Code	Define	M Code	Define
M00	Program Stop	M24	A axis mirror image
M01	Optional program stop	M30	Program End
M02	Program end	M46	Override cancel
M21	X axis mirror image on	M98	Call sub-program
M22	Y axis mirror image on	M99	Program re-start / Return to main program
M23	Mirror image off		

COOLANT

M Code	Define	M Code	Define
M07	Cutting air blow on	M15	High pressure coolant chip remove on
M08	Coolant pump on	M16	High pressure coolant chip remove off
M09	Coolant pump off	M48	CTS on
M10	Cutting air blow off	M50	Chip conveyor CW
M13	Spindle CW and coolant on	M51	Chip conveyor stop
M14	Spindle CCW and coolant on		



TOOL CHANGE

M Code	Define	M Code	Define
M06	Auto tool change	M71	Tool pot down
M41	Magazine extend for M6 macro	M72	Arm move to catch tools
M42	Magazine tool command search for M6 macro	M74	Arm move to exchange tools
M52	Magazine extend	M76	Arm return to home position
M53	Magazine return	M77	Tool pot up
M66	Auto tool change start for M6	M90	Magazine search tool number command
M70	Automatic tool data table re-building	M95	Arm trouble shooting

3. SETTING / CHANGING MACHINE PARAMETER

3.1 DISPLAYING PARAMETERS

Follow the procedure below to display parameters.

- 1 Press the  function key on the MDI as many times as required, or alternatively, press the  function key once, then the PARAM section display soft key. The parameter screen is then selected.

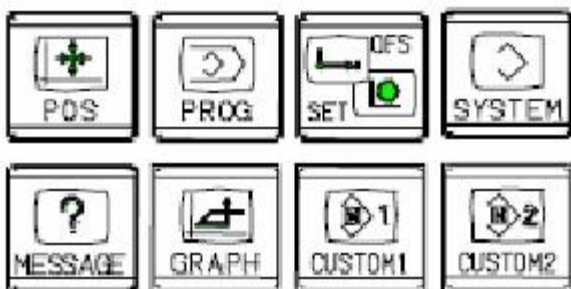
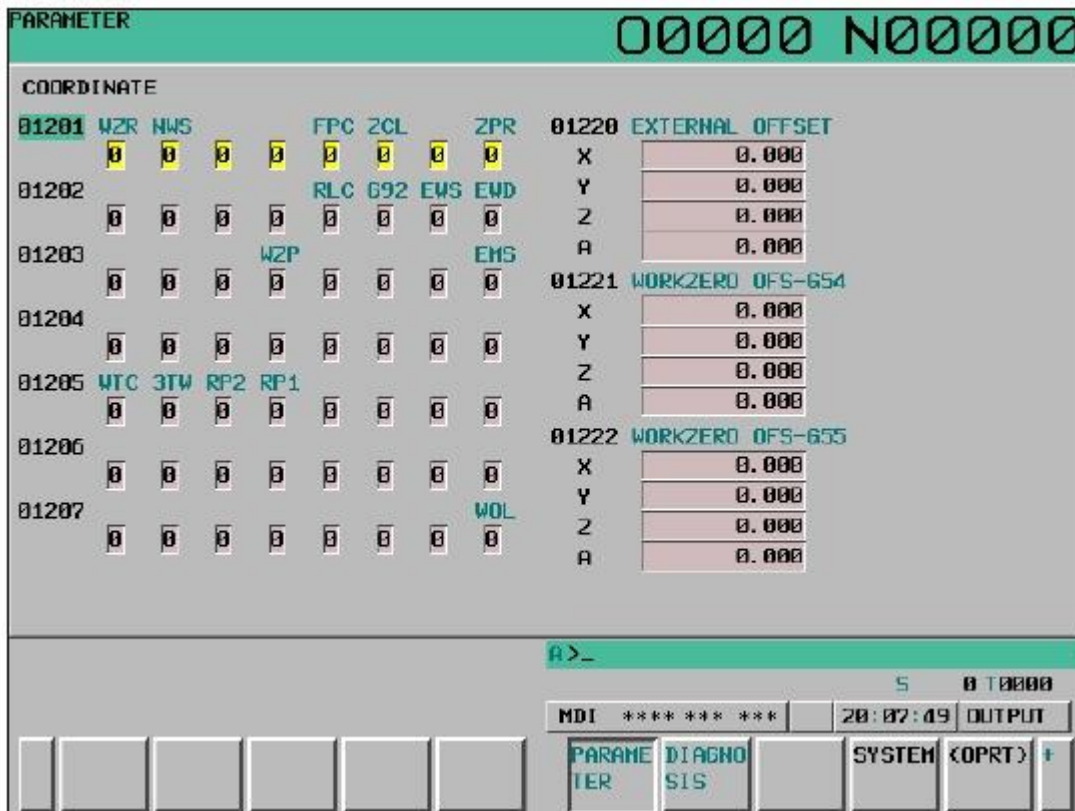

Function keys

- 2 The parameter screen consists of multiple pages. Use step (a) or (b) to display the page that contains the parameter you want to display.
 - (a) Use the page select key or the cursor move keys to display the desired page.
 - (b) Enter the data number of the parameter you want to display from the keyboard, then press the [NO.SRH] soft key. The parameter page containing the specified data number appears with the cursor positioned at the data number. (The data is displayed in reverse video.)





NOTE

If key entry is started with the section select soft keys displayed, they are replaced automatically by operation select soft keys including [NO.SRH]. Pressing the [(OPRT)] soft key can also cause the operation select keys to be displayed.

3.2 SETTING PARAMETERS FROM MDI

Follow the procedure below to set parameters.



- 1 Place the NC in the MDI mode or the emergency stop state.
- 2 Follow the substeps below to enable writing of parameters.
 - 2-1 To display the setting screen, press the  function key as many times as required, or alternatively press the  function key once, then the [SETTING] section select soft key. (The first page of the setting screen appears.)



- 2-2 Position the cursor on "PARAMETER WRITE" using the cursor move keys.
- 2-3 Press the [(OPRT)] soft key to display operation select soft keys.



- 2-4 To set "PARAMETER WRITE=" to 1, press the [ON:1] soft key, or alternatively enter 1 and press the [INPUT] soft key. From now on, the parameters can be set. At the same time an alarm condition (SW0100 PARAMETER WRITE ENABLE) occurs in the CNC.

- 3 To display the parameter screen, press the  function key as many times as required, or alternatively press the  function key once, then the PARAM section select soft key. (See Chapter 1, "DISPLAYING PARAMETERS.")
- 4 Display the page containing the parameter you want to set, and position the cursor on the parameter. (See Chapter 1, "DISPLAYING PARAMETERS.")
- 5 Enter data, then press the [INPUT] soft key. The parameter indicated by the cursor is set to the entered data.

SETTING (PARAMETER)								
SETTINGS								
00000			SEQ		INI	ISO	TUC	
	0	0	0	0	0	1	0	
00001						FCV		
	0	0	0	0	0	0	0	
00002	SJZ							
	0	0	0	0	0	0	0	
00010					PEC	PRM	PZS	
	0	0	0	0	0	0	0	

Data can be entered continuously for parameters, starting at the selected parameter, by separating each data item with a semicolon (;).

[Example] Entering 10;20;30;40 and pressing the INPUT key assigns values 10, 20, 30, and 40 to parameters in order starting at the parameter indicated by the cursor.

- 6 Repeat steps (4) and (5) as required.
- 7 If parameter setting is complete, set "PARAMETER WRITE=" to 0 on the setting screen to disable further parameter setting.
- 8 Reset the NC to release the alarm condition (SW0100).
If an alarm condition (PW0000 PLEASE TURN OFF POWER) occurs in the NC, turn it off before continuing operation.

4. Opening / Closing doors

4.1 Opening / Closing Splashguard Door

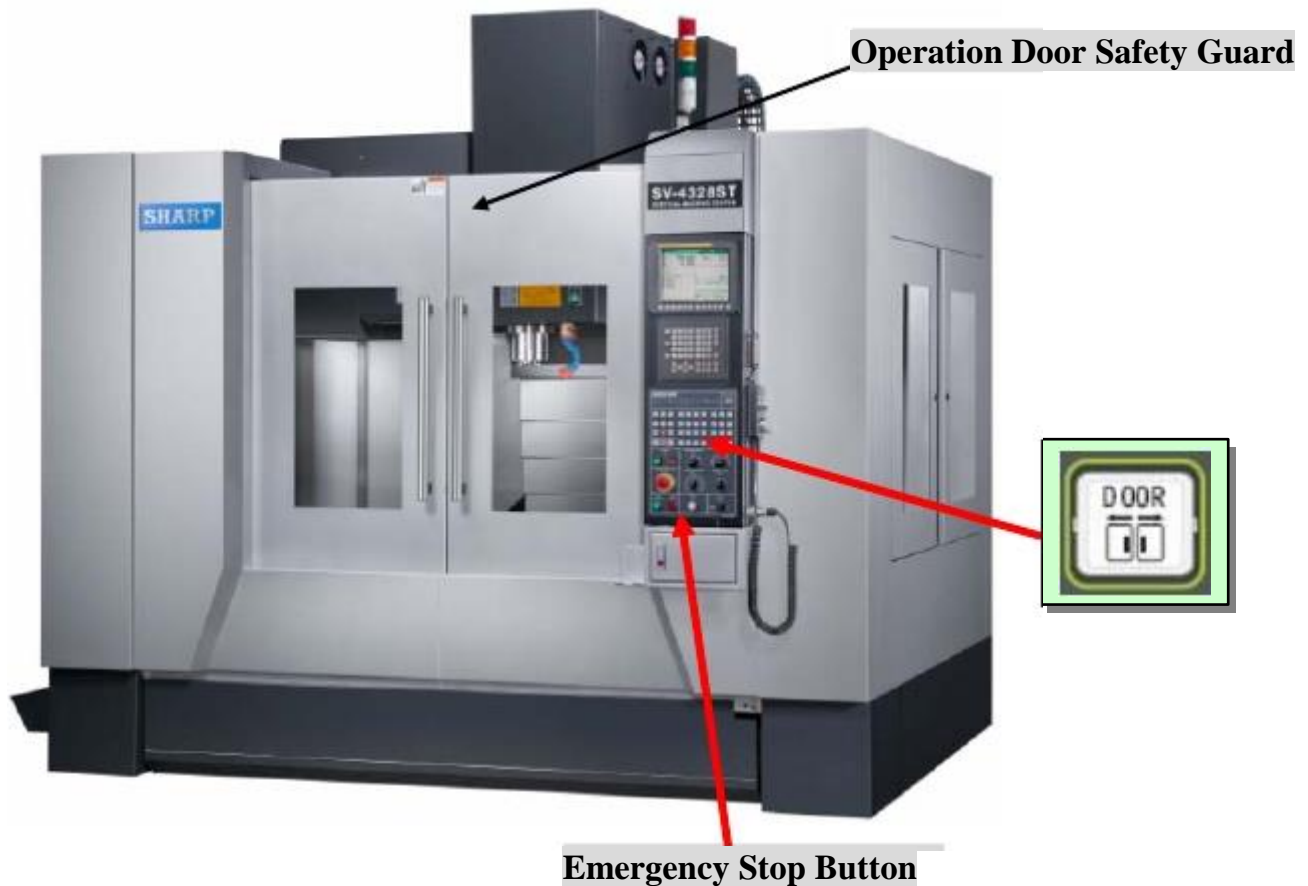
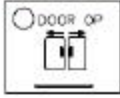

Figure 4.1 position of splashguard door and operation

OPERATE IN DOOR OPEN STATUS WITH NON CE DOOR INTERLOCK SWITCH (OPTION)

- A. WHEN NON CE DOOR INTERLOCK SWITCH IS MOUNTED, PRESS THIS KEY



TO RELEASE DOOR INTERLOCK.

- B. RELEASE DOOR INTERLOCK IN ANY MODE.
- C. CAN OPERATE ONLY IN JOG AND HANDWHEEL MODE WHEN DOOR OPENED
- D. DUE TO SAFETY REASON, WHILE DOOR OPEN THE MACHINE CAN ONLY OPERATE IN FOLLOWING STATUS.
- a. SPINDLE SPEED UNDER 50/min
 - b. CAN OPERATE ONLY IN JOG AND HANDWHEEL MODE.
 - c. AXIS FEED RATE UNDER 2000mm/min.
- E. CLOSE DOOR TO RESUME SYSTEM.

OPERATE IN DOOR OPEN STATUS WITH CE DOOR INTERLOCK SWITCH (OPTION)

- A. CONDITION IN DOOR OPEN STATUS

DUE TO CE REGULATION AND SAFETY REASON, WHILE DOOR OPEN THE MACHINE CAN ONLY OPERATE IN FOLLOWING STATUS.

- a. SPINDLE SPEED UNDER 50 /min.
- b. CAN OPERATE ONLY IN JOG AND HANDWHEEL MODE.
- c. AXIS FEEDRATE UNDER 2000 mm/min

- B. HOW TO OPERATE IN DOOR OPEN STATUS

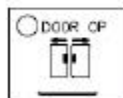

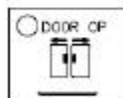
- a. PUSH DOOR OPEN  BUTTON.
- b. AFTER ENABLE THIS BUTTON, THE LAMP IN THE BUTTON LIGHTS.

NOTICE: ONCE YOU PUSH THIS BUTTON, YOU MUST EXECUTE OPEN AND CLOSE DOOR PROCEDURE TO RESUME THE SYSTEM.

- c. OPEN THE DOOR.
 - d. CLOSE DOOR TO RESUME SYSTEM.
- C. MOVE THE AXIS OR TURN THE SPINDLE IN MANUAL MODE.

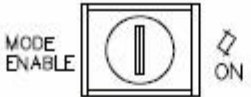
- a. SWITCH KEY  TO MODE ENABLE.



- b. SWITCH MODE TO "MANUAL" (HANDLE, JOG.)

NOTE: MAKE SURE NOW MAGAZINE ON INITIAL POSITION.

- c. BEFORE ANY MOVEMENT, KEEP PUSHING THE PERMISSIVE

BUTTON 

- FOR MACHINE WITH REMOVEABLE HANDWHEEL, THE BUTTON IS ON THE SIDE OF THE HANDWHEEL.
 - FOR MACHINE WITHOUT REMOVEABLE HANDWHEEL, THIS BUTTON IS ON THE OPERATION PANEL.
- d. DURING ANY MOVEMENT, YOU MUST KEEP PUSHING PERMISSIVE BUTTON TO ENABLE THE MOVEMENT.

NOTICE: DON'T RELEASE THE PERMISSIVE BUTTONS BEFORE STOP THE MOVEMENT. IT WILL CAUSE THE FAILURE OF THE MOVEMENT.

5. TURNING ON / OFF POWER SUPPLY

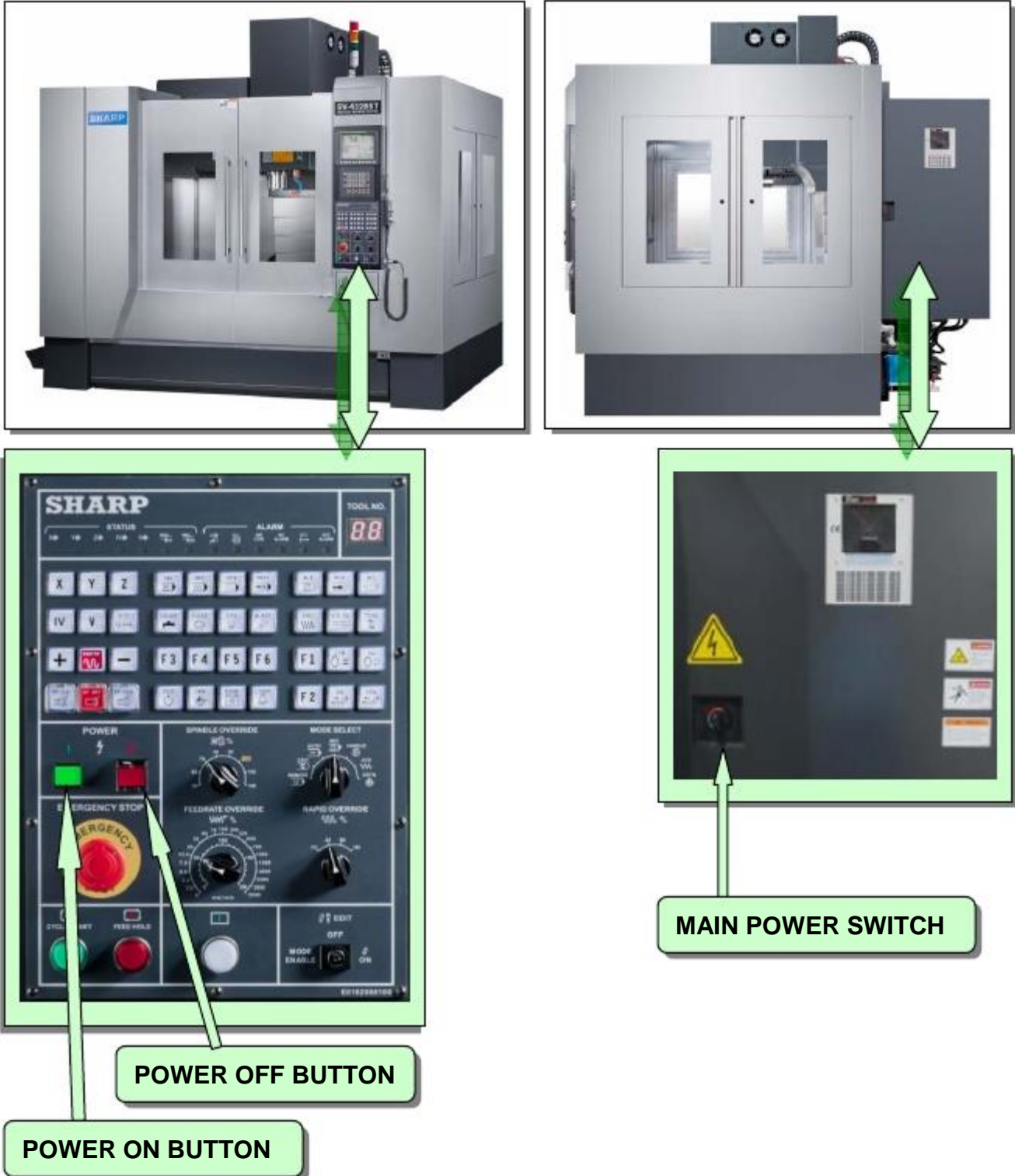







Figure 5.1 LOCATION OF POWER SUPPLY SWITCH AND BUTTON

SWITCHING ON THE POWER SOURCE TO MACHINE

- D. HOLD DOWN THE PUSH BUTTON POWER ON THE NC OPERATION PANEL FOR 2 OR 3 sec. THE POWER SOURCE WILL BE GIVEN THROUGHOUT THE MACHINE.
- E. REFERRING TO THE DESCRIPTION OF CHECKING BEFORE STARTING THE MACHINE IN DAILY CHECKING BEFORE STARING THE MACHINE IN DAILY CHECKING SCHEDULE 6.1, MAKE SURE NO TROUBLE IS FOUND IN THE MACHINE AND THEN START THE OPERATION.

MOVE AXIS TO REFERENCE POINT (MANUALLY)

MOVE SPINDLE HEAD (Z AXIS), SADDLE (Y AXIS), TABLE (X AXIS) TO THE REFERENCE POINT (COORDINATE ZERO)

- A. SWITCH KEY  TO MODE ENABLE
- B. SET THE MODE SWITCH  TO ZRTN POSITION.
- C. SET THE SWITCH "RAPID OVERRIDE"  TO 25%.
- D. PRESS THE PUSH BUTTON  UNTIL THE ZERO (REFERENCE POINT) LAMP "Z" LIGHTS (THEN,  FOR X AXIS AND  FOR Y AXIS)

SWITCHING OFF THE POWER SOURCE

TO TURN OFF, PROCEED AS FOLLOW:

- A. MAKE SUR THE FRONT DOOR IS CLOSED
- B. MAKE SURE THAT THE LAMP OF THE CYCLE START ON PUSH BUTTON ON THE OPERATION PANEL DOES NOT LIGHT.
- C. MAKE SURE THAT ALL MOVABLE PARTS OF THE MACHINE ARE IN STANDSTILL.
- D. WHEN TAPE PUNCH UNIT (ASR33 OR RS-232C) IS USED, TURN OFF THE UNIT.
- E. THEN HOLD THE PUSH BUTTON POWER OFF ON THE NC OPERATION PANEL FOR 1 OR 2 SEC.
- F. TURN OFF THE POWER SWITCH ON THE ELECTRIC BOX.

6. DATA REGISTRATION / EDITING

6.1 NC Program Registration (3 Methods)

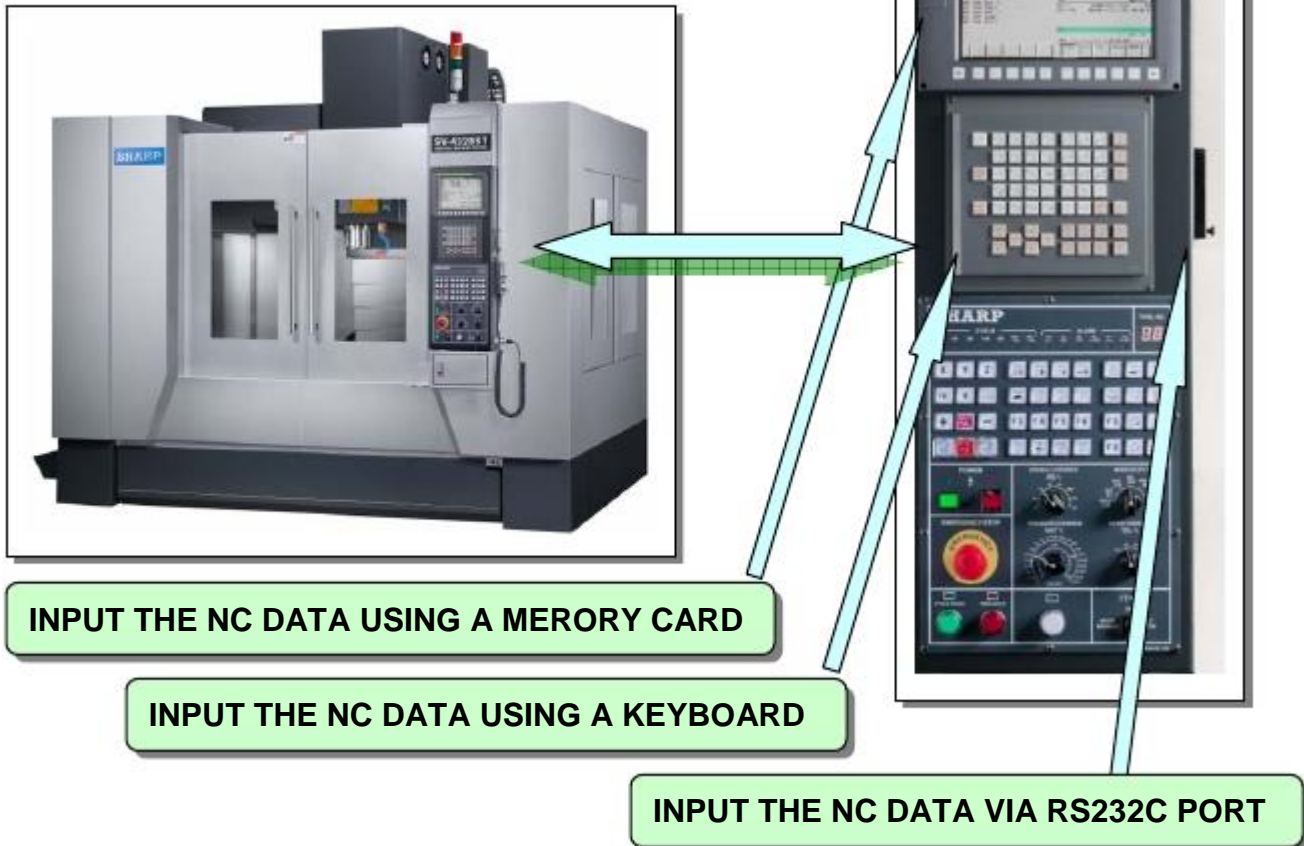



Figure 6.1 POSITION OF RS232C PORT / MEMORY CARD INTERFACE / KEYBOARD

6.2 Tool Offset Registration

Press function key  to display or set tool compensation values and other data.

This section explains how to display and specify the following:

1. Tool compensation value
2. Tool length measurement

Refer to the User's Manual (Common to Lathe System/Machining Center System) (B-64304EN) for explanations about how to display or specify the other types of data.



Setting and Displaying the Tool Compensation Value

Tool offset values, tool length compensation values, and cutter compensation values are specified by D codes or H codes in a program. Compensation values corresponding to D codes or H codes are displayed or set on the screen.

There are two tool offset memory types, A and C.

Procedure for setting and displaying the tool compensation value

Procedure

- 1 Press function key .
- 2 Press chapter selection soft key [OFFSET] or press function key  several times until the tool compensation screen is displayed.

The screen varies according to the type of tool compensation memory.

Tool Compensation Memory A

OFFSET						00123 N00000		
NO.	DATA	NO.	DATA	NO.	DATA	RELATIVE		
001	0.000	010	0.000			X	150.000	
002	0.000	019	0.000			Y	100.000	
003	0.000	020	0.000			Z	50.000	
004	0.000	021	0.000			B	0.000	
005	0.000	022	0.000			C	0.000	
006	0.000	023	0.000			ABSOLUTE		
007	0.000	024	0.000			X	150.000	
008	0.000	025	0.000			Y	100.000	
009	0.000	026	0.000			Z	50.000	
010	0.000	027	0.000			B	0.000	
011	0.000	028	0.000			C	0.000	
012	0.000	029	0.000			MACHINE		
013	0.000	030	0.000			X	150.000	
014	0.000	031	0.000			Y	100.000	
015	0.000	032	0.000			Z	50.000	
016	0.000					B	0.000	
017	0.000					C	0.000	

MEM **** * 12:00:00

<	NO. SRH	INP. C.	+INPUT	INPUT	ERASE	F INPUT	F OUTPUT		
---	---------	---------	--------	-------	-------	---------	----------	--	--

Tool Compensation Memory C

OFFSET					00123 N00000				
NO.	<LENGTH>		<RADIUS>		RELATIVE				
	GEOM	WEAR	GEOM	WEAR	X	Y	Z	B	C
001	0.000	0.000	0.000	0.000	150.000	100.000	50.000	0.000	0.000
002	0.000	0.000	0.000	0.000					
003	0.000	0.000	0.000	0.000					
004	0.000	0.000	0.000	0.000					
005	0.000	0.000	0.000	0.000					
006	0.000	0.000	0.000	0.000					
007	0.000	0.000	0.000	0.000					
008	0.000	0.000	0.000	0.000					
009	0.000	0.000	0.000	0.000					
010	0.000	0.000	0.000	0.000					
011	0.000	0.000	0.000	0.000					
012	0.000	0.000	0.000	0.000					
013	0.000	0.000	0.000	0.000					
014	0.000	0.000	0.000	0.000					
015	0.000	0.000	0.000	0.000					
016	0.000	0.000	0.000	0.000					

ABSOLUTE				
X	Y	Z	B	C
150.000	100.000	50.000	0.000	0.000

MACHINE				
X	Y	Z	B	C
150.000	100.000	50.000	0.000	0.000

R>

MEM	****	***	***	12:00:00
<	NO. SRH	IMP. C.	+INPUT	INPUT
ERASE	F INPUT	F OUTPUT		

- 3 Move the cursor to the compensation value to be set or changed using page keys and cursor keys, or enter the compensation number for the compensation value to be set or changed and press soft key [NO.SRH].
- 4 To set a compensation value, enter a value and press soft key [INPUT].
To change the compensation value, enter a value to add to the current value (a negative value to reduce the current value) and press soft key [+INPUT]. Or, enter a new value and press soft key [INPUT].

Explain

- Decimal point input

A decimal point can be used when entering a compensation value.

- Other setting method

An external input/output device can be used to input or output a tool offset value. See Chapter III-8 in User's Manual (Common to T/M). A tool length compensation value can be set by measuring the tool length as described in the next subsection.

- Tool compensation memory

There are tool compensation memories A and C, which are classified as follows:

Tool compensation memory A

D codes and H codes are treated the same. Tool geometry compensation and tool wear compensation are treated the same.

Tool compensation memory C

D codes and H codes are treated differently. Tool geometry compensation and tool wear compensation are treated differently.

Bit 6 (NGW) of parameter No. 8136 can be used to specify whether to use tool offset memory C ("0" for specifying to use it and "1" for specifying not to use it). If tool offset memory C is not used, tool offset memory A is used.

6.3 Number Of Tool Offset Value

Bit 5 (NDO) of parameter No. 8136 can be used to specify whether to use 400 tool offset values ("0" for specifying to use 400 tool offset values and "1" for specifying not to use them). If the number of tool offset values to be used is not 400, the number of tool offset values to be used is 32.

- Disabling entry of compensation values

The entry of compensation values may be disabled by setting bit 0 (WOF) and bit 1 (GOF) of parameter No.3290 (not applied to tool compensation memory A).

In this case, it is possible to prohibit any range of tool offset values from being entered from the MDI by setting the start tool offset value number in parameter No. 3294 and the quantity of offset values counted from the beginning of the range in parameter No.3295.

If an attempt is made to enter tool offset values including those prohibited, the following occur:

- 1) When compensation values are input consecutively from offset numbers for which the input of values is enabled to offset numbers for which the input of values is inhibited, a warning is issued, but the compensation values in the range of the offset numbers for which the input of values is enabled are set.
- 2) When compensation values are input consecutively from offset numbers for which the input of values is inhibited to offset numbers for which the input of values is enabled, a warning is issued and the compensation values are not set.

6.4 Registration Of Workpiece Offset Value

Displaying and Setting the Workpiece Origin Offset Value

Procedure for displaying and setting the workpiece origin offset value



Procedure

- 1 Press function key .
- 2 Press chapter selection soft key [WORK].
The workpiece coordinate system setting screen is displayed.



- 3 The screen for displaying the workpiece origin offset values consists of two or more pages.

Display a desired page in either of the following two ways:

- Press the page key  or .
 - Enter the workpiece coordinate system number (0 : external workpiece origin offset, 1 to 6: workpiece coordinate systems G54 to G59) and press operation selection soft key [NO.SRH].
- 4 Turn off the data protection key to enable writing.
 - 5 Move the cursor to the workpiece origin offset to be changed.
 - 6 Enter a desired value by pressing numeric keys, then press soft key [INPUT]. The entered value is specified in the workpiece origin offset value. Or, by entering a desired value with numeric keys and pressing soft key [+INPUT], the entered value can be added to the previous offset value.
 - 7 When performing counter input, enter the axis name in the key-in buffer and press soft key [C INPUT] to set the relative coordinates of the specified axis.
 - 8 Repeat steps 5, 6, and 7 to change other offset values.
 - 9 Turn on the data protection key to disable writing.

Direct Input of Workpiece Origin Offset Value Measured

This function is used to compensate for the difference between the programmed workpiece coordinate system and the actual workpiece coordinate system. The measured offset for the origin of the workpiece coordinate system can be input on the screen such that the command values match the actual dimensions.

Selecting the new coordinate system matches the programmed coordinate system with the actual coordinate system.

Procedure for direct input of workpiece origin offset value measured

Procedure

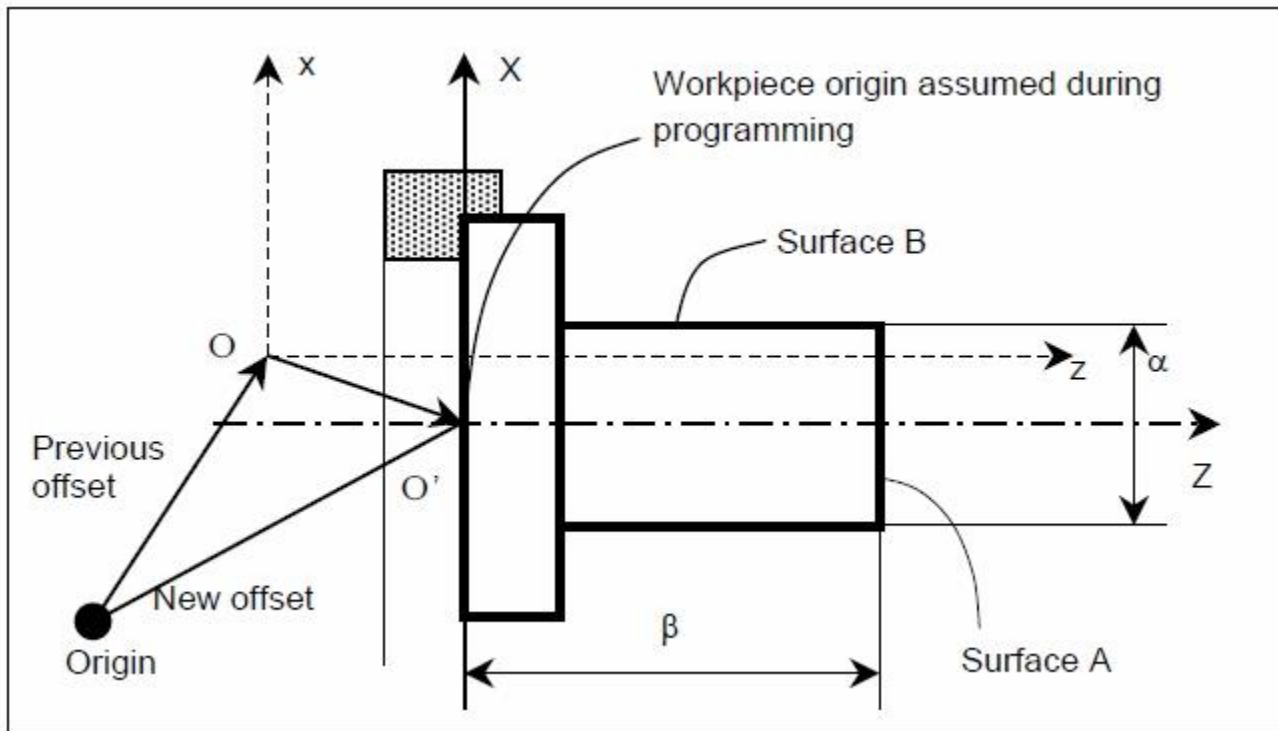

- 1 For the workpiece shown above, cut surface A in manual operation.
- 2 Retract the tool only in the X-axis direction without moving the Z-axis and stop the spindle.
- 3 Measure distance β between surface A and the programmed origin of the workpiece coordinate system as shown above.
- 4 Press function key .

- To display the WORK COORDINATES screen, press the chapter selection soft key [WORK].

ACTUAL POSITION				N00000					
ABSOLUTE				F 10 MM/MIN					
*X	151.945			PARTS COUNT 458					
Z	100.000			RUN TIME 4H 0M CYCLE TIME 0H 0M 2S					
Y	50.000			WORK COORDINATES					
C	0.000			(G54)					
MODAL				NO. DATA NO. DATA					
G00	G22	G40.1F	M	00	X	0.000	02	X	0.000
G97	G80	G50.2S		EXT	Z	0.000	G55	Z	0.000
G69	G67	G13.1			Y	0.000		Y	0.000
G99	G54	G50.1			C	0.000		C	0.000
G21	G64	G49		01	X	0.000	03	X	0.000
G40	G18	G15 SACT	0	G54	Z	0.000	G56	Z	0.000
G25	G69.16	G05.5T			Y	0.000		Y	0.000
					C	0.000		C	0.000

- Position the cursor to the workpiece origin offset value to be set.
- Press the address key for the axis along which the offset is to be set (Z-axis in this example).
- Enter the measured value (β) then press soft key [MEASUR].
- Cut surface B in manual operation.
- Retract the tool only in the Z-axis direction without moving the X-axis and stop the spindle.
- Measure diameter α of surface B and enter this value directly as the X value as described in Steps 7 and 8.

7. WORKPIECE SETTING

Workpiece attachment and detachment



1. WORKPIECE ATTACHMENT AND DETACHMENT

Workpiece restrictions



2. WORKPIECE RESTRICTIONS

1. WORKPIECE ATTACHMENT AND DETACHMENT



1-1

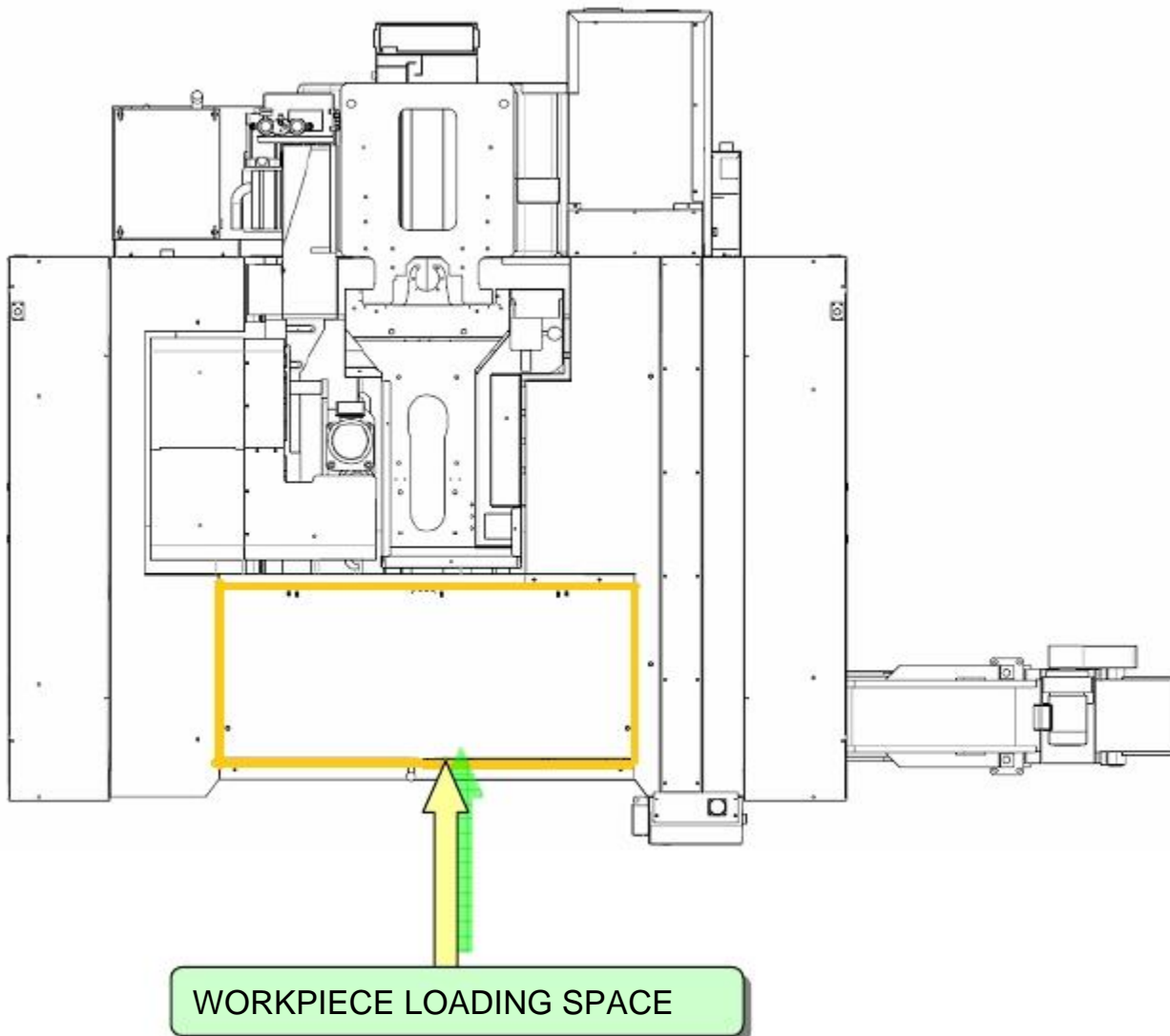

Figure 1-1 POSITION OF WORKPIECE ATTACHMENT AND DETACHMENT

2. WORKPIECE RESTRICTIONS

- 1) Load Capacity : 1000Kgs
- 2) Table size : Shown in Figure 8.2

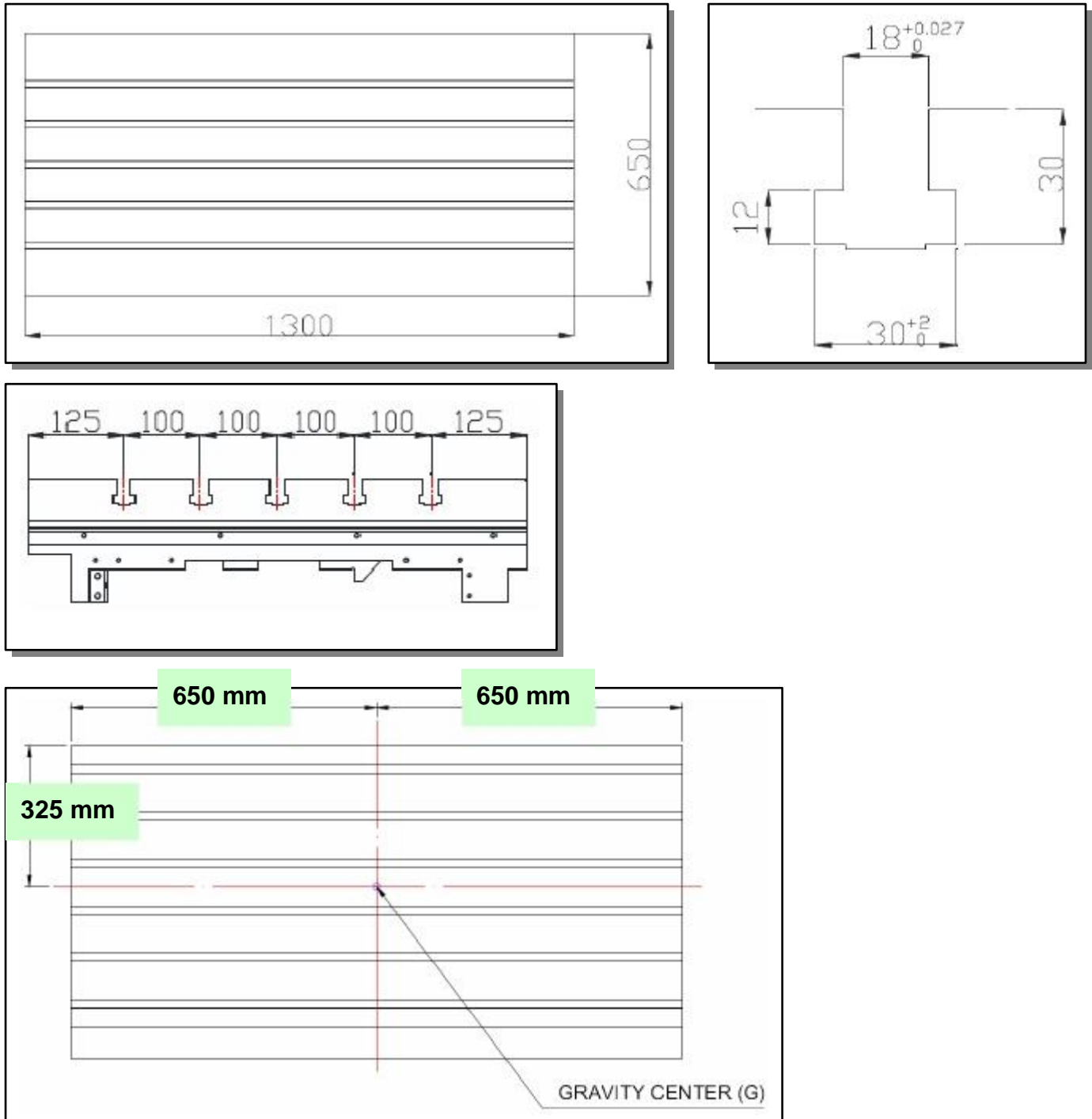

Figure 8.2 WORKPIECE RESTRICTIONS

8. TOOL PREPARATIONS

8.1 Tool Attachment and Detachment (Figure 1-1)

- 1) Make sure the spindle is at a complete stop and ready for a tool change .
- 2) Firmly insert the tool in the spindle .
- 3) Press the tool clamp / unclamp button (Figure 1-2) on the front of the head .
- 4) Release the tool clamp / unclamp button .
- 5) Make sure the tool is completely and correctly inserted before releasing the tool .



Figure 1-1 Tool Attachment and Detachment



Figure 1-2 Tool clamp / unclamp button

8.2 Tool storage limitations

Items	Maximum Value
Storage Capacities	24 Tools
Maximum Tool Diameter Allowed for Continuous Mounting	125(4.9) mm(inch)
Maximum Tool Diameter with Adjacent Post Empty	200(7.8) mm(inch)
Maximum Tool Length	300 (11.8) mm(inch)
Maximum Tool Weight	6 (13.2) kg(lb)

8.3 Tool And Retention Stud combinations

BT SHANK

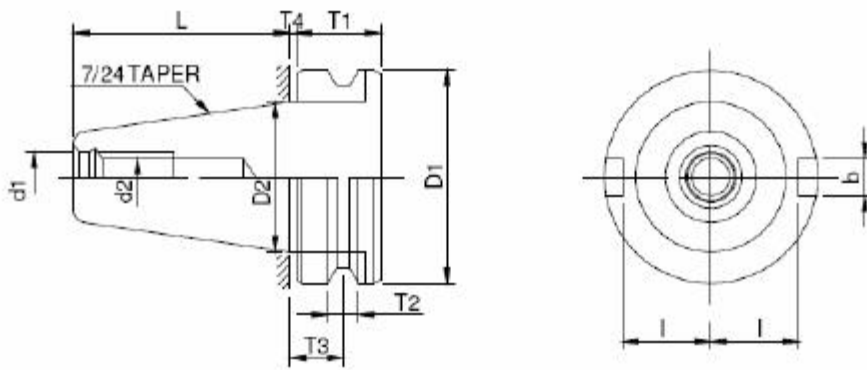

Unit : mm

Model No.	D1	D2	d1	d2	L	T1	T2	T3	T4	b	l
BT 40	63	44.45	17	M16	65.4	25	10	16.6	2	16.1	22.6

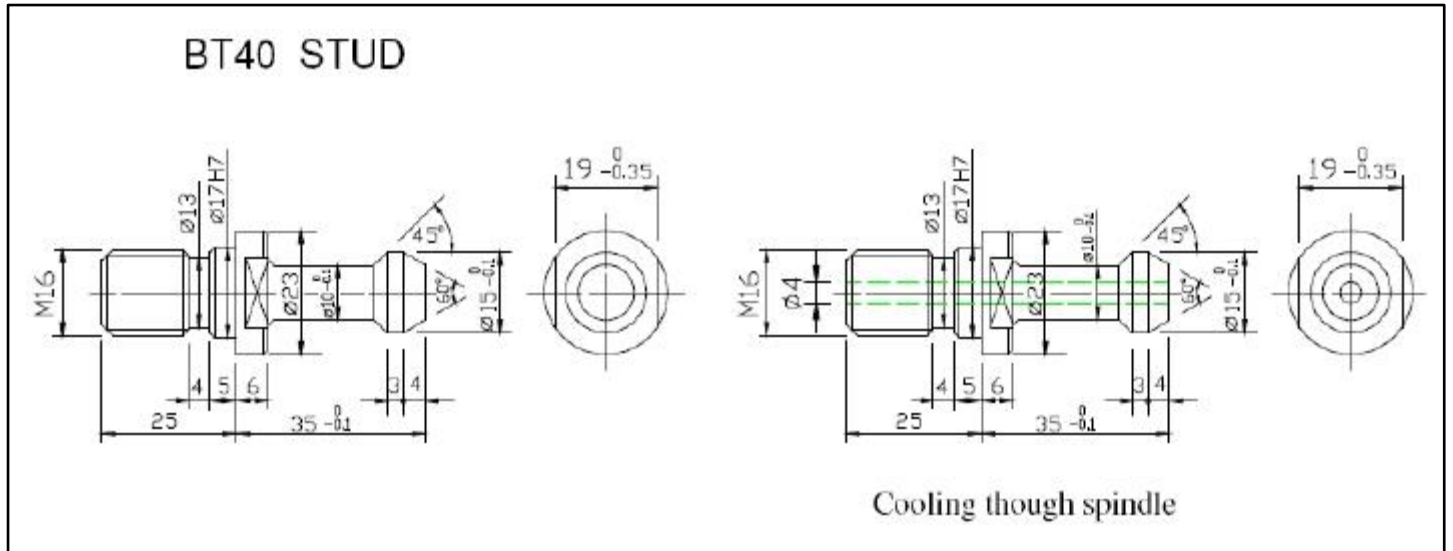

CAT SHANK

(ANSI B5.50-78)

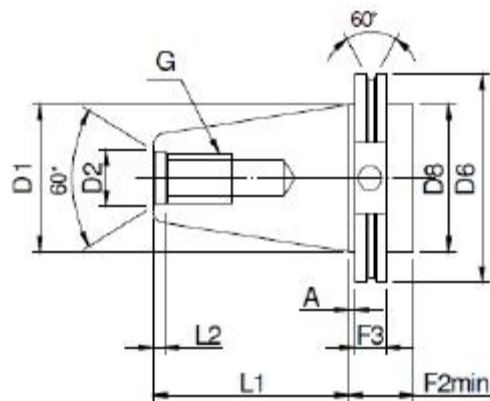

Unit : mm

Model No.	D1	D2	D6	D8	L1	L2	F2	F3	A	G
CAT 40	1.750 (44.45)	0.641 (16.28)	2.5 (63.05)	1.75 (44.45)	2.687 (68.25)	0.188 (4.78)	1.375 (35.00)	0.625 (15.88)	0.125 (3.18)	5/8-11 thread

CAT 40 STUD

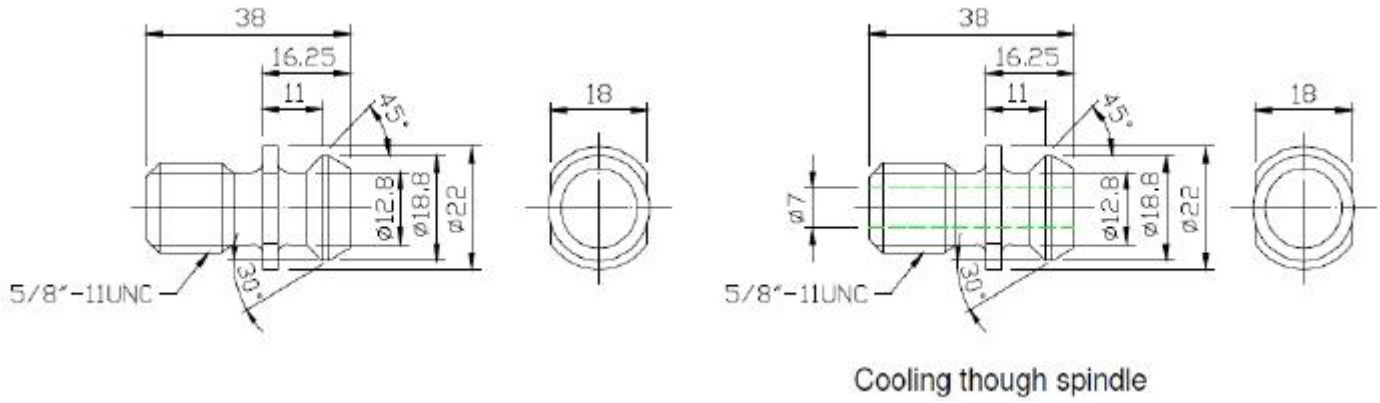

DIN 69871A SHANK

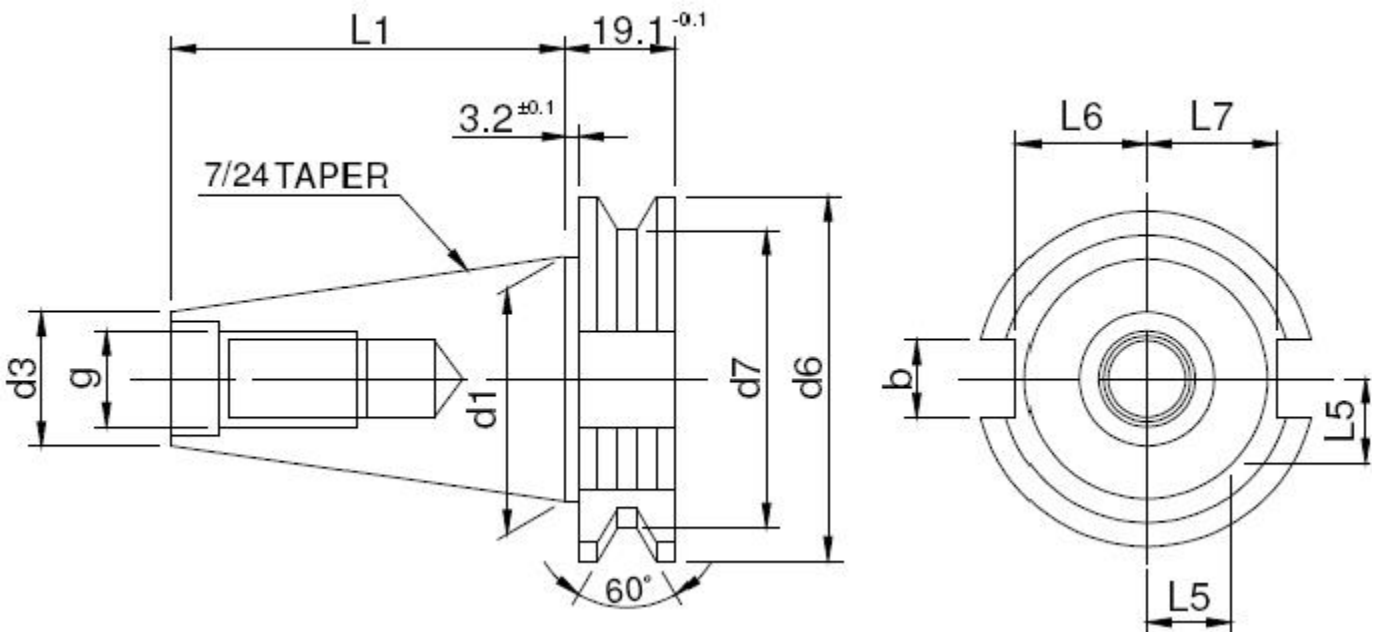

Unit : mm

Model No.	B H12	d1	g	d3 H7	d6 -0.1	d7	L1 -0.3	L5 -0.3	L6 -0.4	L7 -0.4
DIN 40	16.1	44.45	M16	17	63.55	56.25	68.4	18.5	22.8	25

9. Tool CHANGES

- A. THE T FUNCTION IS USED TO COMMAND THE NUMBER OF TOOL TO BE CHANGED.
- B. THE DESIRED TOOL CAN BE DIRECTLY COMMENDED WITH ADDRESS T FOLLOWED BY 2-DIGIT NUMERIC VALUE. TOOL FUNCTION IS AVAILABLE WITHIN A RANGE FROM T01 TO T20.24.32.40,

EXAMPLE :

- C. WHEN SPINDLE TOOL IS CHANGED TO NO. 2 TOOL, PROGRAM AS FOLLOW :

T02 (EOB)

M06 (EOB)

- NOW TOOL NO.2 WILL BE CHANGED TO SPINDLE.
- NOTE THAT THE COMMAND SHOULD BE TWO BLOCKS.

- D. WHEN SPINDLE TOOL IS CHANGED TO NO.2 TOOL AND CALL TOOL NO.3 AS THE PREPARED TOOL.

T02 (E0B)

M06 T03 (E0B)

- NOW TOOL NO.2 WILL BE CHANGED TO SPINDLE AND TOOL NO.3 WILL BE ROTATED TO STANDBY POSITION.

10. CUTTING FLUID SUPPLY



10.1 CUTTING FLUID SUPPLY UNIT FOR SPINDLE

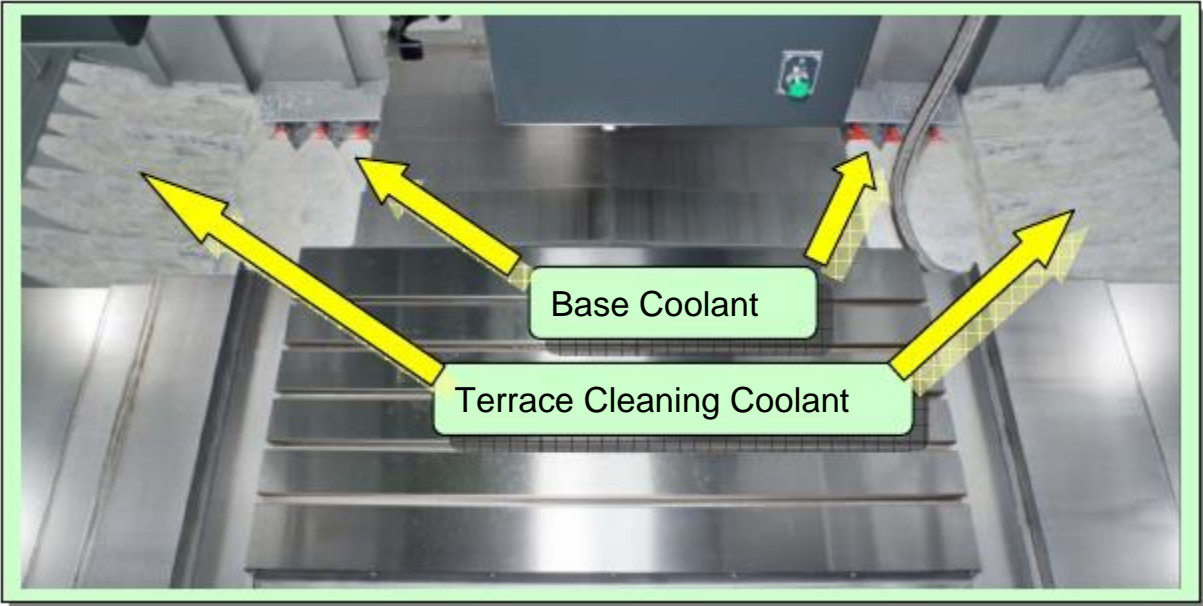

10.2 CUTTING FLUID SUPPLY UNIT FOR BASE

Table 10.1 CUTTING FLUID SUPPLY UNIT OPERATION CHART

Unit	Setting Method	
	Main Operation Panel	M-Code
Spindle Side Coolant		M08 (Start) M09 (Stop) M13 (SPINDLE CW / COOLANT PUMP ON) M14 (SPINDLE CW / COOLANT PUMP OFF)
Base Coolant (Terrace Cleaning Coolant)		M15 (Start) M16 (Stop) M13 (SPINDLE CW / COOLANT PUMP ON) M14 (SPINDLE CW / COOLANT PUMP OFF)
Through- Spindle Coolant		M48 (Start) M09 (Stop)

11. CHIP DISPOSAL

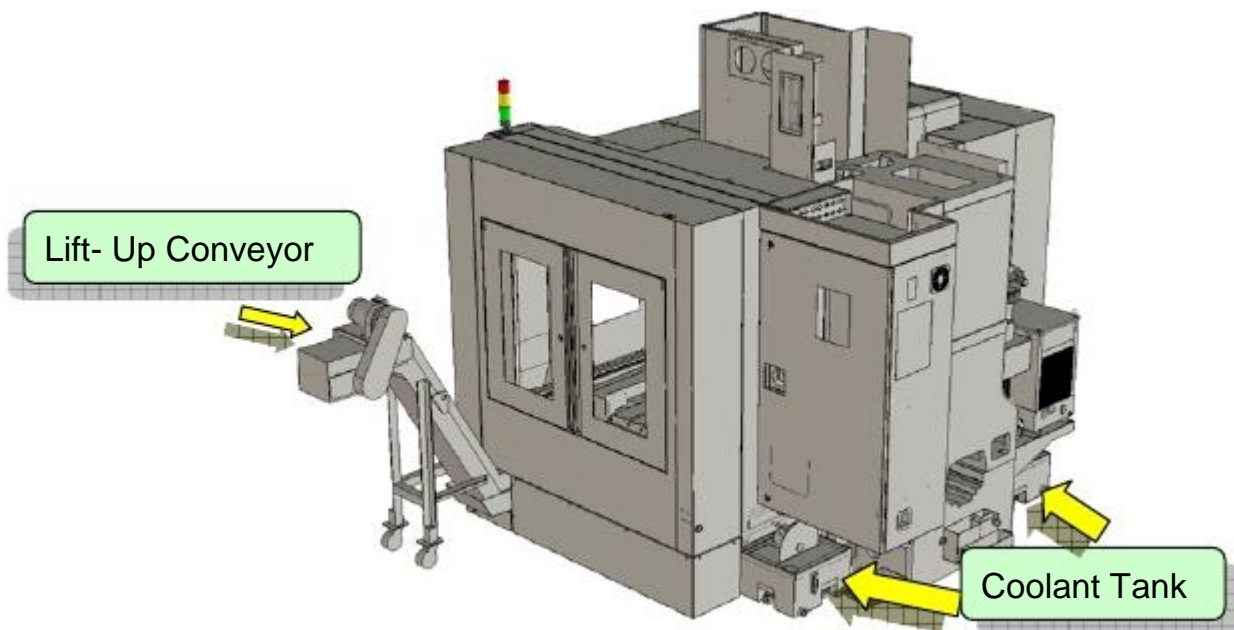

Figure 11.1 LIFT- UP CONVEYOR

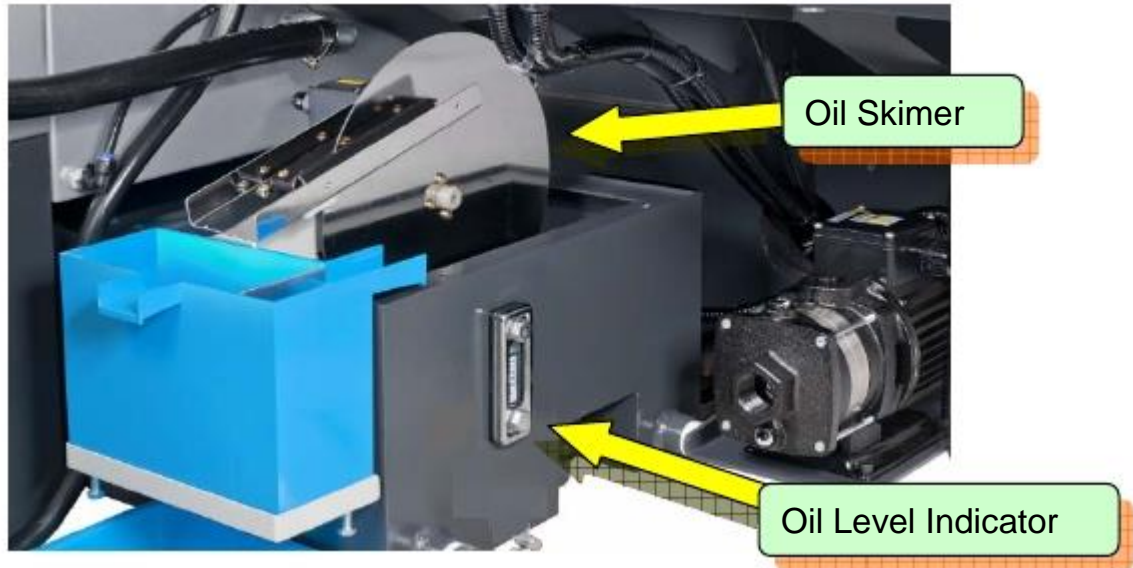

Figure 11.2 OIL SKIMER & OIL LEVEL INDICAOR

11.1 OPERATION OF LIFT-UP CONVEYOR

A. Automatic Operation

Conveyor forward operation is performed in connection with the cutting fluid discharge start command .

B. Manual Operation

1) Forward Manual Operation

a. Press the “CW” button as below, the conveyor rotation in forward direction .



b. Press the “CW” button again, the conveyor be stop .

2) Reverse Manual Operation

a. Keep pressing the “CCW “ button as below, the conveyor rotation in reverse direction .



b. Release the “CCW “button , the conveyor be stop .

2. cutting tools and cutting conditions.

Choose proper tools by considering the material of work piece. Then, choose cutting conditions for each tools.

3. Manners for fixing the work piece.

Choose a proper fixing manner and the fixture. Then, consider the position relation among the tool, fixture and the machine when the workpiece is fixed wheather there is any problem due to interference or cutting incapable.

2. Program Configuration

A program is devided as a main program and subprograms. The controller works by following commands in the program. When the main program calls a subprogram, the controller will follow the command to enter the subprogram.

Program Configuration

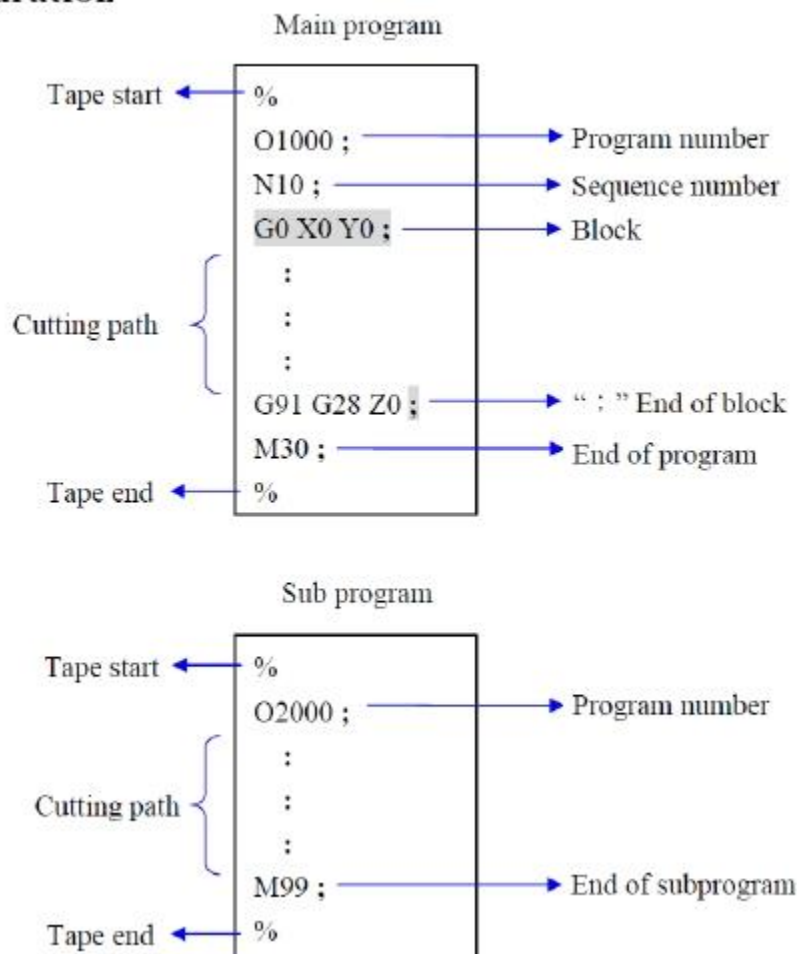

1. Tape start

The symbol indicates the start of a program file.

2. Program number

A program number consists of the address O followed by a four-digit number. In ISO code, the colon (:) can also be used as the address O. Program numbers 9000 to 9999 are usually used by machine tool builders.

Parameter

No.	Meaning
3201#3	When address O of a program number is output in ISO code 0 : “ : ” is output. 1 : “ O ” is output.

3. Sequence number

- (1) Arrange blocks in order for easy searching.
- (2) Arrange process sequences.
- (3) Call the block for program re-start.
- (4) Call the sequence NO. in program with the command M99.



4. Block

A block contains one or several commands.

Command = Address + Number



5. End of block

By pressing the key of END OF BLOCK EOB, the symbol “ ; ” is displayed on the screen.

6. End of program

M02 : End a program and the cursor “ _ ” stays at this block.

M30 : End a program and the cursor “ _ ” returns the beginning of the program.

M99 : Return the main program from the subprogram.

Parameter

No.	Meaning
3404#5	When M02 is specified in memory operation 0 : the head of the program is automatically searched for. 1 : the head of the program is not searched for.

7. Tape end

The symbol indicates the end of a program file.

3. Subprogram Call

If there is the same path for repeating, the program can be simplified with a subprogram.

Format :

M98 PXXXX □□□□ ;

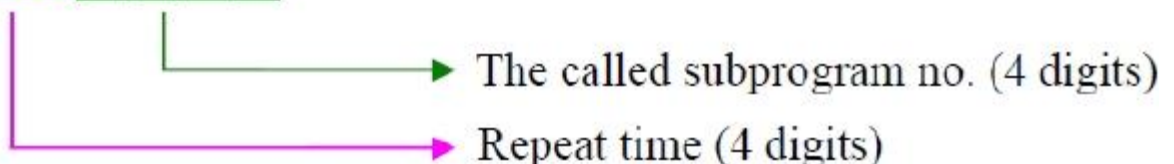

M99 ; → End the subprogram and return the main program.

or

M98 P□□□□ LXXXX ;

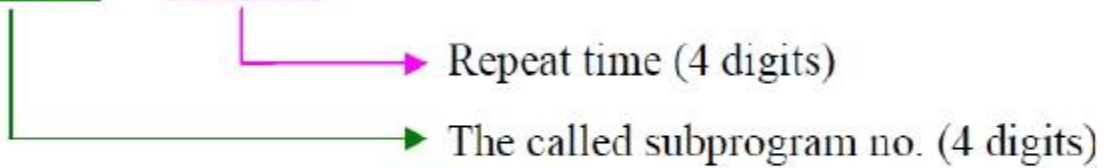

M99 ; → End the subprogram and return the main program.

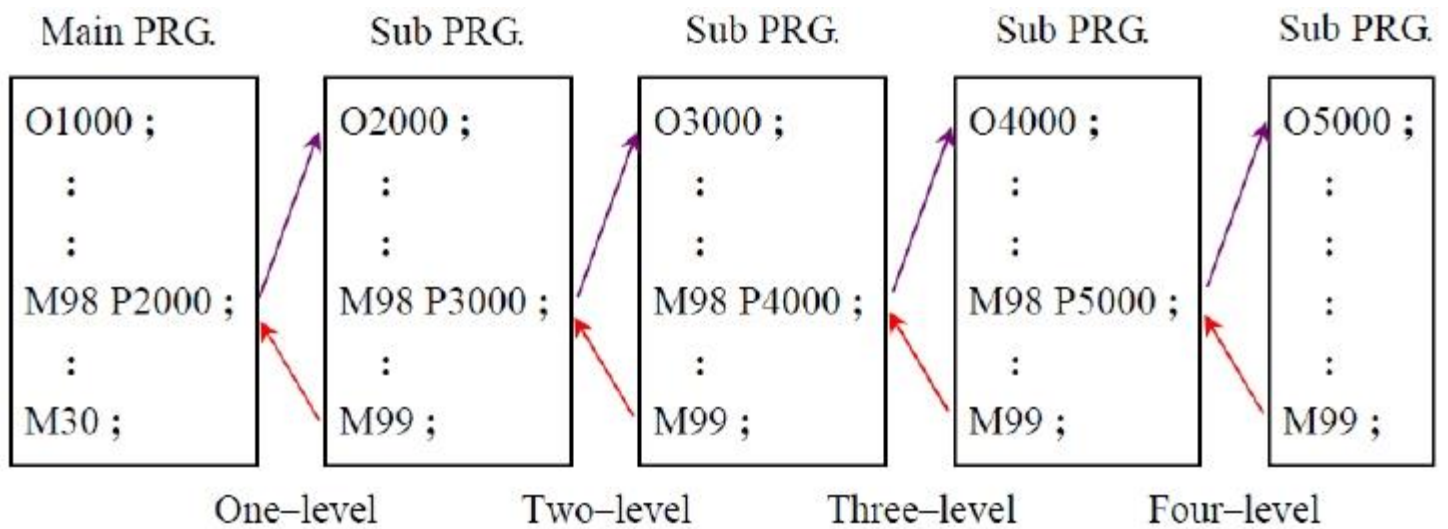

- (1) When the repeat time is omitted, it is supposed to be 1.
- (2) The most levels for calling subprograms are 4 levels.
- (3) If the subprogram NO. cannot be found, the alarm No. 78 occurs.





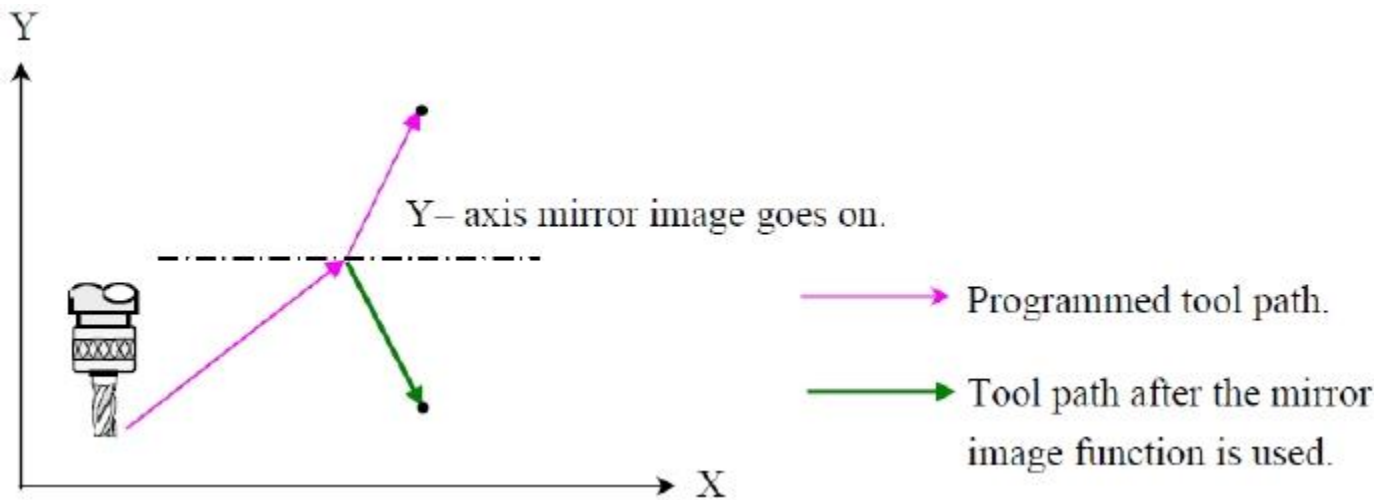

4. Major Functions And Address

Address	Meaning
O	Program number
N	Sequence number
G	Specifies a motion mode (linear, arc, etc.)
X, Y, Z U, V, W A, B, C	Coordinate axis
I, J, K	Coordinate of the arc center
R	Arc radius
F	F Function (Feedrate)
S	S Function (Spindle speed)
T	T Function
M	M Function
H, D	Offset number
P, X	Dwell time
P	Subprogram No. called
L	Repeat time of a called subprogram
N	Sequence no. in program
P, Q, R	Canned cycle parameter

5. Force Mirror Image

The cutting path in the program can be done such as that in mirror for the specified axis. Please refer to the figure.



1. Under the MDI mode, press the function key .
2. Press the soft key [SETTING], press page change keys  .
3. Move the cursor to the mirror image axis by pressing cursor keys  .
4. Press the numeric key  and then the input key , or press the soft key [(OPRT)] and then the soft key [ON : 1].

The mirror image function can also be turned on and off by parameter setting.

No.	Meaning
12 # 1	Mirror image for each axis is 0 : OFF 1 : ON



6. Program Edit

Program Number Search

1. Under the EDIT mode, press the function key .
2. Enter a program number.
3. Press the menu key [O SRH].

Note : If there is no the called program number, the alarm No. 071 DATA NOT FOUND will occur.

7. ADD New Program

1. Under the EDIT mode, press the function key .
2. Press the MDI key , then enter a program number.
3. Press the insert key .

Note : If the input new program no. is repeated to another existed program number, the alarm No. 073 PROGRAM NUMBER ALREADY IN USE will occur.

8. Deleting Programs

1. Under the EDIT mode, press the function key **PROG**.

2. Path1. Deleting a program.

Press the MDI key **O₁**, then enter a program number.

Path2. Deleting all programs stored.

Press the MDI key **O₁**, then enter - 9 9 9 9.

Path3. Deleting multiple programs with program nos. continuous in program directory.

Press the MDI key **O₁**, then enter the first program number.

Press the MDI keys **SHIFT** **|**, **O₁**, then enter the last program number.

Example : Deleting programs number O2001 to O2005.









Press MDI key **O₁** **2↓** **0** **0** **1↙** **SHIFT** **|**,
O₁ **2↓** **0** **0** **5↗**

3. Press the delete key **DELETE**, the programs with the entered program numbers are deleted.

9. Program Commanded Search

For searching the position of a command, moving cursor keys or the manner of searching are used.



Operation of moving cursors :

1. Pressing the cursor key , the cursor moves forward word by word on the screen.
2. Pressing the cursor key , the cursor moves backward word by word on the screen
3. Pressing the cursor key , the first word of the previous block is searched.
4. Pressing the cursor key , the first word of the next block is searched.
5. Press the page change key  to display the previous page and search for the first word of this page.
6. Press the page change key  to display the next page and search for the first word of this page.

Operating of searching manner :

1. Under the MDI mode, enter the command to be searched.
2. Press the soft key [SRH ↓] to search forward or
press the soft key [SRH ↑] to search backward.

Example : Searching for M06

- (1) Press the MDI key   .
- (2) Press the soft key [SRH ↓].

Note : (1) The 0 in the entered command cannot be omitted. For example, when searching the M09, never enter M9.
(2) The command must be entered completely.
For example, when searching the F180, never enter such as F1 or F18.
(3) If there is no position found out for the entered command, the alarm No. 071 DATA NOT FOUND will occur.

10. Edit Key

Inserting a Word

1. Under the MDI mode, enter “ the command to be inserted ”.
2. Press the insert key . The entered command will be inserted at the position after the cursor.



Example : Insert M08 after F5000.

```
PROGRAM                                03400 N00000
03400 (TEST) ;
(G54X=0Y=0 H1=-300. D10=8. ) ;
G0 G40 G80 G49 ;
G90 G54 X0 Y0 ;
G43 Z10. H01 M3 S100 ;
G01 Z-5. F5000 ;
G42 X10. Y-20. D10 ;
Y-35. ;
G02 X-10. Y-35. R10. ;

) M08 ^
S 0 T0000
EDIT **** **
```



The current position of the cursor.

(1) Press the MDI key   .

(2) Press the insert key .

```
PROGRAM                                03400 N00000
03400 (TEST) ;
(G54X=0Y=0 H1=-300. D10=8. ) ;
G0 G40 G80 G49 ;
G90 G54 X0 Y0 ;
G43 Z10. H01 M3 S100 ;
G01 Z-5. F5000 M08 ;
G42 X10. Y-20. D10 ;
Y-35. ;
G02 X-10. Y-35. R10. ;

) ^
S 0 T0000
EDIT **** **
```

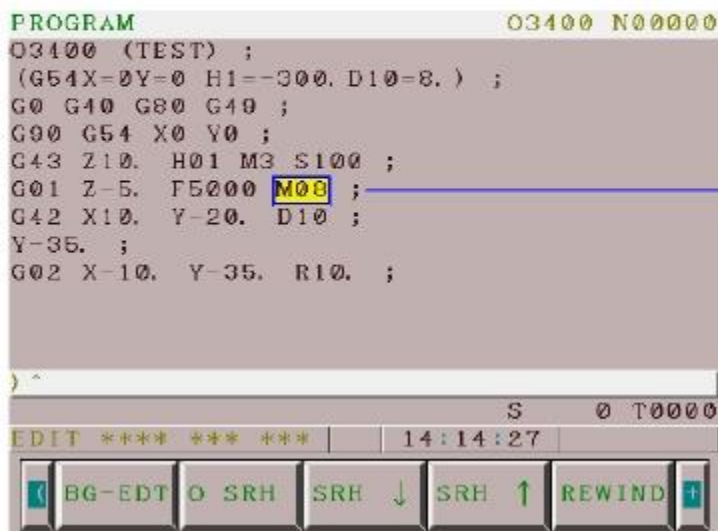

The position of the inserted command.

Altering a Word

1. Under the MDI mode, enter the command to be altered.
2. Press the alter key . The entered command will alter the original command at the position of the cursor.



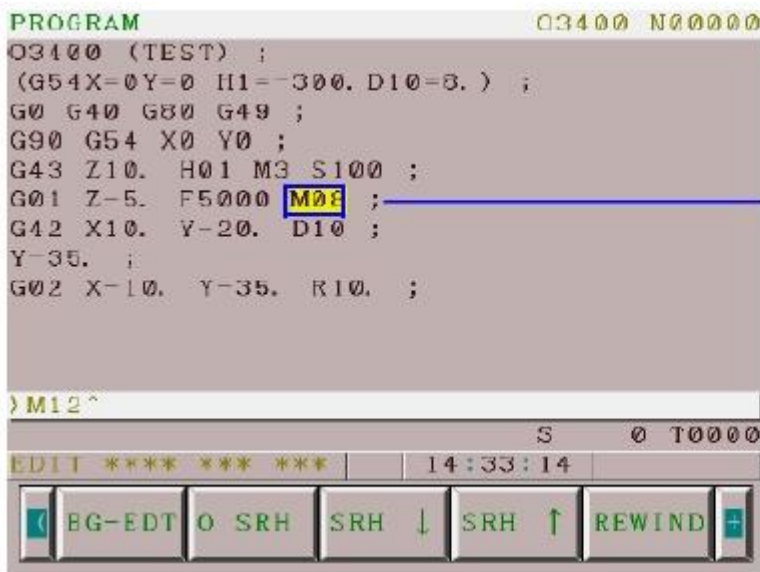

Example : Change M08 to M12.

```
PROGRAM O3400 N000000
O3400 (TEST) ;
(G54X=0Y=0 H1=-300. D10=8.) ;
G0 G40 G80 G49 ;
G90 G54 X0 Y0 ;
G43 Z10. H01 M3 S100 ;
G01 Z-5. F5000 M08 ;
G42 X10. Y-20. D10 ;
Y-35. ;
G02 X-10. Y-35. R10. ;

)M12^
S 0 T0000
```



The command
to be altered.

- (1) Press the MDI key   
- (2) Press the alter key .

```
PROGRAM O3400 N000000
O3400 (TEST) ;
(G54X=0Y=0 H1=-300. D10=8.) ;
G0 G40 G80 G49 ;
G90 G54 X0 Y0 ;
G43 Z10. H01 M3 S100 ;
G01 Z-5. F5000 M12 ;
G42 X10. Y-20. D10 ;
Y-35. ;
G02 X-10. Y-35. R10. ;

)^
S 0 T0000
```

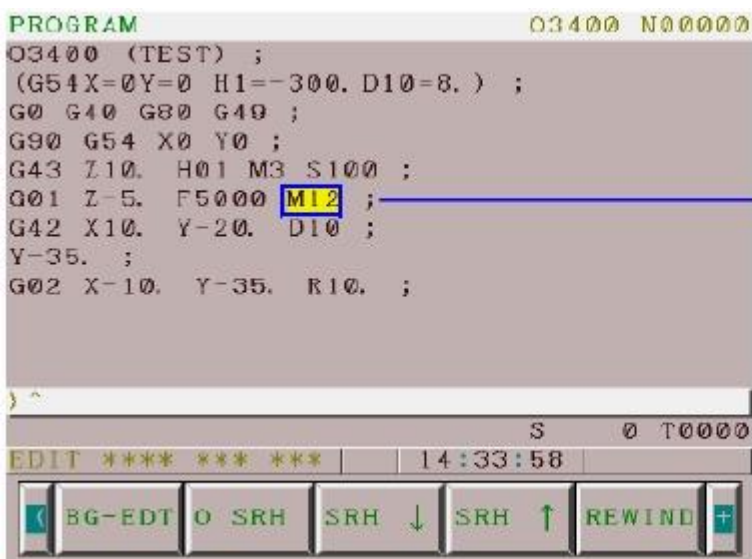

The command
after altering.

Deleting a Word

A. Deleting a command :

1. Move the cursor to the command to be deleted.
2. Press the delete key  to delete that command immediately.

Example : Delete M08.

```
PROGRAM                                O3400 N00000
O3400 (TEST) ;
(G54X=0Y=0 H1=-300. D10=8.) ;
G0 G40 G80 G40 ;
G90 G54 X0 Y0 ;
G43 Z10. H01 M3 S100 ;
G01 Z-5. F5000 M08 ;
G42 X10. Y-20. D10 ;
Y-35. ;
G02 X-10. Y-35. R10. ;

)M12^
S 0 T0000
EDIT **** ** ** 14:33:14
```

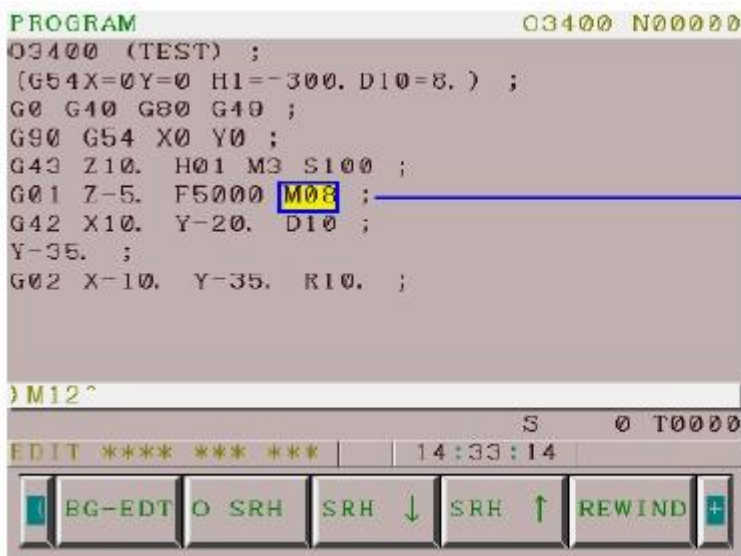

The command
to be deleted.

Press the delete key 

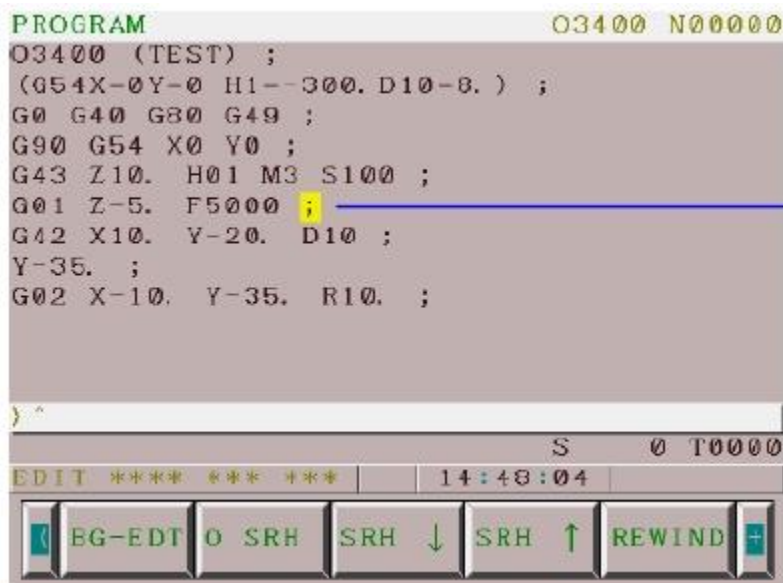

```
PROGRAM                                O3400 N00000
O3400 (TEST) ;
(G54X=0Y=0 H1=-300. D10=8.) ;
G0 G40 G80 G40 ;
G90 G54 X0 Y0 ;
G43 Z10. H01 M3 S100 ;
G01 Z-5. F5000 ;
G42 X10. Y-20. D10 ;
Y-35. ;
G02 X-10. Y-35. R10. ;

)^
S 0 T0000
EDIT **** ** ** 14:43:04
```



The indicated
command is deleted.

B. Deleting a block



1. When a block will be deleted, move the cursor to the beginning of this block.
2. Press the end of block key .
3. Press the delete key , that command is deleted immediately.

Example : Delete the block of G03 X120, Y100, R10. ;

```
PROGRAM O3400 N00000
Y-35. ;
G02 X-10. Y-35. R10. ;
G01 Y-20. ;
G03 X-20. Y-10. R10. ;
G01 X-35. ;
G02 X-35. Y10. R10. ;
G01 X-20. ;
G03 X-10. Y20. R10. ;
G01 Y35. ;
):~
S 0 T0000
EDIT **** **
```



The block to
be deleted.

- (1) Press the end of block key .
- (2) Press the delete key  to delete that command immediately

```
PROGRAM O3400 N00000
Y-35. ;
G02 X-10. Y-35. R10. ;
G01 Y-20. ;
G01 X-35. ;
G02 X-35. Y10. R10. ;
G01 X-20. ;
G03 X-10. Y20. R10. ;
G01 Y35. ;
G02 X10. Y35. R10. ;
):~
S 0 T0000
EDIT **** **
```



The indicated
block is deleted.

C. Deleting multiple blocks :

1. When several continuous blocks will be deleted, move the cursor to the beginning of the first block.
2. Press the MDI key **N,** Enter the block number of the last block.
3. Press the delete key **DELETE** to delete those blocks.

Example : Deleting blocks from N10 to N20.

```

PROGRAM                                00001 N00010
G90 G54 X0 Y0 ;
N10 (12 D12) ;
G43 Z30. H1 S1200 M3 ;
G1 Z-25. F100. M08 ;
G0 Z10. ;
N20 ;
G0 X00.132 Y0 ;
G01 Z-10. ;
X73.036 Y-2.707 ;

)N20"
S 0 T0000
EDIT **** ** * 16:34:06

```

→ These blocks to be deleted.

(1) Press the MDI key **N,** **2↓** **0**.

(2) Press the delete key **DELETE** to delete those blocks.

```

PROGRAM                                00001 N00000
G90 G54 X0 Y0 ;
G0 X00.132 Y0 ;
G01 Z-10. ;
X73.036 Y-2.707 ;
G2 X14.569 Y-19.524 I-43.737 J11.406
F300. ;
G3 X5.402 Y-26.496 I33.565 J-53.644 ;
G2 X-5.402 Y-26.496 I-5.402 J5.9 ;
G3 X-14.569 Y-19.524 I-42.732 J-46.672 ;

) "
S 0 T0000
EDIT **** ** * 16:37:35

```

→ The indicated blocks are deleted.

EXTENDED PART PROGRAM EDITING FUNCTION



There are following capabilities for the extended part program editing function.

1. All or part of a program can be copied to another program.
2. Part of a program can be moved to another program.
3. A program can be merged into other programs.
4. Replace specified words or addresses in the program.

11. Copy Program**Copying an Entire Program**

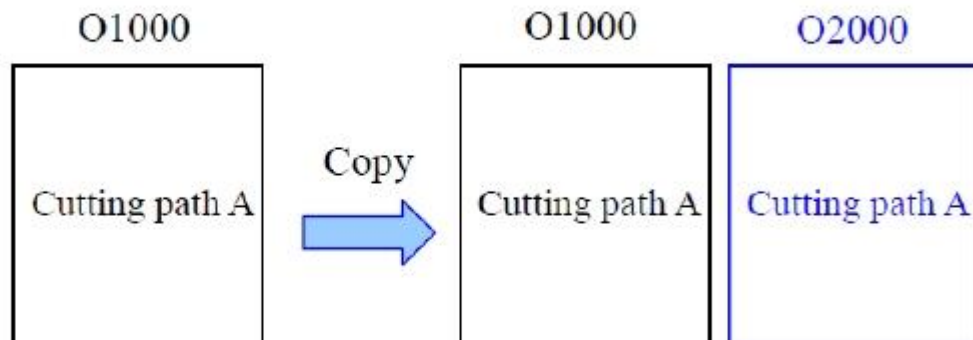
Copy a program as a new program with the same contents.



1. Under the EDIT mode, press the function key .
2. Press the soft key [(OPRT)].
3. Press the rightmost soft key  (continuous menu key).
4. Press the soft key [EX-EDT].
5. Press the soft key [COPY].
6. Press the soft key [ALL].
7. Enter a new program number (without address " O ").

Without specifying a new program number, the program number O0000 is entered automatically.

8. Press the input key .

9. Press the soft key [EXEC]

Copying Part of a Program

Copy part of a program to create a new program.

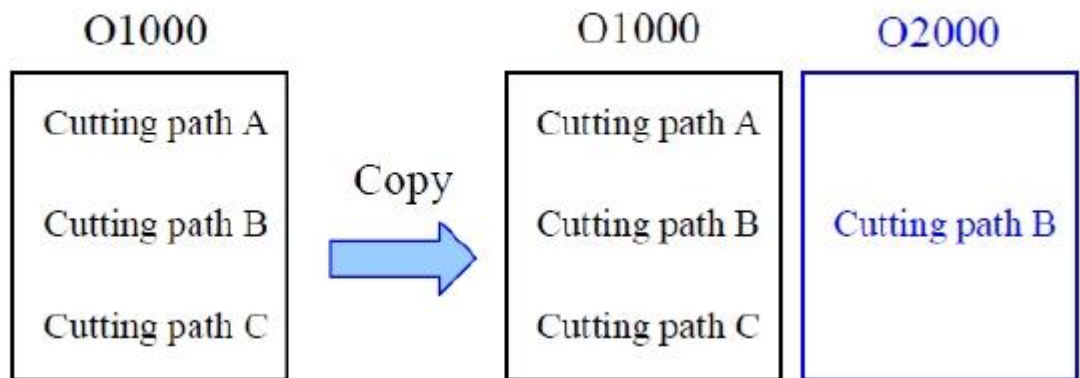

1. Under the EDIT mode, press the function key .

2. Press the soft key [(OPRT)].

3. Press the rightmost soft key  (continuous menu key).

4. Press the soft key [EX-EDT].

5. Press the soft key [COPY].

6. Move the cursor to the start of the range to be copied and press the soft key [CRSL ~].

7. Move the cursor to the end of the range to be copied and press the soft key [~ CRSL].

Or, Press the soft key [~ BTTM] if the copied range is to the end of the program.

8. Enter a new program number (without address “ O ”).

Without specifying a new program number, the program number O0000 is entered automatically.



9. Press the input key .

10. Press the soft key [EXEC].
11. Enter other blocks to complete the new program.

Moving Part of a Program

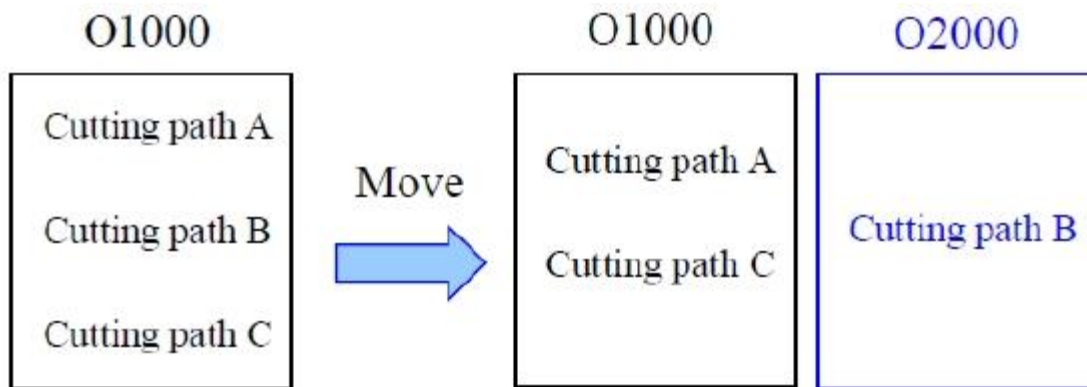
Move part of a program to create a new program and this part is deleted from the original program.



1. Under the EDIT mode, press the function key .
 2. Press the soft key [(OPRT)].
 3. Press the the rightmost soft key  (continuous menu key).
 4. Press the soft key [EX-EDT].
 5. Press the soft key [MOVE].
 6. Move the cursor to the beginning of the range to be moved and press the soft key [CRSL ~].
 7. Move the cursor to the end of the range to be moved and press the soft key [~ CRSL].
- Or, Press the soft key [~ BTTM] if the moved range is to the end of the program.

8. Enter a new program number (without address " O ").

Without specifying a new program number, the program number O0000 is entered automatically.

9. Press the input key .

10. Press the soft key [EXEC].

11. Enter other blocks to complete the new program.

Merging a Program

Copy another program and insert it into the current program at a arbitrary position.

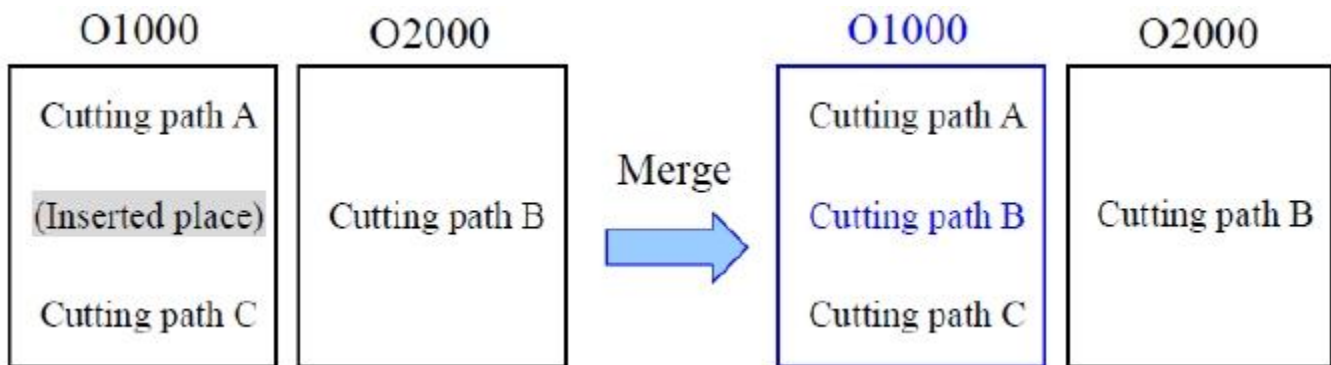

1. Under the EDIT mode, press the function key .

2. Press the soft key [(OPRT)].

3. Press the rightmost soft key  (continuous menu key).

4. Press the soft key [EX-EDT].

5. Press the soft key [MERGE].



6. Move the cursor to the position where will be inserted with another program and press the soft key [~ CRSL].

Or, Press the soft key [~ BTM] for being inserted at the end of the program.

7. Enter the program number (without address " O ") which will be copied.
8. Press the input key .
9. Press the soft key [EXEC].
10. Modify the inserted part to correct program.

Replacement Of Words And Address

Replace specified words or addresses in the program.

1. Under the EDIT mode, press the function key .
2. Press the soft key [(OPRT)].
3. Press the rightmost soft key  (continuous menu key).
4. Press the soft key [EX-EDT].
5. Press the soft key [CHANGE].
6. Enter the words or addresses. (Up to 15 characters can be specified for words.)
7. Press the soft key [BEFORE].
8. Enter the new words or addresses. (Up to 15 characters can be specified for words.)
9. Press the soft key [AFTER].

The cursor is moved to the first place and ready for replacement.

10. Press the soft key [EXEC] to replace all the specified words or addresses.

Or, press the soft key [EX-SGL] once to do single replacement at the place with cursor and search for the next place. Repeat pressing this soft key to continue the other replacement.

Or, press the soft key [SKIP] for no replacement at the searched place with cursor and doing the next search for continuing the next replacement.

Example : Replace all Z-12. with Z-14.

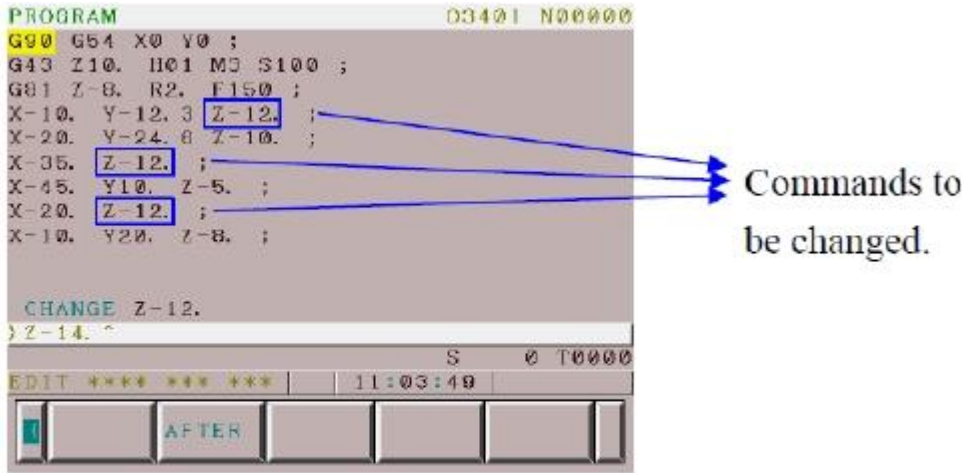

(1) Press the MDI keys **Z_w** **-** **1[↙]** **2[↘]** **.**

(2) Press the soft key [BEFORE].

(3) Press the MDI keys **Z_w** **-** **1[↙]** **4[←]** **.**

(4) Press the soft key [AFTER].

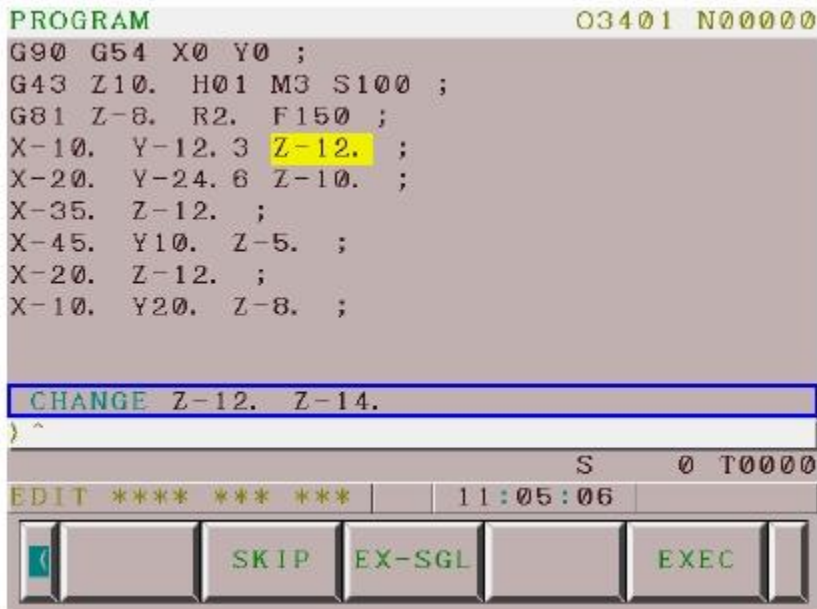

(5) Press the soft key [EXEC].

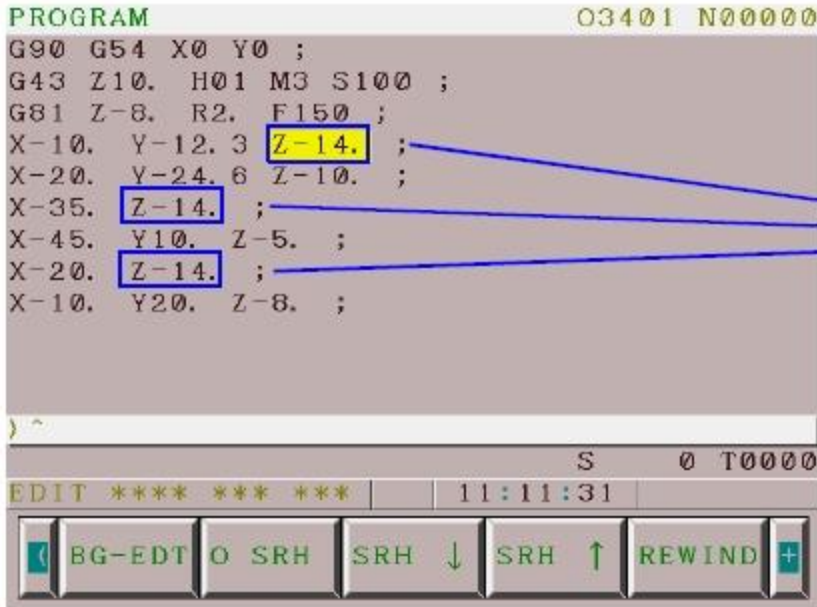

Replacement completed.

Note : The command must be entered completely.

12. GRAPHICS FUNCTION



Graphic Display

When a program is executed, the path of the tool center will be graphed on the screen with the coordinate values in the program.

Parameter setting :

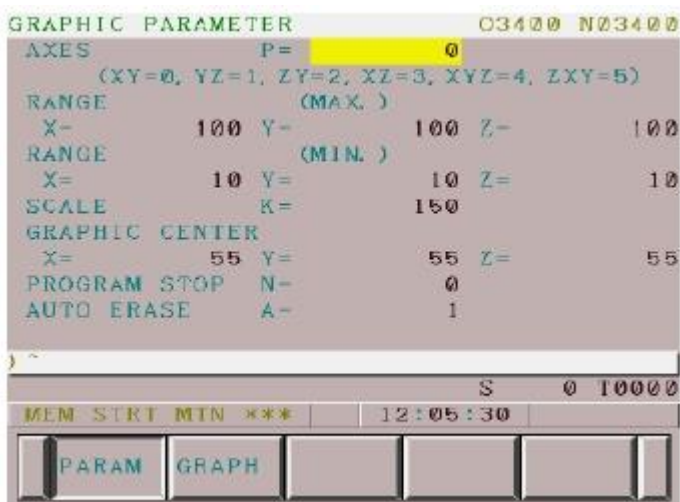
1. Under the MEM mode , press the function key GRAPH .



2. Move the cursor to a parameter by pressing cursor keys  .

(1) AXES (P)

Specify the plane to be used for graphing (valid range 0 to 5).

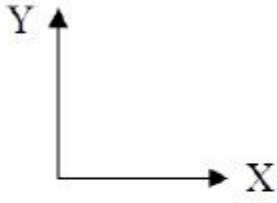
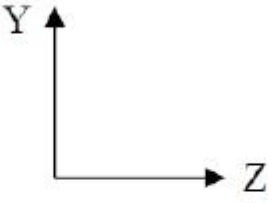
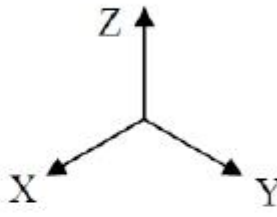
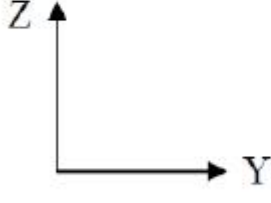
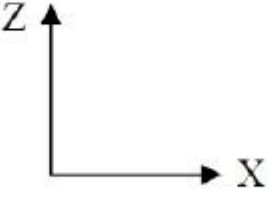
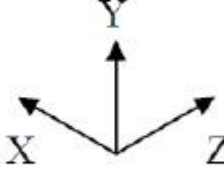
<p>P = 0</p> 	<p>P = 2</p> 	<p>P = 4</p> 
<p>P = 1</p> 	<p>P = 3</p> 	<p>P = 5</p> 

(2) RANGE MAX. / MIN. (X, Y, Z)

Set the graphic range displayed on the screen (valid range 0 to ± 9999999).

(3) SCALE (K)

Set the graphic magnification (valid range 0 to 10000, unit : 0.01 time).

(4) GRAPHIC CENTER (X, Y, Z)

Set the graphic center with the coordinate values on the workpiece coordinate system.

These values will be set automatically.

(5) PROGRAM STOP (N)

Graphing is stopped at the block with the specified sequence number.

This value is automatically cancelled and set as -1 once graphing is finished execution.

(6) AUTO ERASE (A)

Set whether the last graph is cleared or not when entering the graphic function.

Setting value	Meaning
0	Not erase automatically.
1	Erase automatically.

3. Enter the new value and then press the input key  .

Operating method :

1. Under the EDIT mode, press the function key  .

2. Enter the program number to be called.

3. Press the soft key [O SRH].

4. Under the MEM mode, press the cycle start key  to execute the program.

5. Press the function key  .

6. Press the soft key [GRAPH] to start graphing.



→ The coordinate values vary by following the program value executed.

—— Cutting feed

--- Rapid traverse

7. When the graph will be cleared, press the soft key [(OPRT)] and then [ERASE].

Dynamic Graphics Display

The path of the tool center are graphed on the screen as two kind of simulating graph.

Path graph : Show the cutting path of the tool.



Solid graph : Show the solid shape after cutting.

Path Graph

Parameter setting :

- Under the MEM mode , press the function key  .
(display the " PATH GRAPHIC " screen).

Press the page change key  to show the next page for setting.

- Press the cursor keys   to move the cursor to the position for setting change.

(1) AXES (P)

Specify the plane to be used for graphing (valid range 0 to 6).

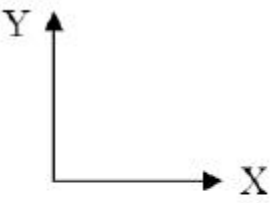
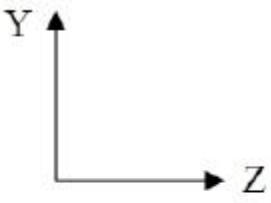
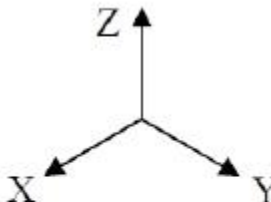
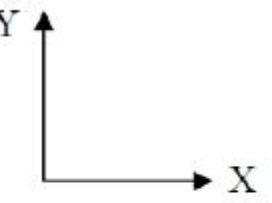
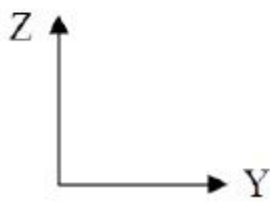
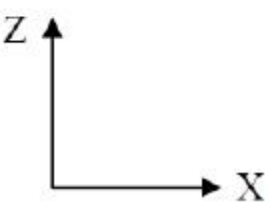
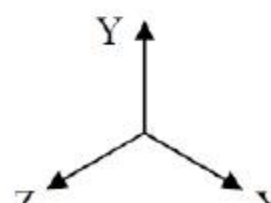
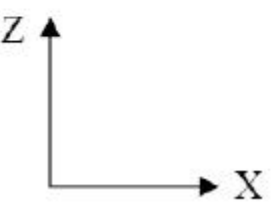
<p>P = 0</p> 	<p>P = 2</p> 	<p>P = 4</p> 	<p>P = 6</p> 
<p>P = 1</p> 	<p>P = 3</p> 	<p>P = 5</p> 	<p>-----</p> 

(2) ANGLE (A)

ROTATION : Rotate the graph horizontally. The value is positive for rotating CW (clockwise) and negative for CCW (counter clockwise).
(valid range -180° to $+180^{\circ}$)

TILTING : Rotate the graph vertically. (valid range -90° to $+90^{\circ}$).

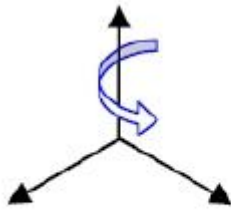

ROTATION

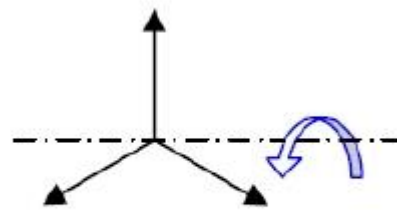

TILTING

(3) SCALE (K)

Set the magnifying rate of graph (valid range 0.01 to 100, unit : 0.01 time).

Setting value	Magnifying rate
0	Graph according to the actual dimension.
1	Set the magnifying rate automatically according to the max. and min. coordinate values of the graph.

(4) CENTER OR MAX./MIN. (X, Y, Z)

Set the center of the graph and setting range.

Setting of SCALE	Setting value	
	X, Y, Z	I, J, K
0	The max. coordinate value	The min. coordinate value
$\neq 0$	Coordinate value of the center of graph	None

(5) START SEQ. NO. (N)

Start graphing from the specified sequence number.

When the setting is 0, start graphing from the beginning of the program.

(6) END SEQ. NO. (N)

Stop graphing at the specified sequence number.

When the setting is 0, graph till the end of the program.

(7) TOOL COMP. (P)

Tool compensation (offset of tool length and diameter) whether they are considered in calculation or not.

Setting value	Tool compensation
0	Calculation considering tool compensation. (Graph shows the actual tool path.)
1	Calculation not considering tool compensation. (Graph shows the program path.)

(8) COLOR (0 1 2 3 4 5 6)

PATH (P) : Specify the color of the tool path.

TOOL (Q) : Specify the color of the current position as the mark of tool.

Setting value	Color
0	White
1	Red
2	Green
3	Yellow
4	Blue
5	Purple
6	Light blue

AUTO CHANGE (R) : Color of tool path whether it is changed or not after automatic tool change.

When the setting value is 1, the value of color setting will be added 1 (+1) automatically after automatic tool change so that color of tool path is changed.

If the setting value exceeds 6, it returns 0.

Setting value	color of the tool path
0	Not changed
1	Changed automatically

3. Enter the new value and then press the input key .

Operating method :

1. Under the EDIT mode, press the function key .

2. Enter the program number to be called.

3. Press the soft key [O SRH].

4. Under the MEM mode, press the function key .
(Display the " PATH GRAPHIC " screen.)

5. Press the soft key [EXEC].

6. Press the soft key [(OPRT)].

7. There are two executing manners as follows.

(1) Executing all : Press the soft key [AUTO].

(2) Single block : Press the single block button  on the machine operating panel, then the soft key [START]. For pressing the soft key [START] once, a block is executed.

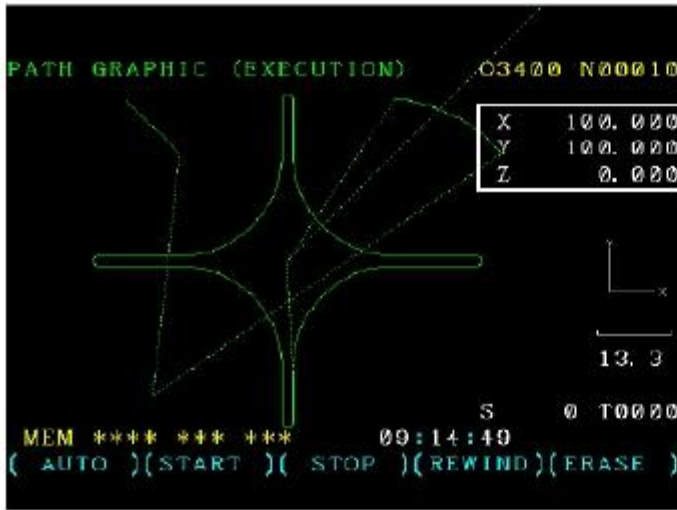

The coordinate values vary by following the program value executed. If there is no display of coordinate, set the par. No. 6500 # 5 = 0.

- Cutting feed
- Rapid traverse

8. Press the soft key [STOP] to stop graphing.
9. Press the soft key [REWIND] to repeat display.
10. Press the soft key [ERASE] to clear the graph.
11. If the graph will be magnified or contracted with a specified magnifying rate, press the soft key [SCALE].
12. Press the soft key [(OPRT)].
13. Press the soft key [←] [→] [↑] [↓] to move the cursor to the place for being magnified or contracted.
14. Press the Address keys **P_c** **M_#** to do magnification or contraction.

Address key	Scale
P	Increase 0.1
M	Decrease 0.1

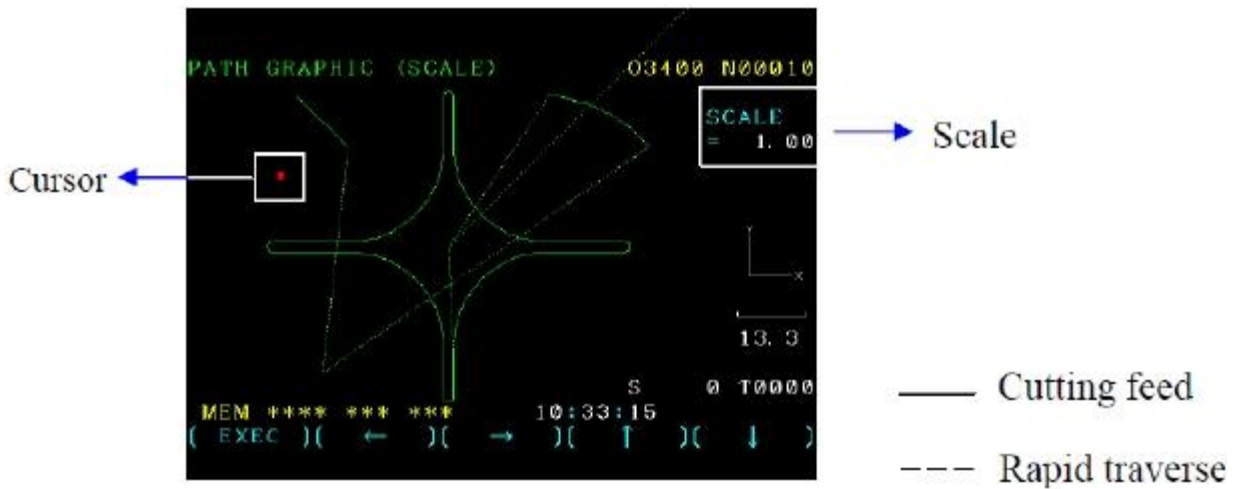

Dynamic Graphics Display

Parameter setting

1. Press the function key GRAPH (display the "SOLID GRAPHIC" screen).

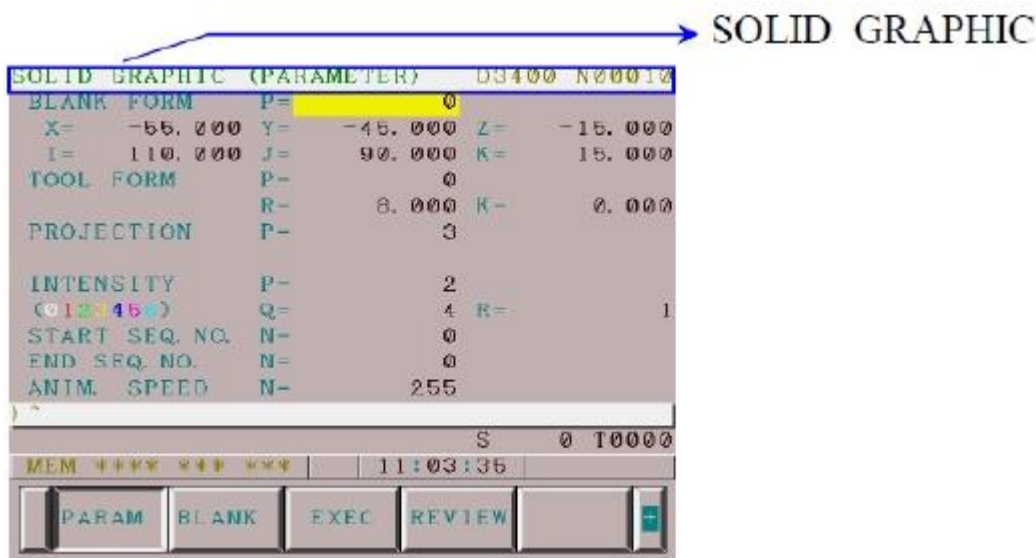

2. Press the cursor keys ↑ ↓ to move the cursor to the place for being modified.

(1) BLANK FORM (P, X, Y, Z, I, J, K)

Set the type of blank figure under P.

P	Blank figure
0	Rectangular
1	Column
2	Hollow cylinder

X, Y, Z values are the coordinate value at the left lower corner of the work material relative to the work origin.

Set the dimensions of materials under I, J, K.

Material	I	J	K
Rectangular	Length along X-axis	Length along Y-axis	Length along Z-axis
Column	Radius	0	Length of column
Hollow cylinder	Outside radius	Inside radius	Length of cylinder

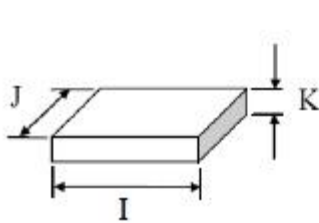

P = 0

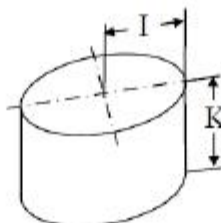

P = 1

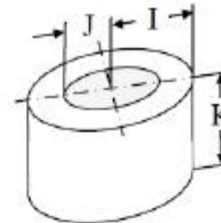

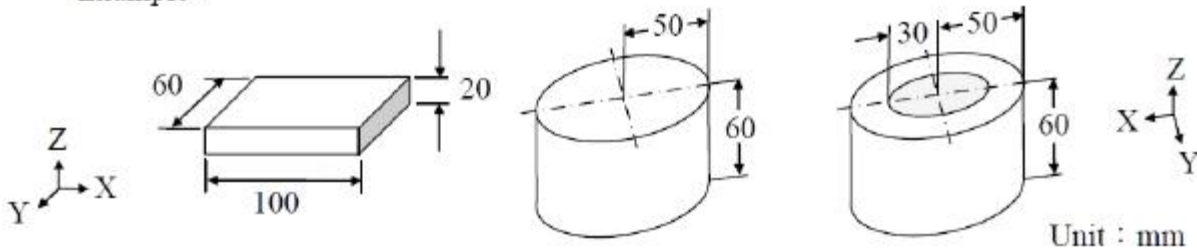

P = 2

Example :

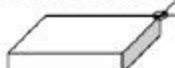

Unit : mm

P = 0	X	Y	Z	I	J	K
The work origin is at the left front corner. 	0	0	-20	100	60	20
The work origin is at the center. 	-50	-30	-20	100	60	20
The work origin is at the right rear corner. 	-100	-60	-20	100	60	20

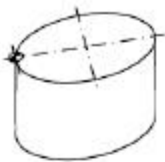
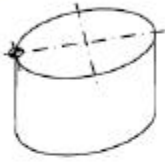
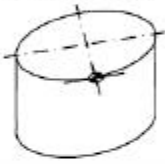
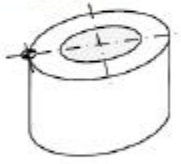
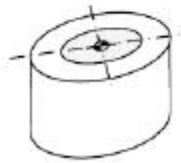
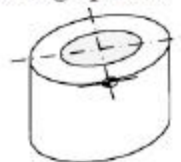
P = 1	X	Y	Z	I	J	K
<p>The work origin is at the left edge point.</p> 	50	0	-60	50	0	60
<p>The work origin is at the center.</p> 	0	0	-10	100	0	60
<p>The work origin is at the front edge point.</p> 	0	-50	-10	100	0	60
P = 2	X	Y	Z	I	J	K
<p>The work origin is at the left edge point.</p> 	50	0	-60	50	30	60
<p>The work origin is at the center.</p> 	0	0	-10	100	30	60
<p>The work origin is at the front edge point.</p> 	0	-50	-10	100	30	60

(2) TOOL FORM (P, R, K)

Set the machining direction of tools under P.

P	Machining direction of tools
0, 1	Parallel to the Z axis (start machining along the positive direction)
2	Parallel to the X axis (start machining along the positive direction)
3	Parallel to the Y axis (start machining along the positive direction)
4	Parallel to the Z axis (start machining along the negative direction)
5	Parallel to the X axis (start machining along the negative direction)
6	Parallel to the Y axis (start machining along the negative direction)

Set the dimensions of a tool under R, K.

(The tool shape is preset such as the END MILL.)

R	Radius of the tool
K	Distance from the program point to tool tip

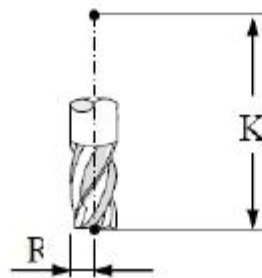

(3) PROJECTION (P)

Setting of the graphing view angle

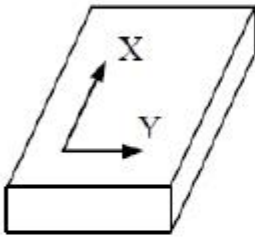
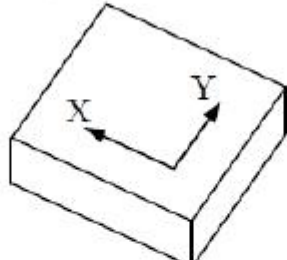
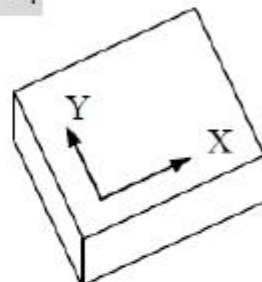
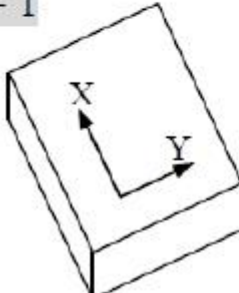
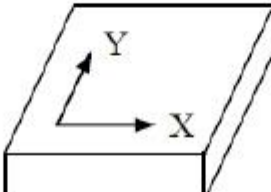
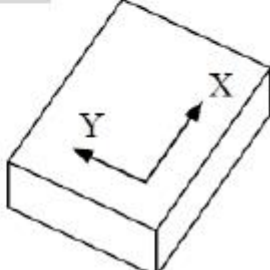
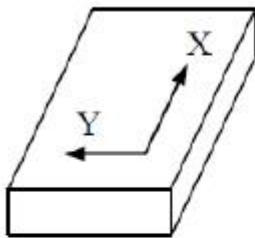
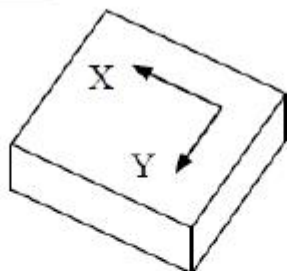
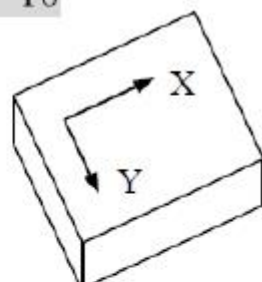
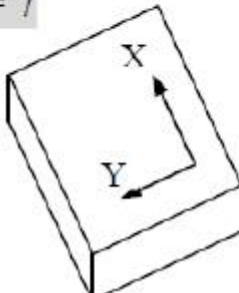
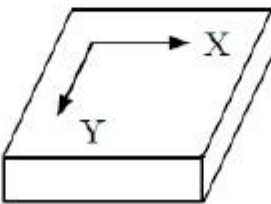
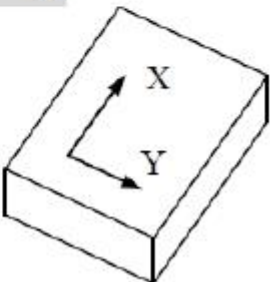
<p>P = 0</p> 	<p>P = 2</p> 	<p>P = 4</p> 
<p>P = 1</p> 	<p>P = 3</p> 	<p>P = 5</p> 
<p>P = 6</p> 	<p>P = 8</p> 	<p>P = 10</p> 
<p>P = 7</p> 	<p>P = 9</p> 	<p>P = 11</p> 

(4) INTENSITY (0 1 2 3 4 5 6) (P, Q, R)

Setting of color.

Setting value	Color
0	White
1	Red
2	Green
3	Yellow
4	Blue
5	Purple
6	Light blue

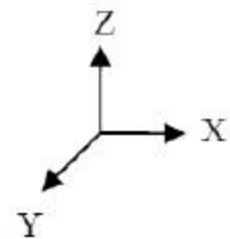
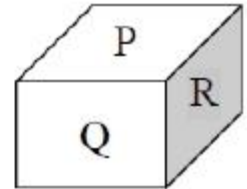
**(5) START SEQ. NO. (N)**

Start graphing from the specified sequence number.

When the setting is 0, start graphing from the beginning of the program

(6) END SEQ. NO. (N)

Stop graphing at the specified sequence number.

When the setting is 0, graph till the end of the program.

(7) ANIM SPEED (N)

Specify the graphing speed (valid range 0 to 255).

3. Enter the new value for replacement and then press the input key .

Operating method :

1. Having set the relative parameter, press the soft key [BLANK] to check the shape of the raw material.
2. Press the soft key [(OPRT)].

3. Press the soft key [+ ROT] [- ROT] to adjust the view angle of the raw material.

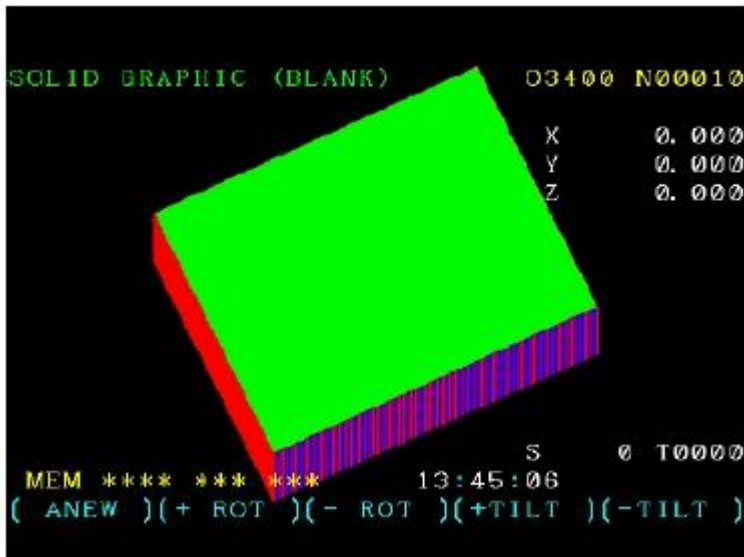

During adjusting the view angle, the parameter PROJECTION of view angle will be changed simultaneously.

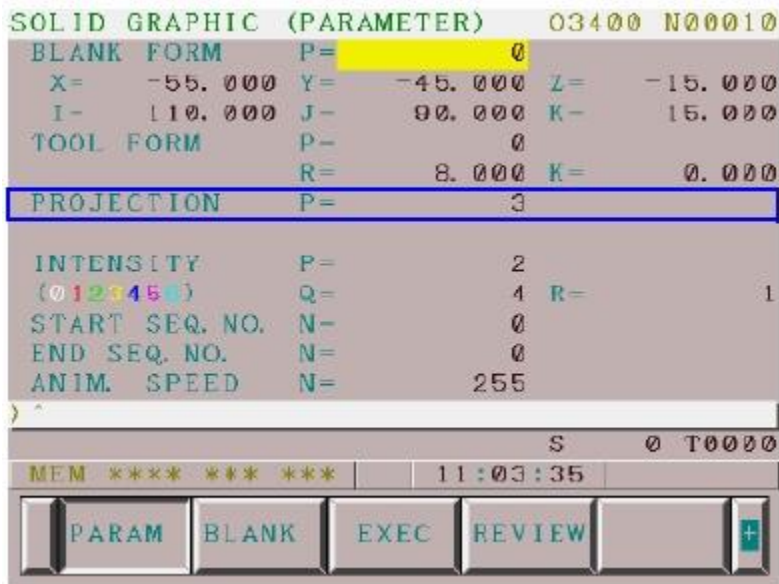

4. Press the soft key [+ TILT] to show the display as the above.

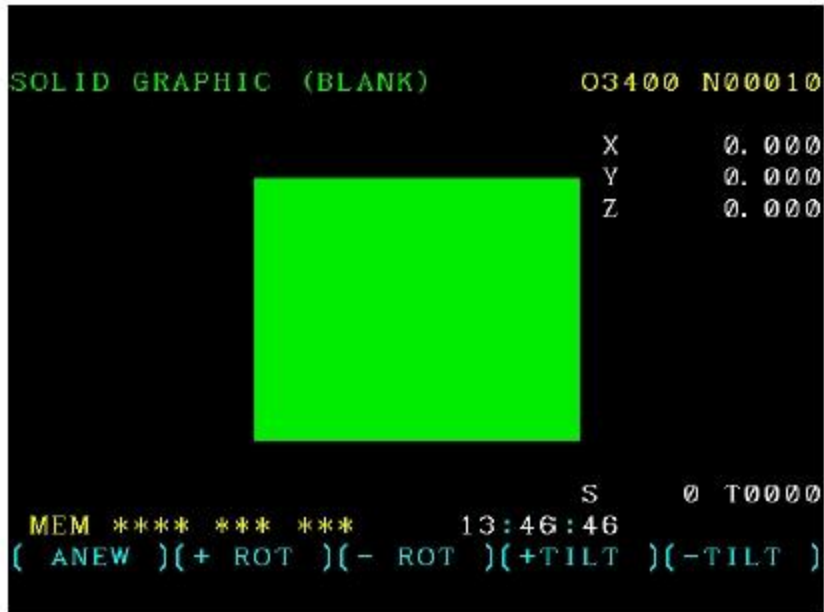

Press the soft key [- TILT] to return the display of graph.

5. Press the soft key [ANEW] to start a new display.

Operating method :

1. Under the EDIT mode, press function key .

2. Enter a program number.

3. Press the soft key [O SRH].

4. Under the MEM mode, press function key .

(display the “ SOLID GRAPHIC ” screen).

5. Press the soft key [EXEC].

6. Press the soft key [(OPRT)].

7. There are two executing methods as follows.

(1) Executing all : Press the soft key [A . ST].

(2) Executing single block : Press the single block key  on the operating panel, then press soft key [F . ST]. For pressing the [F . ST] once, a block is executed.

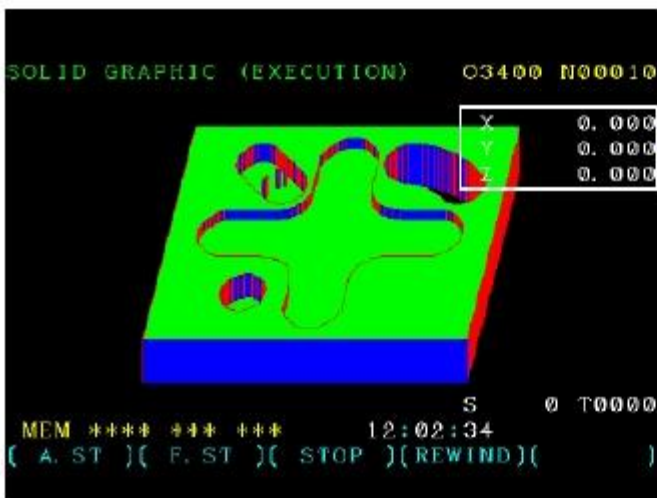

The coordinate values vary by following the program value executed. If there is no display of coordinate, set the par. No. 6500 # 5 = 0.

8. Press the soft key [STOP] to stop graphing.

9. Press the soft key [REWIND] to start a new display.

Note : Helical interpolation cannot be graphed in solid graphics.

Tri-plane view :

1. Press the rightmost soft key  (continuous menu key).

2. Press the soft key [3-PLN].

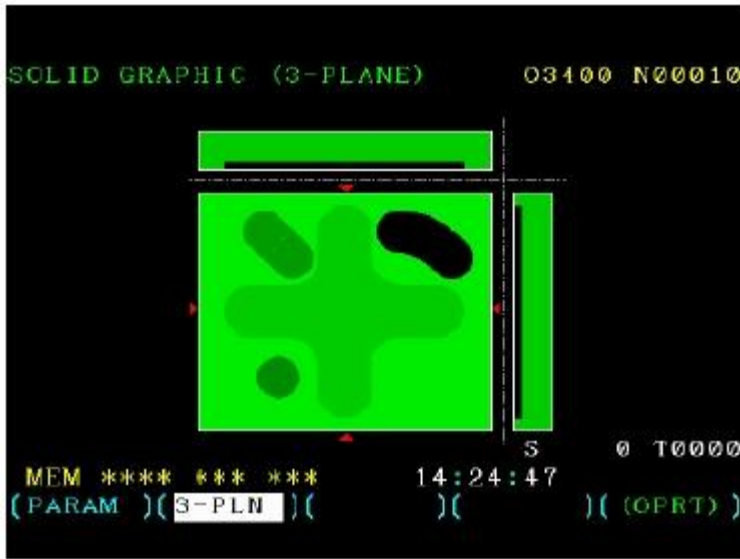

3. Press the soft key [(OPRT)] to change the display of side-view drawings.
4. Press the soft key [↻] to shift the view angle of the drawing.
5. Press the soft key [←] [→] [↑] [↓] to move the mark of secting position.

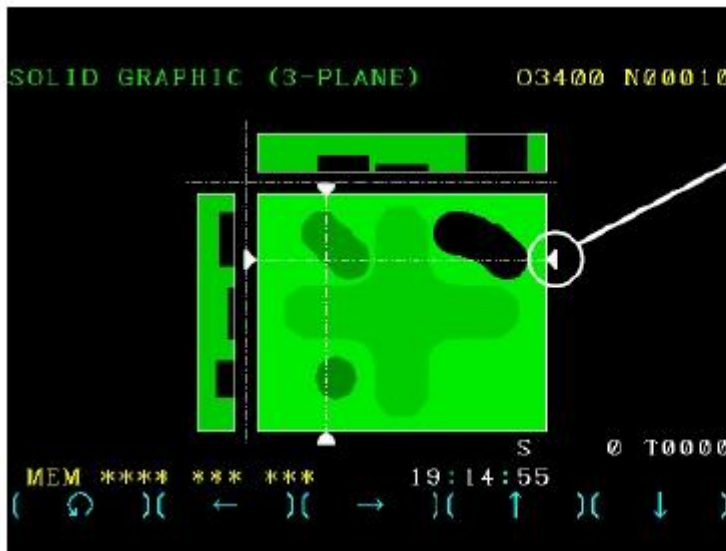

Example :

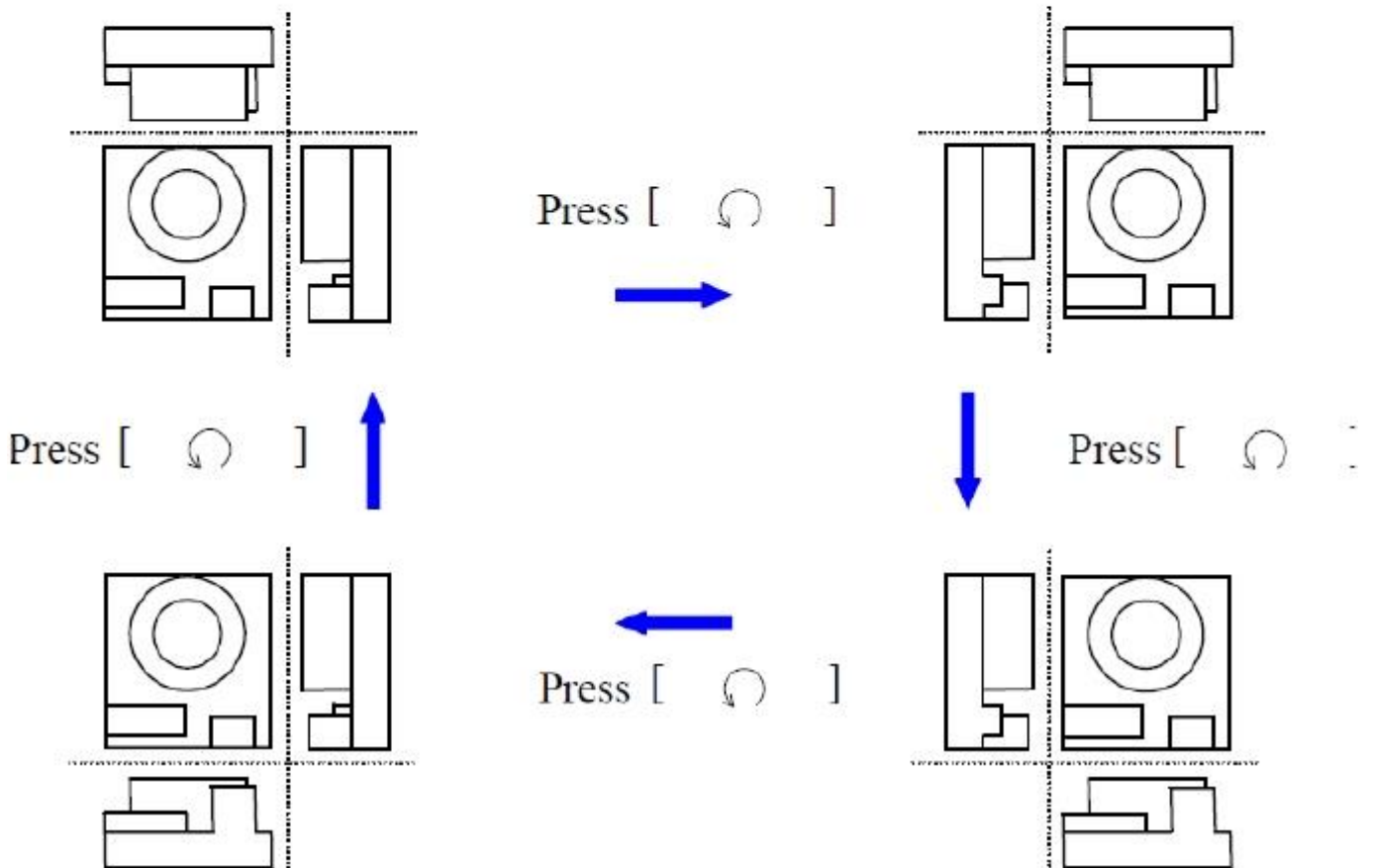
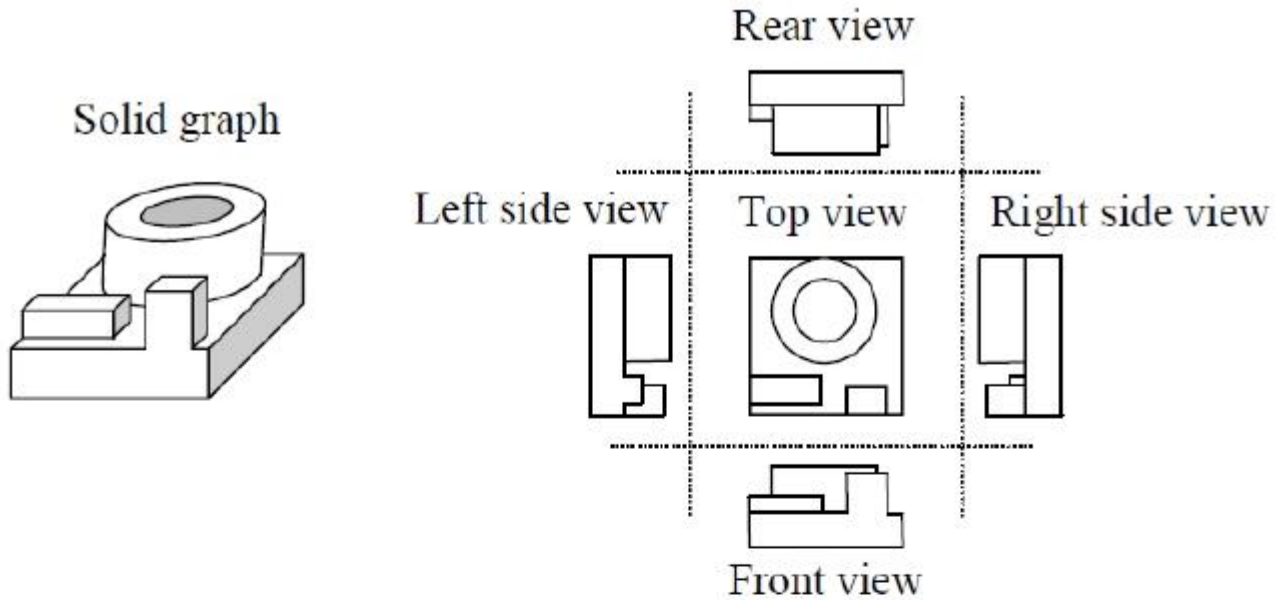

Chapter 4

Program Cutting Commanded Description

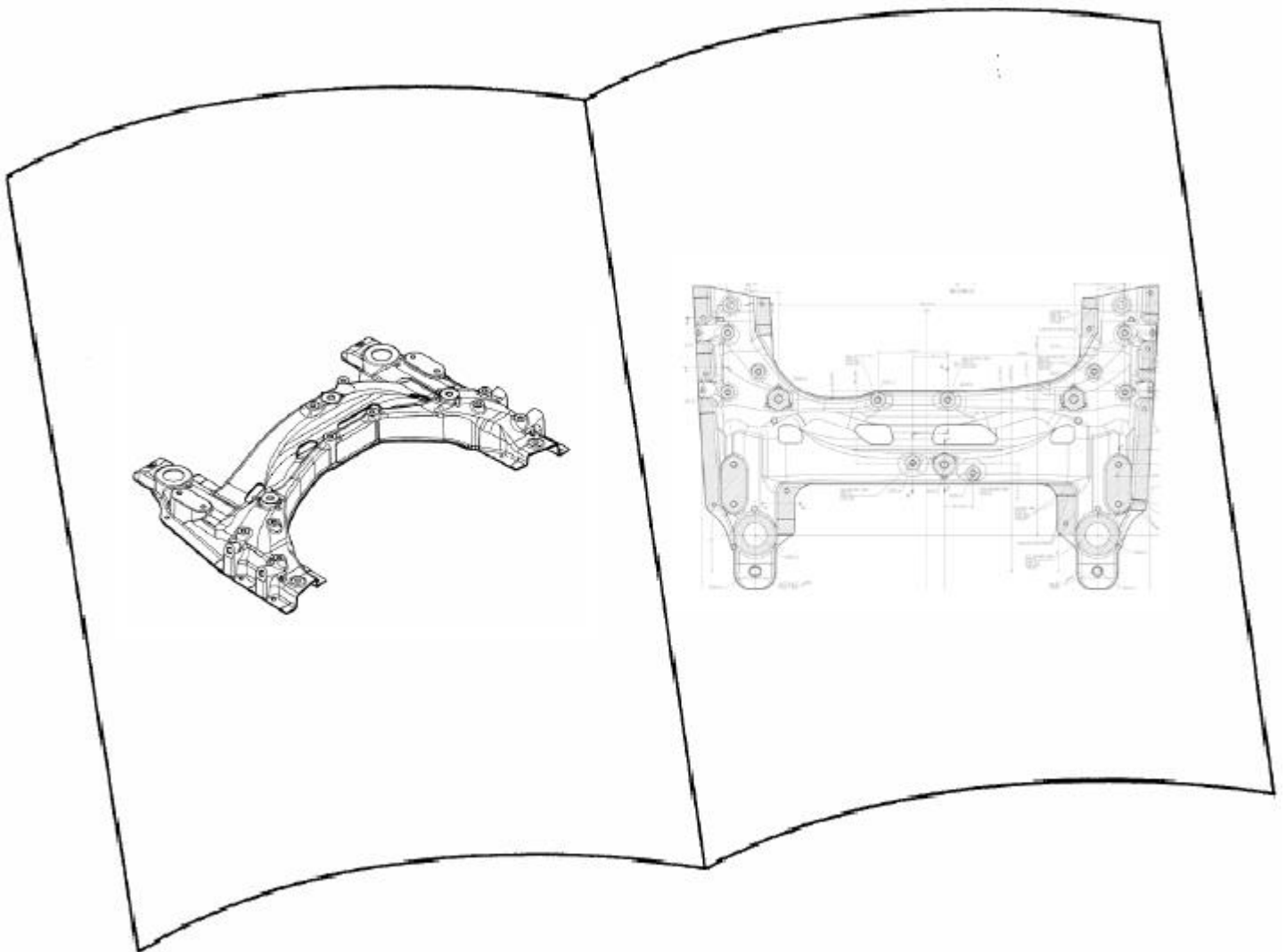

1. Description About All Functions

1.1 G Function

G functions are also called as preparation functions. They are designed completely inside the controller. Different G codes give different meaning and action.

G codes are divided into two types as follows :

1. One – shot G code

Such a G code is effective only in the block in which it is specified.

It is ineffective in other blocks.

Example : G04, G09, G28, etc.

2. Modal G code

Such a G code is effective until another G code of the same group is specified.

(Please refer to the G code list for groups of G codes)

Example :

```
G00 Z30. ;  
      :  
X20. Y20. ;
```

} G00 is effective in this range.

G01 Z-5. F200 ; → G01 replaces G00.

Note : (1) In the G code list, the group 00 are those of one-shot G codes. The other groups are all of modal G codes.

(2) If different G codes of the same group are used in a block simultaneously, the last one is the effective one.

Example : G00 G01 X__ Y__ ;

Explain

1. When the clear state (parameter CLR (No. 3402#6)) is set at power-up or reset, the modal G codes are placed in the states described below.
 - (1) The modal G codes are placed in the states marked with  as indicated in Table 2.
 - (2) G20 and G21 remain unchanged when the clear state is set at power-up or reset.
 - (3) Which status G22 or G23 at power on is set by parameter G23 (No. 3402#7). However, G22 and G23 remain unchanged when the clear state is set at reset.
 - (4) The user can select G00 or G01 by setting parameter G01 (No. 3402#0).
 - (5) The user can select G90 or G91 by setting parameter G91 (No. 3402#3).
When G code system B or C is used in the lathe system, setting parameter G91 (No. 3402#3) determines which code, either G90 or G91, is effective.
 - (6) In the machining center system, the user can select G17, G18, or G19 by setting parameters G18 and G19 (No. 3402#1 and #2).
2. G codes in group 00 other than G10 and G11 are one-shot G codes.
3. When a G code not listed in the G code list is specified, or a G code that has no corresponding option is specified, alarm PS0010 occurs.
4. Multiple G codes can be specified in the same block if each G code belongs to a different group. If multiple G codes that belong to the same group are specified in the same block, only the last G code specified is valid.
5. If a G code belonging to group 01 is specified in a canned cycle for drilling, the canned cycle for drilling is cancelled. This means that the same state set by specifying G80 is set. Note that the G codes in group 01 are not affected by a G code specifying a canned cycle for drilling.
6. G codes are indicated by group.
7. The group of G60 is switched according to the setting of the parameter MDL (No. 5431#0). (When the MDL bit is set to 0, the 00 group is selected. When the MDL bit is set to 1, the 01 group is selected.)

Table 1.1 G Code List

G code	Group	Function		
G00	01	Positioning		
G01		Linear interpolation		
G02		Circular interpolation/Helical interpolation CW		
G03		Circular interpolation/Helical interpolation CCW		
G02.2, G03.2		Involute interpolation		
G02.3, G03.3		Exponential interpolation		
G04		00	Dwell, Exact stop	
G05	High speed cycle machining			
G07	Hypothetical axis interpolation			
G07.1 (G107)	Cylindrical interpolation			
G08	Look-ahead control			
G09	Exact stop			
G10	Programmable data input			
G10.6	Tool retract & recover			
G11	Programmable data input mode cancel			
G12.1	25		Polar coordinate interpolation mode	
G13.1			Polar coordinate interpolation cancel mode	
G15	17	Polar coordinates command cancel		
G16		Polar coordinates command		
G17	02	XpYp plane selection	Xp: X axis or its parallel axis	
G18		ZpXp plane selection	Yp: Y axis or its parallel axis	
G19		YpZp plane selection	Zp: Z axis or its parallel axis	
G20	06	Input in inch		
G21		Input in mm		
G22	04	Stored stroke check function on		
G23		Stored stroke check function off		
G25	24	Spindle speed fluctuation detection off		
G26		Spindle speed fluctuation detection on		
G27	00	Reference position return check		
G28		Return to reference position		
G29		Return from reference position		
G30		2nd, 3rd and 4th reference position return		
G30.1		Floating reference point return		
G31		Skip function		
G33		01	Thread cutting	

G code	Group	Function
G37	00	Automatic tool length measurement
G39		Corner offset circular interpolation
G40	07	Cutter compensation cancel/Three dimensional compensation cancel
G41		Cutter compensation left/Three dimensional compensation
G42		Cutter compensation right
G40.1 (G150)	19	Normal direction control cancel mode
G41.1 (G151)		Normal direction control left side on
G42.1 (G152)		Normal direction control right side on
G43	08	Tool length compensation + direction
G44		Tool length compensation – direction
G45	00	Tool offset increase
G46		Tool offset decrease
G47		Tool offset double increase
G48		Tool offset double decrease
G49	08	Tool length compensation cancel
G50	11	Scaling cancel
G51		Scaling
G50.1	22	Programmable mirror image cancel
G51.1		Programmable mirror image
G52	00	Local coordinate system setting
G53		Machine coordinate system selection
G54	14	Workpiece coordinate system 1 selection
G54.1		Additional workpiece coordinate system selection
G55		Workpiece coordinate system 2 selection
G56		Workpiece coordinate system 3 selection
G57		Workpiece coordinate system 4 selection
G58		Workpiece coordinate system 5 selection
G59		Workpiece coordinate system 6 selection
G60	00/01	Single direction positioning
G61	15	Exact stop mode
G62		Automatic corner override
G63		Tapping mode
G64		Cutting mode

G code	Group	Function
G65	00	Macro call
G66	12	Macro modal call
G67		Macro modal call cancel
G68	16	Coordinate rotation/Three dimensional coordinate conversion
G69		Coordinate rotation cancel/Three dimensional coordinate conversion cancel
G72.1	00	Rotation copy
G72.2		Parallel copy
G73	09	Peck drilling cycle
G74		Counter tapping cycle
G75	01	Plunge grinding cycle (for grinding machine)
G76	09	Fine boring cycle
G77	01	Direct constant–dimension plunge grinding cycle(for grinding machine)
G78		Continuous–feed surface grinding cycle(for grinding machine)
G79		Intermittent–feed surface grinding cycle(for grinding machine)
G80	09	Canned cycle cancel/external operation function cancel
G81		Drilling cycle, spot boring cycle or external operation function
G82		Drilling cycle or counter boring cycle
G83		Peck drilling cycle
G84		Tapping cycle
G85		Boring cycle
G86		Boring cycle
G87		Back boring cycle
G88		Boring cycle
G89		Boring cycle
G90		03
G91	Increment command	
G92	00	Setting for work coordinate system or clamp at maximum spindle speed
G92.1		Workpiece coordinate system preset
G94	05	Feed per minute
G95		Feed per rotation
G96	13	Constant surface speed control
G97		Constant surface speed control cancel
G98	10	Return to initial point in canned cycle
G99		Return to R point in canned cycle
G160	20	In–feed control function cancel(for grinding machine)
G161		In–feed control function(for grinding machine)

1.2 F Commanded

The F function is also called as feed function. It is used for speed control of tool movement.

Expression of the value following the F command :

Feed per minute	mm/min (Metric)
	inch/min (Inch)
Feed per rotation	mm/rev (Metric)
	inch/rev (Inch)

If a commanded value of F function is out of the setting range in the machine, the setting value will be the actual feedrate.

Having set the feedrate with F function, if it is not specified again, the previous feedrate is kept effective. For actual requirement in machining, the programmed feedrate can be adjusted with the rotary switch FEEDRATE OVERRIDE % to get the adequate feedrate.

1.3 S Commanded

The S function is also called as spindle speed. Spindle speed is specified with the value following the S command. Its unit is rpm.

If a commanded value of S function is out of the setting range in the machine, the maximum or minimum setting value will be the actual speed.

For actual requirement in machining, the programmed spindle speed can be adjusted with the rotary switch SPINDLE OVERRIDE % to get the adequate speed.

The spindle doesn't rotate by executing the S command only, but rotate also by executing the command of spindle rotation CW (M03) or CCW (M04).

Note : If there is a hi-low speed gearbox, it is possible to shift step of spindle speed when executing the S command .

Formulas about cutting conditions :

1. Spindle speed

$$S = \frac{1000 V}{\pi D}$$

Description :

S : Spindle speed (rpm)

V : Cutting speed (m/min)

π : Ludolphian number (3.14)

D : Tool diameter (mm)

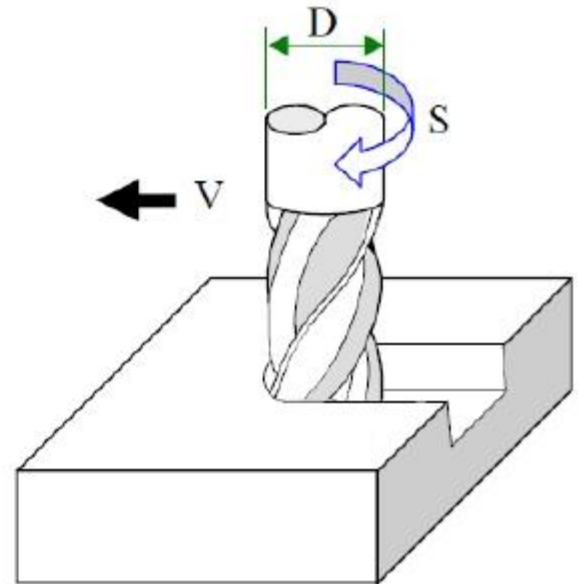

2. Pre-drilling diameter for tapped hole :

$$d = D - P$$

Cutting feedrate :

$$F = P \times S$$

Description :

d : Drill diameter (mm)

D : Thread diameter (mm)

P : Thread pitch (mm)

S : Spindle speed (rpm)

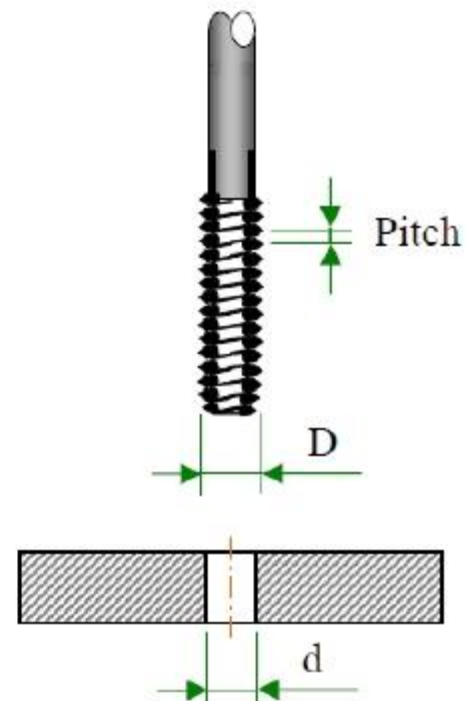

3. Calculation about length of drill tip with standard tip angle of 118° :

$$L = \frac{D}{2\sqrt{3}}$$

$$= 0.3 D$$

Cutting feedrate

$$F = fr \times S$$

Description :

- L : Length of drill tip (mm)
- D : Drill diameter (mm)
- F : Feedrate (mm/min)
- fr : Feed per rotation (mm/rev)
- S : Spindle speed (rpm)



4. Cutting feedrate :

$$F = fz \times t \times S$$

Description :

- F : Feedrate (mm/min)
- fz : Feed per blade (mm/blade)
- t : Blade amount of the tool
- S : Spindle speed (rpm)

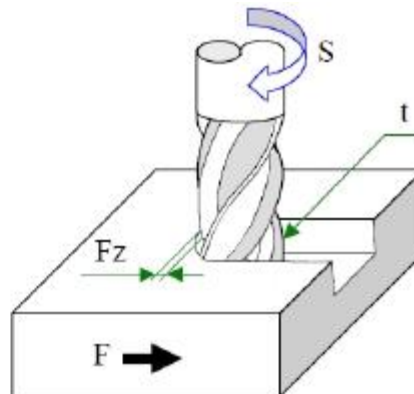

Example :

- Conditions : Tool diameter : ϕ 100 mm (D)
- Cutting speed : 100 m/min (V)
- Ludolphian number : 3.14 (π)
- Feed per blade : 0.1 mm/tooth (fz)
- Blade amount of tool : 5 tooth (t)

$$\text{Spindle speed } S = \frac{1000 V}{\pi D} = \frac{1000 \times 100}{3.14 \times 100}$$

$$= 318 \text{ rpm}$$

$$\text{Cutting feedrate } F = fz \times t \times S = 0.1 \times 5 \times 318 = 159 \text{ mm/min.}$$

$$= 159 \text{ mm/min}$$

1.4 T Function

The T function is also called as tool function. The value following the T command specifies the tool number to be called. When a T code is executed, the called tool moves to the standby position, but no tool change yet.

Note : When different T codes are commanded in the same block, the last one is the effective one.

Example : T01 T02 ; → The command T02 is the effective.

1.5 G Code Use Composition

Positioning (G00)

Use of the command :

It is used for positioning without cutting and with rapid movement. The rapid moving speed for positioning follows the specification of the machine.

Format :

G00 X__ Y__ Z__ ;

Meaning of command :

X, Y, Z : Coordinates of the end position

Example :

Assume the tool is at the current position of (X-15. Y-100.). It will move rapidly to the position of (X-30. Y-30.).

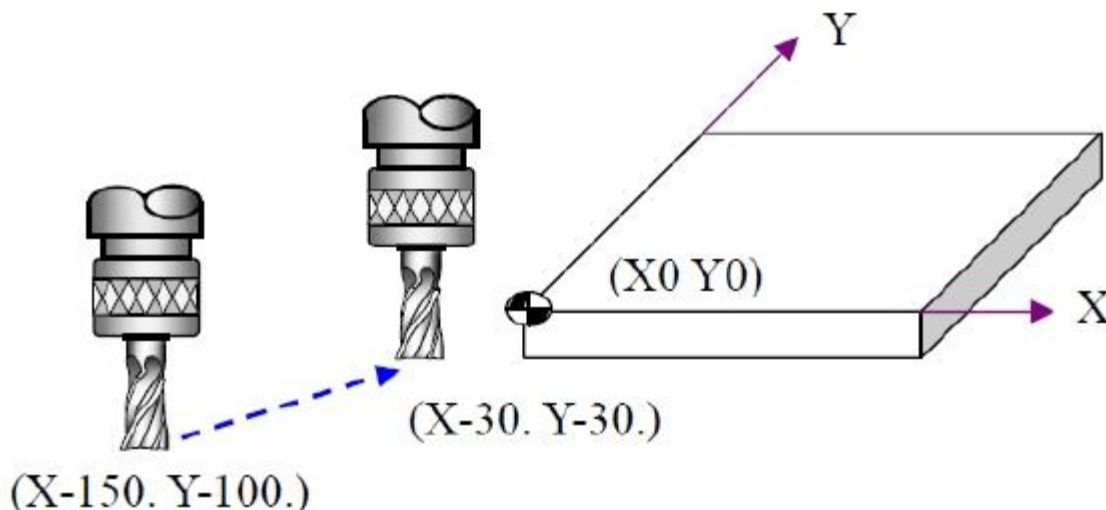

O1000 ;
 G80 G40 G49 G00 G17 ;
 G90 G54 X-150. Y-100. ; → Current position
 G00 X-30. Y-30. ;
 M30 ;

Parameter

No.	Meaning
1401 # 1	Positioning is performed with 0 : non-linear positioning 1 : linear interpolation
1601 # 5	Inposition check at deceleration 0 : performed 1 : not performed

Description on linear and non-linear interpolation.

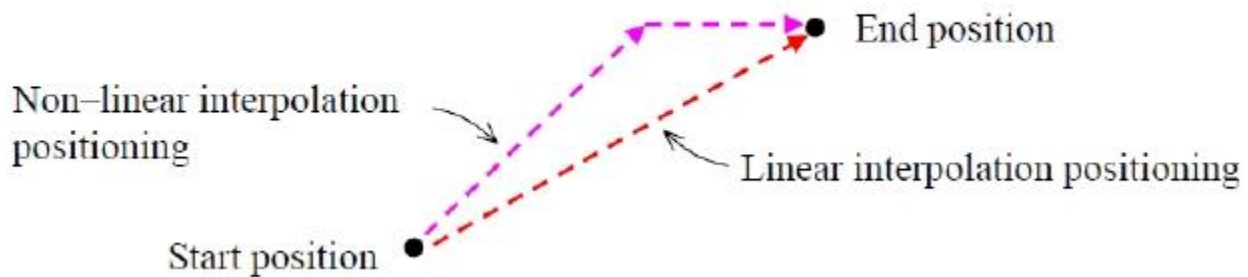

Note: (1) The above example is written with the absolute command G90 (referring to the article of G90 absolute/G91 incremental commands) and without considering the Z axis position.

(2) The moving feedrate of G00 can be adjusted with the rotary switch "RAPID FEEDRATE %" on the operating panel.

Linear Interpolation

Use of the command :

It is used for a straight path with cutting. The moving speed is specified with the F feedrate command.

Format :

G01 X__ Y__ Z__ F__ ;

Meaning of command :

X, Y, Z : Coordinates of the end position

F : Feedrate

Example :

```
O1000 ;
G80 G40 G49 G00 G17 ;
G90 G54 X0 Y0 ;
G43 Z3. H01 M3 S800 ;
G01 Z-5. F80 ;
X50. Y40. F160 ; → Linear interpolation
X150. Y40. ; → Linear interpolation
X150. Y120. ; → Linear interpolation
X50. Y40. ; → Linear interpolation
Z3. ;
G49 G00 Z0 M5 ;
M30 ;
```

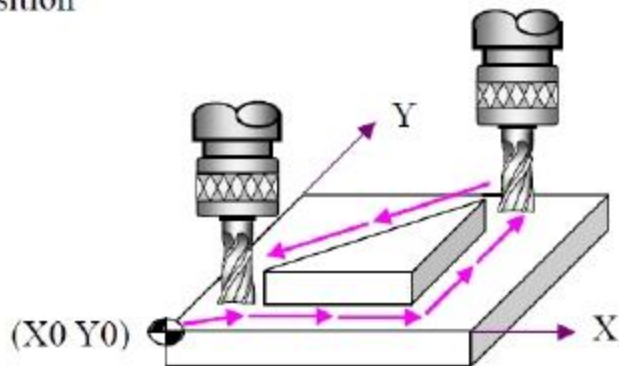

Parameter

No.	Meaning
3402 # 0	Mode entered when the power is turned on 0 : G00 mode (positioning) 1 : G01 mode (linear interpolation)

Note : Because G01 is a modal G code, if there are continuous cutting actions, the command G01 in the latter blocks can be omitted.

Optional Angle Chamfering and Corner Rounding

Use of the command :

It is used for chamfering or corner rounding under the following conditions :

1. A straight line connects another straight line.
2. A straight line connects an arc.
3. An arc connects a straight line.
4. An arc connects another arc.

Format :

```
G01 X__ Y__ , C__ ;
```

```
G01 X__ Y__ , R__ ;
```

Meaning of command :

X, Y : Coordinates of the end position

C : Chamfering value (45°)

R : Rounding radius

Example :

1. Automatic chamfering

```
G91 G01 X100. , C10. ;
```

```
X100. Y100. ;
```

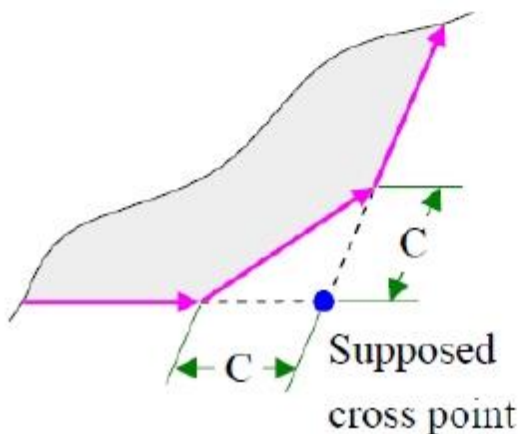

2. Automatic corner rounding

```
G91 G01 X100. , R10. ;
```

```
X100. Y100. ;
```

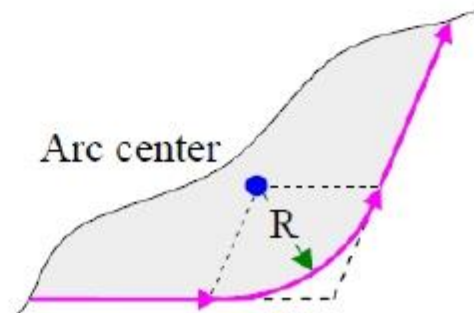

Circular Interpolation (G02 / G03)

Use of the command :

It is used for cutting of normal arc path. The cutting direction can be specified.

Format :

$(X_P - Y_P)$ G17 G02/G03 X__ Y__ R__ F__ ; or
G17 G02/G03 X__ Y__ I__ J__ F__ ;

$(Z_P - X_P)$ G18 G02/G03 Z__ X__ R__ F__ ; or
G18 G02/G03 Z__ X__ I__ K__ F__ ;

$(Y_P - Z_P)$ G19 G02/G03 Y__ Z__ R__ F__ ; or
G19 G02/G03 Y__ Z__ J__ K__ F__ ;

Meaning of command :

X, Y, Z : Coordinates of the end position

I : The vector from the start point of cutting to the arc center along X axis.

J : The vector from the start point of cutting to the arc center along Y axis.

K : The vector from the start point of cutting to the arc center along Z axis.

R : Arc radius

F : Feedrate

Description on I, J, K, R and judgement of the positive or negative value :

1. From the start point to the arc center, the vector values are I along the X axis, J along the Y axis and K along the Z axis.
2. The values of I, J and K are positive when the arc center is located at the positive side along the corresponding axes of the start point and negative when the arc center at the negative side of the start point.

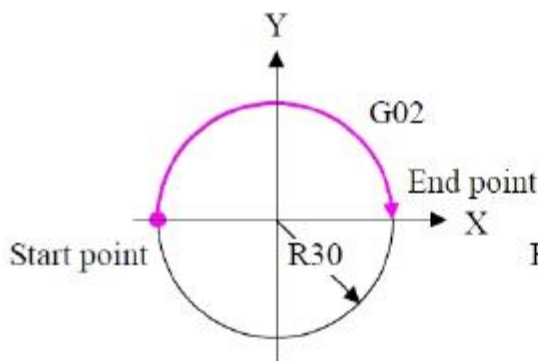

$I = 30, J = 0$

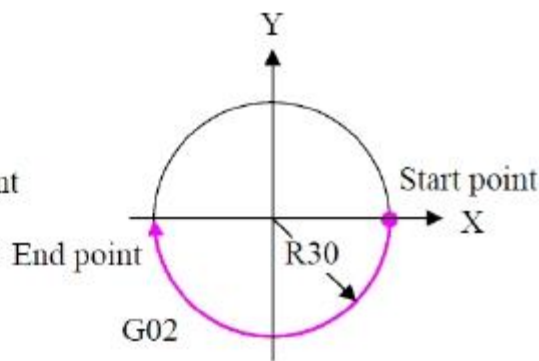

$I = -30, J = 0$

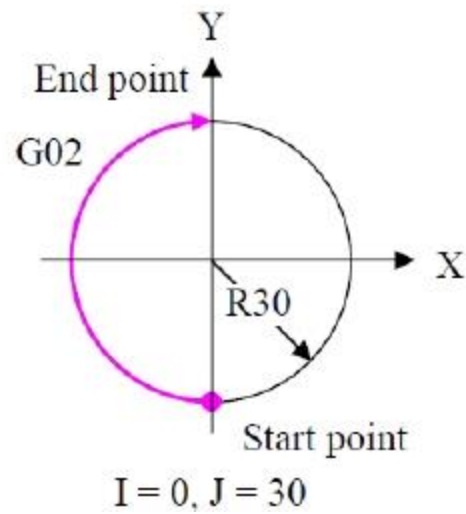
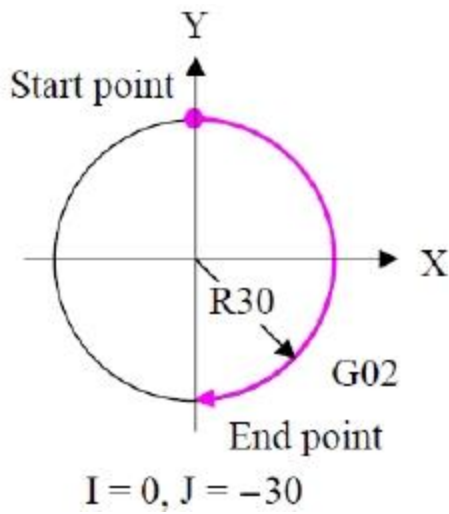

3. R is the commanded value of the arc radius. The R value is positive when the arc is less than or equals to 180° , and negative when the arc is greater than 180° and less than 360° .

For full circle (360°) cutting, the I, J and K commands are necessary. We suggest to choose the position at 0° , or 90° , or 180° , or 270° as the start point for simplifying calculation and easier error detection.

Because the start point and the end point are the same, the X and Y commands in the format can be omitted.

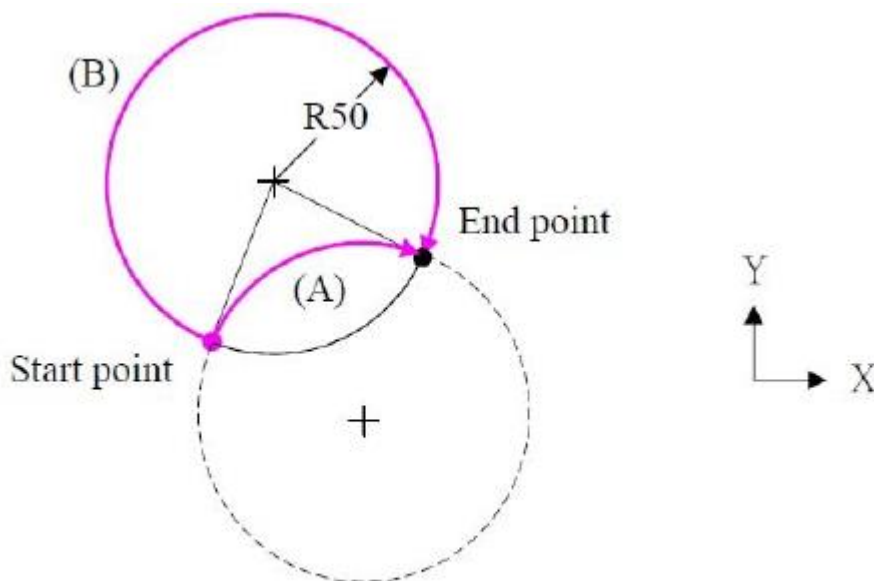

Arc is less than $180^\circ \rightarrow$ Path (A) `G91 G02 X60. Y20. R+50. F100 ;`

Arc is greater than $180^\circ \rightarrow$ Path (B) `G91 G02 X60. Y20. R-50. F100 ;`

4. For full circle cutting, the command is G02 I__, or G02 J__, or G02 K__. If command is given as G02 R__, there will be no action at all and no alarm occurs.
5. If commands I, J, K and R are given in the same block, there will be no action at all and no alarm occurs.

Note : For selecting the plane of cutting path, please refer to the section of G17/G18/G19 Cutting plane selection.

Example :

Conditions : Tool diameter ϕ 20 mm
 spindle speed 800 rpm,
 Feedrate 160 mm/min
 Arc radius 50 mm
 cutting depth 5 mm along Z axis

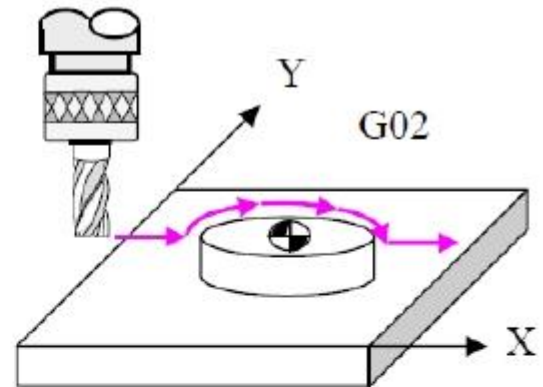

1. 0~180°

```
O1000 ;
G80 G40 G49 G00 G17 ;
G90 G54 X-70. Y0 ;
G43 Z3. H01 M3 S800 ;
G01 Z-5. F80 ;
X-50. Y0 F160 ;
G02 X50. Y0 R50. ;
G01 X70. Y0 ;
Z3. ;
G49 G00 Z0 M5 ;
M30 ;
```

Or

```
O1000 ;
G80 G40 G49 G00 G17 ;
G90 G54 X-70. Y0 ;
G43 Z3. H01 M3 S800 ;
G01 Z-5. F80 ;
X-50. Y0 F160 ;
G02 X50. Y0 I50. J0 ;
G01 X70. Y0 ;
Z3. ;
G49 G00 Z0 M5 ;
M30 ;
```

Note : (1) The above example doesn't consider the tool radius offset. For tool radius offset, please refer to the section of G40/G41/G42 Cutter compensation.
 (2) In the program, the commanded dimension is ϕ 100mm. Because it doesn't consider the tool radius offset, the actual dimension after cutting becomes ϕ 80mm.

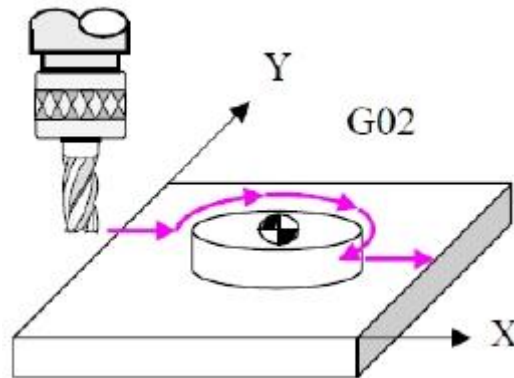

2. 181°~359°

O1000 ;
 G80 G40 G49 G00 G17 ;
 G90 G54 X-70. Y0 ;
 G43 Z3. H01 M3 S800 ;
 G01 Z-5. F80 ;
 X-50. Y0 F160 ;
 G02 X35.35 Y-35.35 R-50. ;
 G01 X70. Y-35.35 ;
 Z3. ;
 G49 G00 Z0 M5 ;
 M30 ;

Or

O1000 ;
 G80 G40 G49 G00 G17 ;
 G90 G54 X-70. Y0 ;
 G43 Z3. H01 M3 S800 ;
 G01 Z-5. F80 ;
 X-50. Y0 F160 ;
 G02 X35.35 Y-35.35 I35.35 J0 ;
 G01 X70. Y-35.35 ;
 Z3. ;
 G49 G00 Z0 M5 ;
 M30 ;

3. 360°

O1000 ;
 G80 G40 G49 G00 G17 ;
 G90 G54 X-70. Y0 ;
 G43 Z3. H01 M3 S800 ;
 G01 Z-5. F80 ;
 X-50. Y0 F160 ;
 G03 I50. J0 ;
 G01 X-70. Y0 ;
 Z3. ;
 G49 G00 Z0 M5 ;
 M30 ;

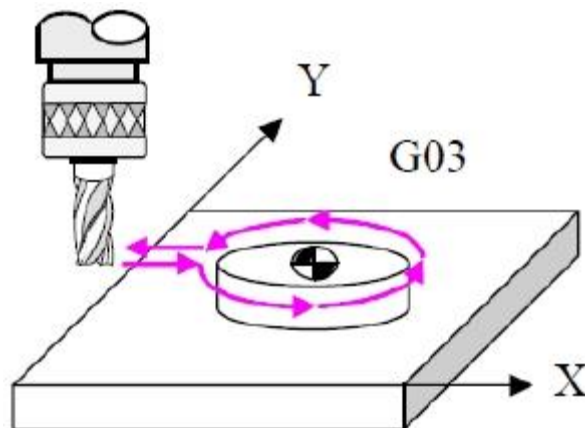

Helical Interpolation (G02 / G03)

Use of the command :

The helical interpolation is an arc movement along two axes combined with linear movement along the third axis with constant speed at the same time. Then, it becomes a path like a thread.

It is used for normal thread cutting and the cutting direction can be specified.

Format :

$(X_P - Y_P)$ G17 G02/G03 X__ Y__ Z__ R__ F__ ; or
G17 G02/G03 X__ Y__ Z__ I__ J__ F__ ;

$(Z_P - X_P)$ G18 G02/G03 X__ Y__ Z__ R__ F__ ; or
G18 G02/G03 X__ Y__ Z__ I__ K__ F__ ;

$(Y_P - Z_P)$ G19 G02/G03 X__ Y__ Z__ R__ F__ ; or
G19 G02/G03 X__ Y__ Z__ J__ K__ F__ ;

Meaning of command :

X, Y, Z : Coordinates of the end position

I : The vector from the start point of cutting to the arc center along X axis.

J : The vector from the start point of cutting to the arc center along Y axis.

K : The vector from the start point of cutting to the arc center along Z axis.

R : Arc radius

F : Feedrate

Description on I, J, K, R and judgement of the positive or negative value :

1. From the start point to the arc center, the vector values are I along the X axis, J along the Y axis and K along the Z axis.
2. The values of I, J and K are positive when the arc center is located at the positive side along the corresponding axes of the start point and negative when the arc center at the negative side of the start point.

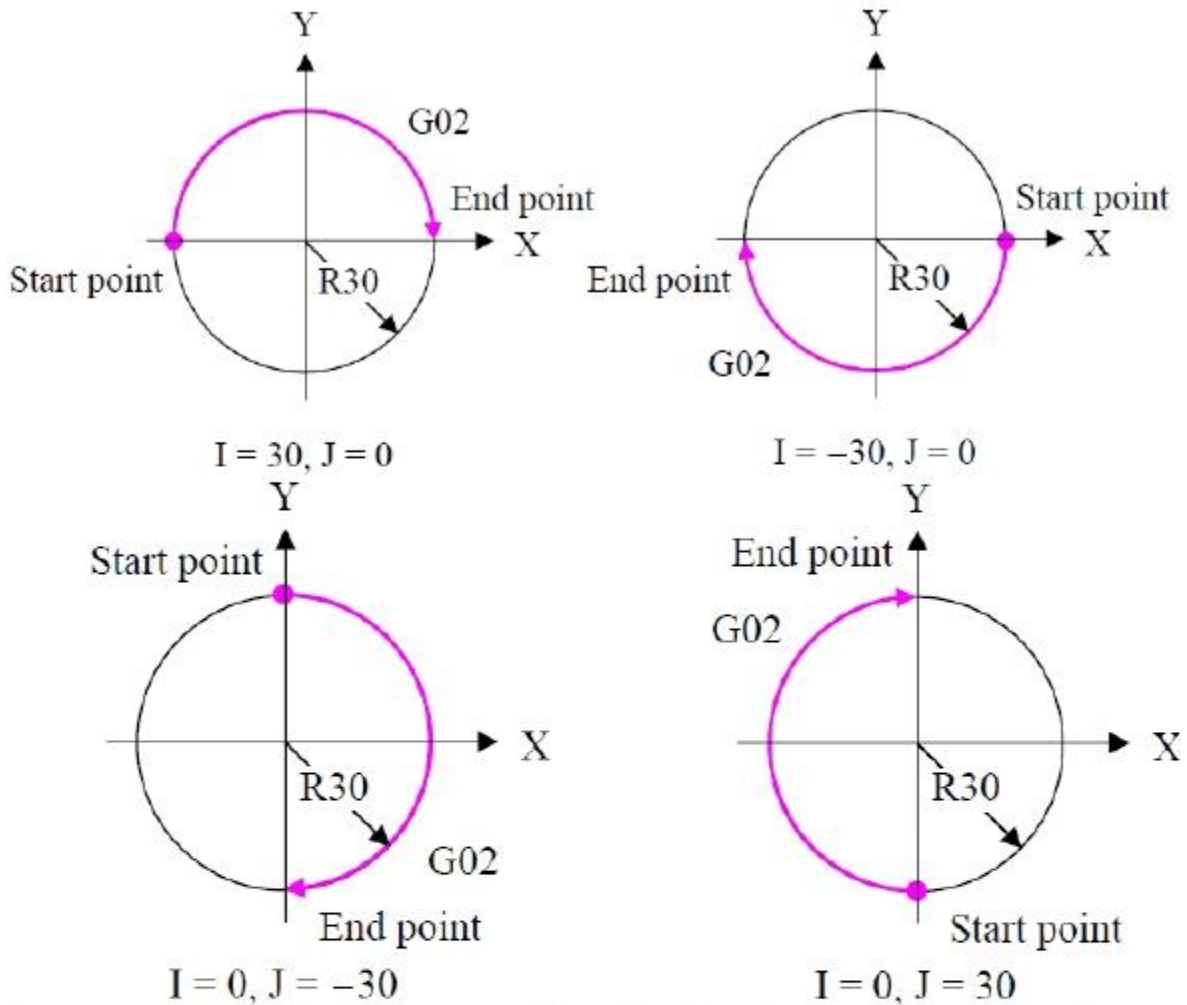

3. R is the commanded value of the arc radius. The R value is positive when the arc is less than or equals to 180° , and negative when the arc is greater than 180° and less than 360° .

For full circle (360°) cutting, the I, J and K commands are necessary. We suggest to choose the position at 0° , or 90° , or 180° , or 270° as the start point for simplifying calculation and easier error detection.

Because the start point and the end point are the same, the X and Y commands in the format can be omitted.

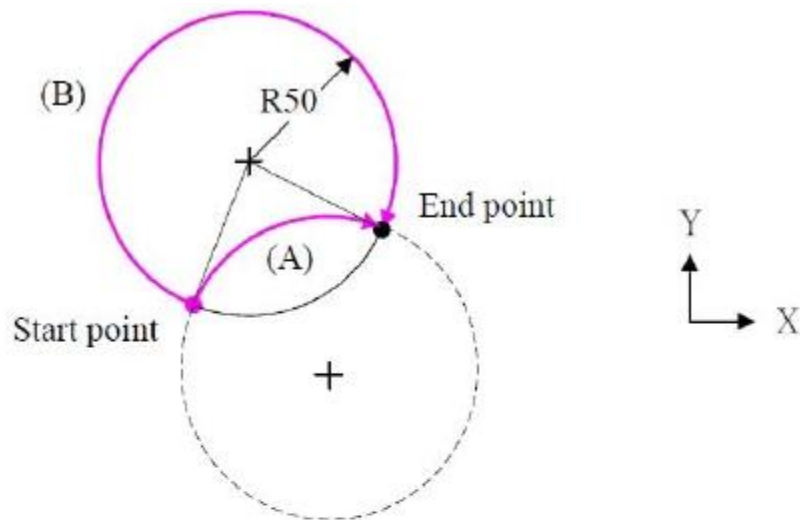

Arc is less than 180° → Path (A) `G91 G02 X60. Y20. R+50. F100 ;`

Arc is greater than 180° → Path (B) `G91 G02 X60. Y20. R-50. F100 ;`

4. For full circle cutting, the command is `G02 I__`, or `G02 J__`, or `G02 K__`. If command is given as `G02 R__`, there will be no action at all and no alarm occurs.
5. If commands I, J, K and R are given in the same block, there will be no action at all and no alarm occurs.

Note : For selecting the plane of cutting path, please refer to the section of `G17/G18/G19` Cutting plane selection.

Example :

Conditions : Tool diameter ϕ 20 mm
 spindle speed 800 rpm
 Feedrate 160 mm/min
 Arc radius 50 mm
 cutting depth 20 mm along Z axis

1. 0~180°

```
O1000 ;
G80 G40 G49 G00 G17 ;
G90 G54 X0 Y70. ;
G43 Z3. H01 M3 S800 ;
G01 Z0 F80 ;
G01 X0 Y50. F160 ;
G02 X0 Y-50. Z-20. R50. ;
G01 X0 Y-70. ;
Z3. ;
G49 G00 Z0 M5 ;
M30 ;
```

or

```
O1000 ;
G80 G40 G49 G00 G17 ;
G90 G54 X0 Y70. ;
G43 Z3. H01 M3 S800 ;
G01 Z0 F80 ;
G01 X0 Y50. F160 ;
G02 X0 Y-50. Z-20. I0 J-50. ;
G01 X0 Y-70. ;
Z3. ;
G49 G00 Z0 M5 ;
M30 ;
```

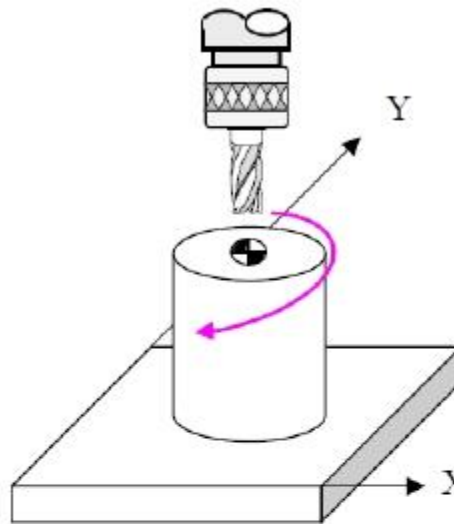

2. 181°~359°

O1000 ;

G80 G40 G49 G00 G17 ;

G90 G54 X-35.35 Y70. ;

G43 Z3. H01 M3 S800 ;

G01 Z0 F80 ;

G01 X-35.35 Y35.35 F160 ;

G03 X50. Y0 Z-20. R-50. ;

G01 X70. Y0 ;

Z3. ;

G49 G00 Z0 M5 ;

M30 ;

or

O1000 ;

G80 G40 G49 G00 G17 ;

G90 G54 X-35.35 Y70. ;

G43 Z3. H01 M3 S800 ;

G01 Z0 F80 ;

G01 X-35.35 Y35.35 F160 ;

G03 X50. Y0 Z-20. I35.35 J-35.35 ;

G01 X70. Y0 ;

Z3. ;

G49 G00 Z0 M5 ;

M30 ;

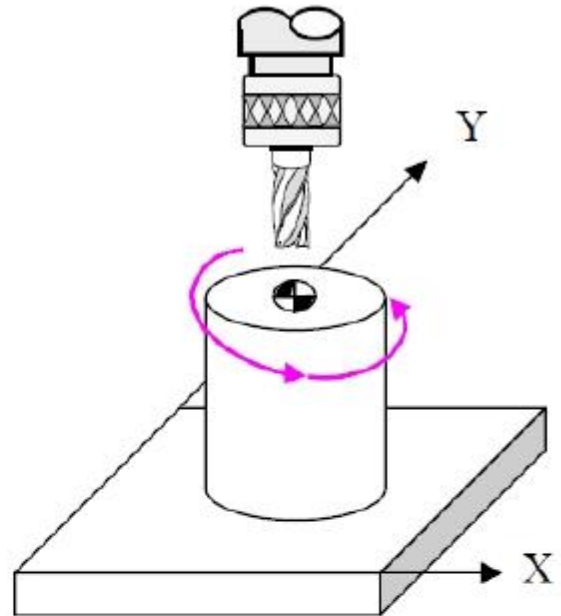

3. 360°

```
O1000 ;  
G80 G40 G49 G00 G17 ;  
G90 G54 X0 Y70. ;  
G43 Z3. H01 M3 S800 ;  
G01 Z0 F80 ;  
G01 X0 Y50. F160 ;  
M98 P42000 ;  
G90 G00 G40 X0 Y70. ;  
Z3. ;  
G49 G00 Z0 M5 ;  
M30 ;
```

```
O2000 ;  
G91 G03 I0 J-50. Z-10. ;  
M99 ;
```

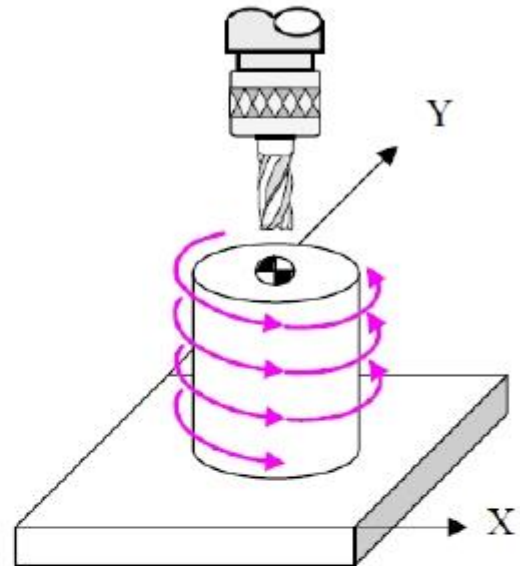

Note : The maximum arc angle for the helical interpolation in a block is 360°. Therefore, if continuous full circle helical cutting is needed, the editing manner of M98 Main program calling subprogram can be used for simplifying the program.
(Please refer to the section of M98 / M99 subprogram calling.)

Dwell

Use of the command :

It is used for a specified time interval of pause in the program.

Format :

G04 X__ ; or

G04 P__ ;

Meaning of command :

X : Pause time(unit : sec.), decimal point permitted.

P : Pause time(unit : 0.001sec.), decimal point not permitted.

Example :

Pause for 2 seconds at the hole bottom.

O1000 ;

G80 G40 G49 G00 G17 ;

G90 G54 X0 Y0 ;

G43 Z3. H01 M3 S800 ;

G01 Z-5. F80 ;

G04 X2. ;

G00 Z3. ;

G49 G00 Z0 M5 ;

M30 ;

Or

O1000 ;

G80 G40 G49 G00 G17 ;

G90 G54 X0 Y0 ;

G43 Z3. H01 M3 S800 ;

G01 Z-5. F80 ;

G04 P2000 ;

G00 Z3. ;

G49 G00 Z0 M5 ;

M30 ;

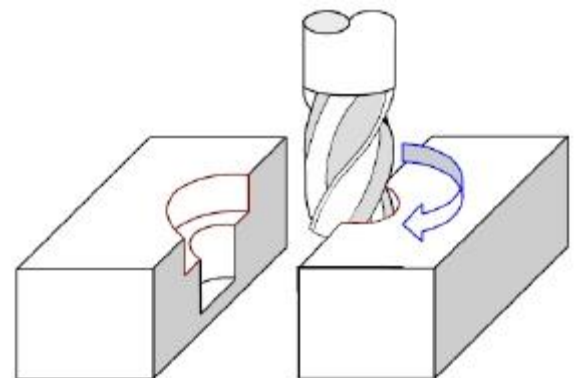

Pause for 2 seconds
at the hole bottom.

- Note : (1) The G04 is a one – shot G code. It is effective only for the specified block with this code.
- (2) If X or P command is omitted, the G04 is the same function as the the code G09 Exact Stop.
- (3) If the P command value is with decimal point, the alarm No. 007 will occur.

Exact Stop (G09)

Use of the command :

When higher precision is required at the point to change moving direction, it is used for confirming in-position for the specified block and then continue the next block.

Format :

G09 G__ X__ Y__ ;

Meaning of command :

Add the command G09 in the block which needs the function of exact stop.

Example :

```
O1000 ;  
G80 G40 G49 G00 G17 ;  
G90 G54 X0 Y0 ;  
G43 Z3. H01 M3 S800 ;  
G01 Z-5. F80 ;  
G01 X10. Y10. F160 ;  
G09 X100. Y10. ;  
G09 X100. Y90. ;  
G09 X10. Y90. ;  
G09 X10. Y10. ;  
G00 X0 Y0 ;  
Z3. ;  
G49 G00 Z0 M5 ;  
M30 ;
```

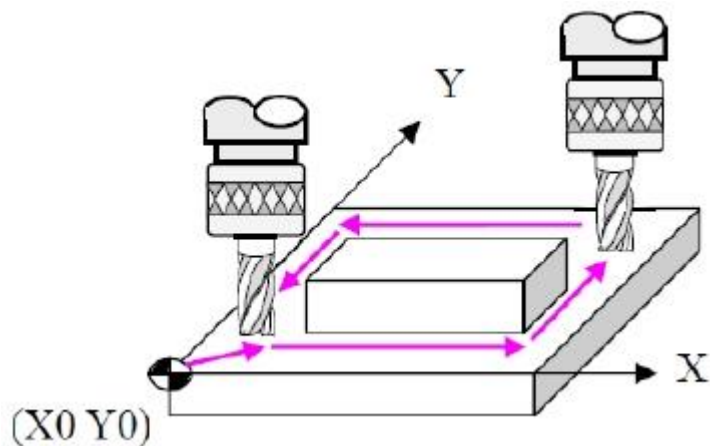

Note : (1) The G09 is a one – shot G code. It is effective only for the specified block with this code.
(2) If every movement needs this function, the G09 must be written in all blocks of movement.

Programmable Data Input (G10)

Tool length offset / radius offset

Use of the command :

It is used for changing a tool length offset or a radius offset automatically during program execution.

Format :

G10 L__ P__ R__ ;

Meaning of command :

- L : Type No. of compensation.
- P : Offset number.
- R : Offset value.

1. Tool offset memory A

G10 L11 P__ R__ ; (Geometry offset value H/D)

OFFSET		O0002 N00000	
NO.	DATA	NO.	DATA
001	-315.264	009	0.000
002	-301.668	010	10.000
003	-250.982	011	0.000
004	10.000	012	0.000
005	5.000	013	0.000
006	0.000	014	0.000
007	0.000	015	0.000
008	0.000	016	0.000
ACTUAL POSITION (RELATIVE)			
X	-245.792	Y	-193.952
Z	-119.863		
} ^		S 0 T0000	
MDI **** ** *		11:42:10	
OFFSET	SETTING	WORK	(OPRT) +

2. Tool offset memory B

G10 L10 P __ R __ ; (Geometry offset value H/D)

G10 L11 P __ R __ ; (Wear offset value H/D)

OFFSET		O0002 N00000	
NO.	GEOMETRY	WEAR	
001	-315.534	0.050	
002	-301.295	0.020	
003	-292.202	0.100	
004	10.000	0.000	
005	0.000	0.000	
006	0.000	0.000	
007	0.000	0.000	
008	0.000	0.000	
ACTUAL POSITION (RELATIVE)			
X	-245.792	Y	-193.952
Z	-119.865		

S 0 T0000

MDI **** * * * * 11:53:48

OFFSET SETING WORK (OPRT) +

3. Tool offset memory C

G10 L10 P __ R __ ; (Geometry offset value /H)

G10 L12 P __ R __ ; (Wear offset value /D)

G10 L11 P __ R __ ; (Geometry offset value /H)

G10 L13 P __ R __ ; (Wear offset value /D)

OFFSET		O0002 N00000		
NO.	GEOM (H)	WEAR (H)	GEOM (D)	WEAR (D)
001	-312.528	0.500	10.000	0.020
002	-320.113	0.000	5.000	0.000
003	-239.520	0.000	0.000	0.000
004	0.000	0.000	0.000	0.000
005	0.000	0.000	0.000	0.000
006	0.000	0.000	0.000	0.000
007	0.000	0.000	0.000	0.000
008	0.000	0.000	0.000	0.000
ACTUAL POSITION (RELATIVE)				
X	-245.792	Y	-193.952	
Z	-119.865			

S 0 T0000

MDI **** * * * * 11:27:55

OFFSET SETING WORK (OPRT) +

Example :

Change the tool length offset setting of No.6 as -200.

(Memory mode A of tool length compensation)

O1000 ;

G90 G10 L11 P6 R-200. ;

M30 ;

Workpiece Coordinate System Data

Use of the command :

It is used for changing settings of a work coordinate system automatically during program execution.

Format :

G10 L __ P __ X __ Y __ Z __ ;

Meaning of command :

L : Group No. of work coordinate system.

P : Work coordinate system number.

X, Y, Z : Setting value of work coordinate system.

1. Standard work coordinate system (G54~G59)

G10 L2 P __ X __ Y __ Z __ ;



2. Extended work coordinate system (G54.1 P1 ~ P48 / G54.1 P1 ~ P300)

G10 L20 P__ X__ Y__ Z__ ;

WORK COORDINATES				O0011 N00000			
(G54)							
NO.		DATA		NO.		DATA	
P01	X	-506.256		P03	X	0.000	
(G54.1)	Y	-358.235	(G54.1)	Y		0.000	
	Z	0.000		Z		0.000	
P02	X	-300.321		P04	X	0.000	
(G54.1)	Y	-351.102	(G54.1)	Y		0.000	
	Z	-10.000		Z		0.000	
) ^							
S 0 T0000							
MDI **** * * * * *				08:31:42			
OFFSET	SETTING	WORK		(OPRT)	+		

Example :

Change the offset settings in the 5th work coordinate system (G58) as
(X-300. Y-400. Z0)

O1000 ;

G90 G10 L2 P5 X-300. Y-400. Z0 ;

M30 ;

Note : If the status is incremental G91 (referring to the section of G90 / G91 Absolute / Incremental commands) before the command G10, the offset setting will be executed as the incremental mode.

Programmable Parameter Input (G10/G11)

Use of the command :

It is used for changing a parameter setting or pitch error offset automatically during program execution.

Format :

```
G10 L50 ;  
N__ P__ R__ ;  
G11 ;
```

Meaning of command :

G10 : Automatic programmable parameter input ON.

L50 : Executing the function of automatic programmable parameter input.

N : Parameter No.

P : Axis No.

R : Setting value of the parameter.

G11 : Automatic programmable parameter input OFF.

Example :

(This is just an example for explanation. Do not do the same setting into the machine parameter.)

1. Assume parameters will be changed as the No.1406 to 0000 0001, No.1410 to 8000 and No.1420 Z axis to 24000, the program will be as follows :

```
O1000 ;  
G10 L50 ;  
N1406 R00000001 ;  
N1410 R8000 ;  
N1420 P3 R24000 ;  
G11 ;  
M30 ;
```

2. Assume the pitch error offset will be changed as the No.0 to -1 and No.10 to 2, the program will be as follows :

PIT-ERROR SETTING						O0002	N00000
NO.	DATA	NO.	DATA	NO.	DATA		
0000	0	0010	1	0020	1		
(X) 0001	-1	0011	1	0021	-1		
0002	1	0012	-1	0022	2		
0003	-1	0013	-1	0023	-1		
0004	1	0014	2	0024	1		
0005	1	0015	1	0025	1		
0006	-1	0016	2	0026	1		
0007	-1	0017	1	0027	1		
0008	1	0018	1	0028	1		
0009	-1	0019	1	0029	-1		

} _

S 0 T0000

MDI **** * * * * 12:11:06

PITCH SV-PRM (OPRT) +

O2000 ;

G10 L50 ;

N10000 R-1 ; → No.0

N10010 R2 ; → No.10

G11 ;

M30 ;

(N : Block No. of pitch error offset = 10000 + offset No.)

Note : (1) Generally, the R address cannot be written with decimal point.
 (2) Other NC commands cannot be used under this mode.
 (3) Before executing this function, the command G80 has to be used for canceling canned cycles.

Polar Coordinate Command (G15/G16)

Use of the command :

The end point of movement in the program can be expressed with the polar coordinate system and commanded in radius and angle (usually used for canned cycle).

Format :

```
G16 X__ Y__ ;
G15 ;
```

Meaning of command :

G16 : Polar coordinate command ON.

X : Radius

Y : Angle

G15 : Polar coordinate command OFF.

Example :

```
O1000 ;
G80 G40 G49 G00 G17 ;
G90 G54 G00 X0 Y0 ;
G43 Z3. H01 M3 S800 ;
G98 G81 Z-10. R3. F160 K0 ;
G16 ;
X50. Y0 ;
Y45. ;
Y90. ;
Y135. ;
Y180. ;
Y225. ;
Y270. ;
Y315. ;
G15 ;
Z30. ;
G80 ;
G49 G00 Z0 M5 ;
M30 ;
```

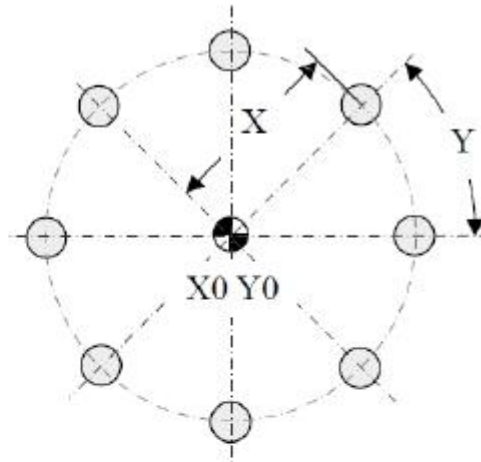

If the program is written in incremental command,
the program can be simplified as **G91 Y45. K7. ;**

Plane Selection (G17/G18/G19)

Use of the command :

It is used to define the work plane for arc cutting movement.

Format :

G17 ;
G18 ;
G19 ;

Meaning of command :

G17 : X-Y plane
G18 : Z-X plane
G19 : Y-Z plane

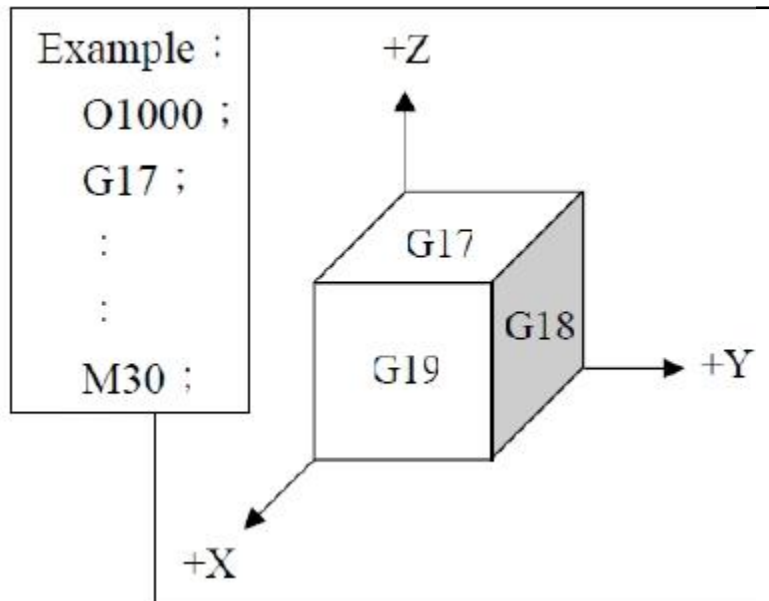

Parameter

No.	Meaning
5101 # 0	The drilling axis in the drilling canned cycle is 0 : Always the Z-axis 1 : The axis selected by the program
3402 # 2, # 1	Plane selected when power is turned on 0, 0 : G17 mode (X _P - Y _P) 0, 1 : G18 mode (Z _P - X _P) 1, 0 : G19 mode (Y _P - Z _P)

Note : (1) G17 plane can be set as the status when machine start by parameter setting.
 (2) If the work plane changes during cutting, the command of plane selection has to be changed too.
 (3) If the work axis is not in the selected work plane during arc cutting (G02 / G03), the alarm No.021 will occur.

Inch and Metric Conversion (G20/G21)

Use of the command :

It is used for switching inch input or metric input.

Format :

G20 ;

G21 ;

Meaning of command :

G20 : Inch input.

G21 : Metric input.

Increment system	Least input increment
ISB	0.001 mm
	0.0001 inch
ISC	0.0001 mm
	0.00001 inch

Example :

Enter X1.23456

Increment system	Display
ISB	1. 234 mm
	1.2345 inch
ISC	1.2345 mm
	1.23456 inch

Either inch or metric input can be selected on screen.

1. Under the MDI mode, press the function key 

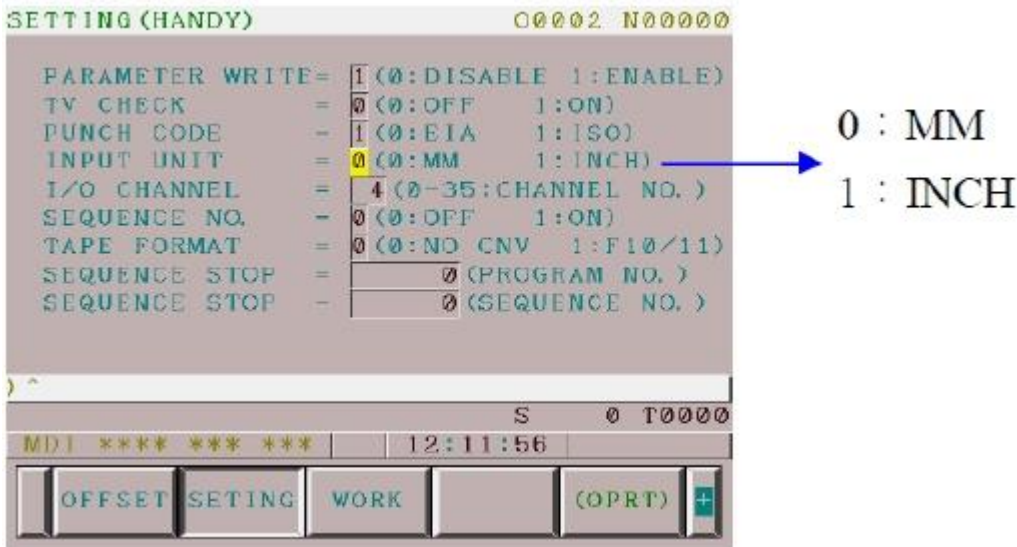

2. Press the soft key [SETING].



3. Move the cursor to the “ INPUT UNIT ” by pressing cursor keys.

4. Path 1. (1) Press the soft key [(OPRT)].

(2) Press the soft key [ON : 1] or [OFF : 0].

Path2. (1) Press numeric keys  or .

(2) Press the input key  or press the soft key [INPUT]

Parameter

No.	Meaning
1001 # 0	Least command increment on the linear axis 0 : In mm 1 : In inches
5006 # 0	When the unit is switched between the inch and metric systems, automatic tool offset value conversion is 0 : Not performed 1 : Performed

Note : Combined use of the inch system and the metric system is not allowed.

Return to Reference Position (G28)

Use of the command :

It is used for executing machine origin return in program.

Format :

G28 X__ Y__ Z__ ;

Meaning of command :

The command G28 includes to return the first reference point too. Therefore, it is not necessary to specify the coordinates of the origin. When X, Y, Z axes are commanded to return the machine origin, machine crash such as tool colliding the workpiece can be avoided by passing the first reference point. The command G91 is used together usually.

Example :

```
O1000 ;  
G80 G40 G49 G00 G17 ;  
G91 G28 X-300. Y50. Z250. ;  
:  
:  
M30 ;
```

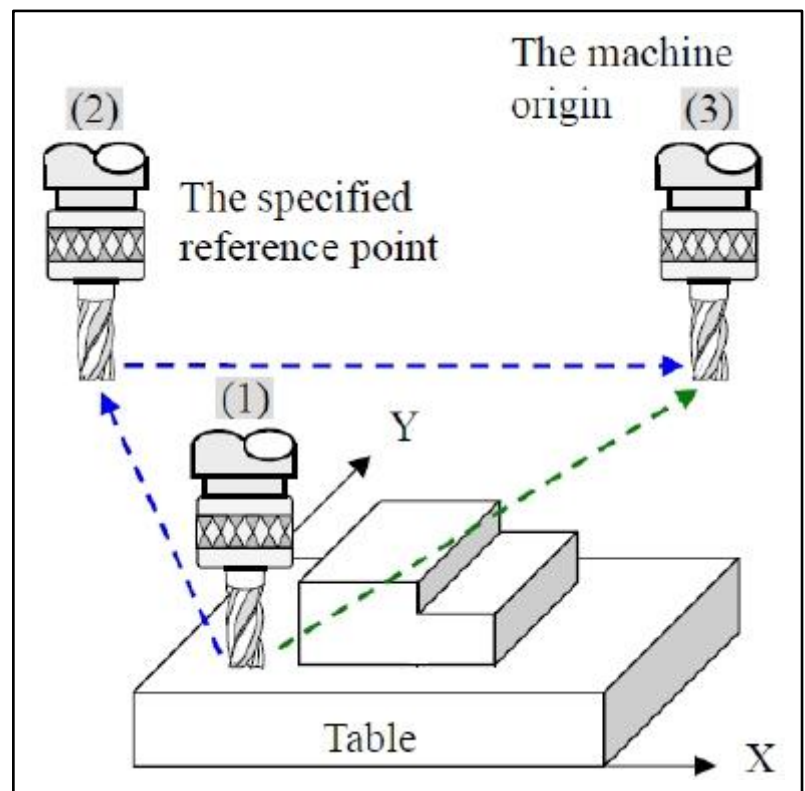

It is possible to get crash if the tool moves from (1) → (3) directly. So, change the moving path as (1) → (2) → (3) is the proper one.

Note : (1) For the X,Y,Z values with the command G28, they are just the coordinates of the absolute program origin when G90 is used, and are the position relative to the current tool position when G91 is used.

(2) Usually, G28 is used as follows(The tool returns the machine origin directly.)

O1000 ;

G80 G40 G49 G00 ;

G91 G28 Z0 ; → Z axis returns the machine origin.

G28 X0 Y0 ; → X,Y axes return the machine origin.

Return from Reference Position (G29)

Use of the command :

It is used for moving the tool from the machine origin to the specified position by passing the specified reference point (G28 or G30) to avoid the possible machine crash.

Format :

G29 X__ Y__ Z__ ;

Meaning of command :

X, Y, Z : Coordinates of the destination that the tool arrives after the specified reference point.

Example :

Assume the current tool position is at (1).

O1000 ;

G80 G40 G49 G00 G17 ;

G91 G28 X650. Y350. ; (1) → (2) → (4)

G29 X900. Y150. ; (4) → (2) → (3)

:

:

M30 ;

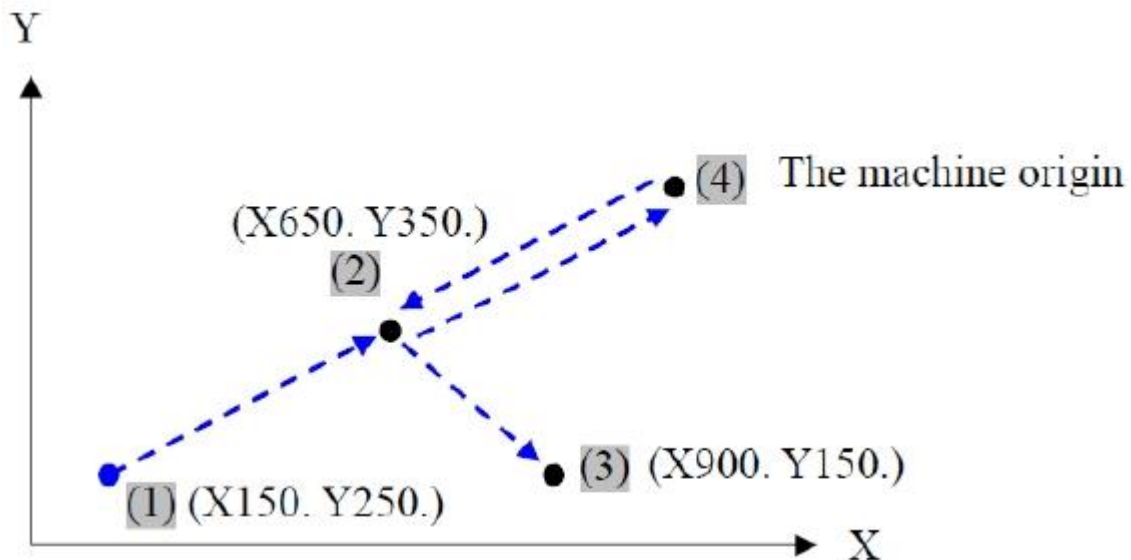

Note : (1) The above actions are all with rapid movement.

(2) Before the command G29 is used, the command G28 or G30 is needed usually for specifying the reference point in G29 movement.

2nd, 3rd and 4th Reference Position Return (G30)

Use of the command :

It is used to move the tool to return 2nd or 3rd or 4th reference point during program execution by passing a specified reference point

Format :

G30 X__ Y__ Z__ ;

Meaning of command :

P : Sequence no. of the reference point.

P2 ~ The 2nd reference point, P3 ~ The 3rd reference point,

P4 ~ The 4th reference point

X, Y, Z : Coordinates of the specified reference point.

Example :

Assume : The current tool position is at (1). The 2nd reference point is set in the parameter No.1241 X = -600000, Y = -45000

O1000 :

G80 G40 G49 G00 G17 ;

:

G90 G30 P2 X-200. Y-100. ; (1) → (2) → (3)

:

M30 ;

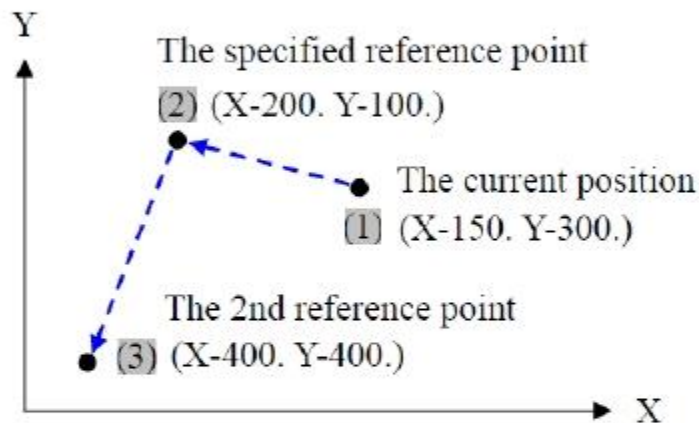

Parameter

No.	Meaning
1241	Coordinate value of the second reference position
1242	Coordinate value of the third reference position
1243	Coordinate value of the fourth reference position

Note : (1) The 2nd, 3rd and 4th reference points are set in the parameters with machine coordinates.

(2) The G29 can be used together.

Cutter Dimensional Compensation (G40/G41/G42)

Use of the command :

For cutting side face, the cutting path of the program should be along the outer edge and not along the center of the cutter. Because there is difference of cutter radius, a tool radius offset is applied in the program for compensating such difference and achieving the required actual cutting path.

Format :

G41/G42 X__ Y__ D__ F__ ;

G40 X__ Y__ ;

Meaning of command :

G41 : Tool radius offset for shifting tool to the left.

G42 : Tool radius offset for shifting tool to the right.

G40 : Tool radius offset cancelled.

X, Y : Position of the tool arrival after offset applied or cancelled.

D : Offset no. for the tool radius.

F : Feedrate

Example :

O1000 ;

G80 G40 G49 G00 G17 ;

G90 G54 X-50. Y-50. ;

G43 Z3. H01 M3 S800 ;

G01 G42 X0 Y0 D11 F160 ;

X100. Y0 ;

X0 Y100. ;

X0 Y0 ;

G00 G40 X-50. Y-50 ;

Z3. ;

G49 G00 Z0 M5 ;

M30 ;

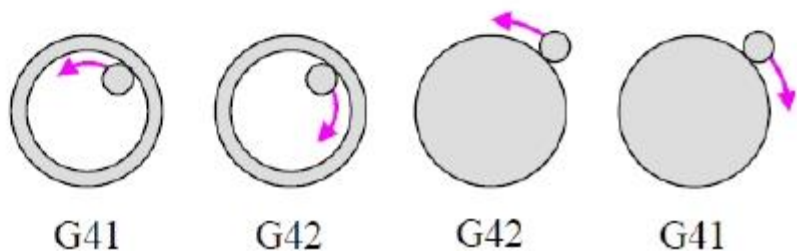
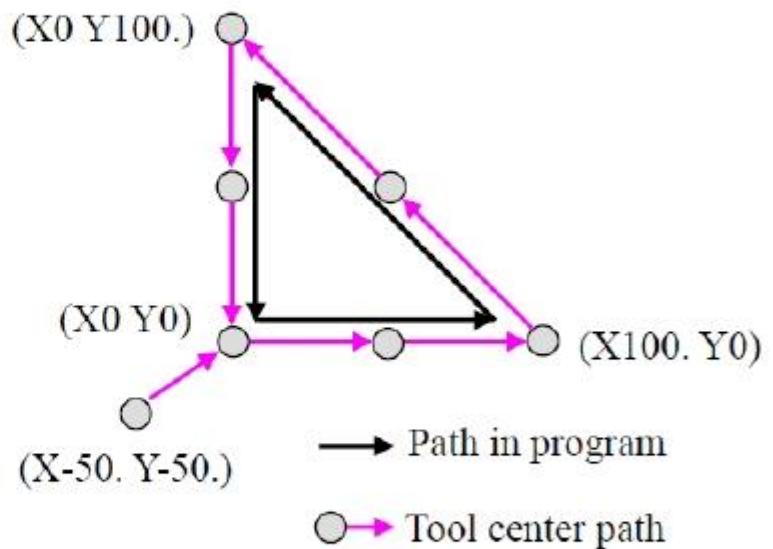

Note : (1) The offset No. for tool radii (D) and for tool lengths (H) are all displayed and set on the screen OFFSET.
(2) The selection of G41/G42 is based on the direction of tool movement during cutting

Tool Length Offset (G43/G44/G49)

Use of the command :

Because of different tool lengths during machining, heights from tool tip to the work datum plane become different for each tool. Therefore, the distance from tool tip to the work datum plane is measured in advance and input into the corresponding offset no. on the screen OFFSET. By using this function in the program, the tool can be moved to the specified position.

Format :

G43/G44 Z__ H__ ;
G49 ;

Meaning of command :

G43 : Tool length offset for shifting to +Z direction.

G44 : Tool length offset for shifting to -Z direction.

G49 : Tool length offset cancelled.

Z : Position of the tool arrival after offset applied or cancelled.

H : Offset no. for the tool length.

Example :

```
O1000 ;  
G80 G40 G49 G00 G17 ;  
G90 G54 X0 Y0 ;  
G43 Z3. H01 M3 S800 ; (On the screen OFFSET No.1 = -391.68)  
G81 Z-20. F160 ;  
G80 ;  
G49 G00 Z0 M5 ;  
M30 ;
```

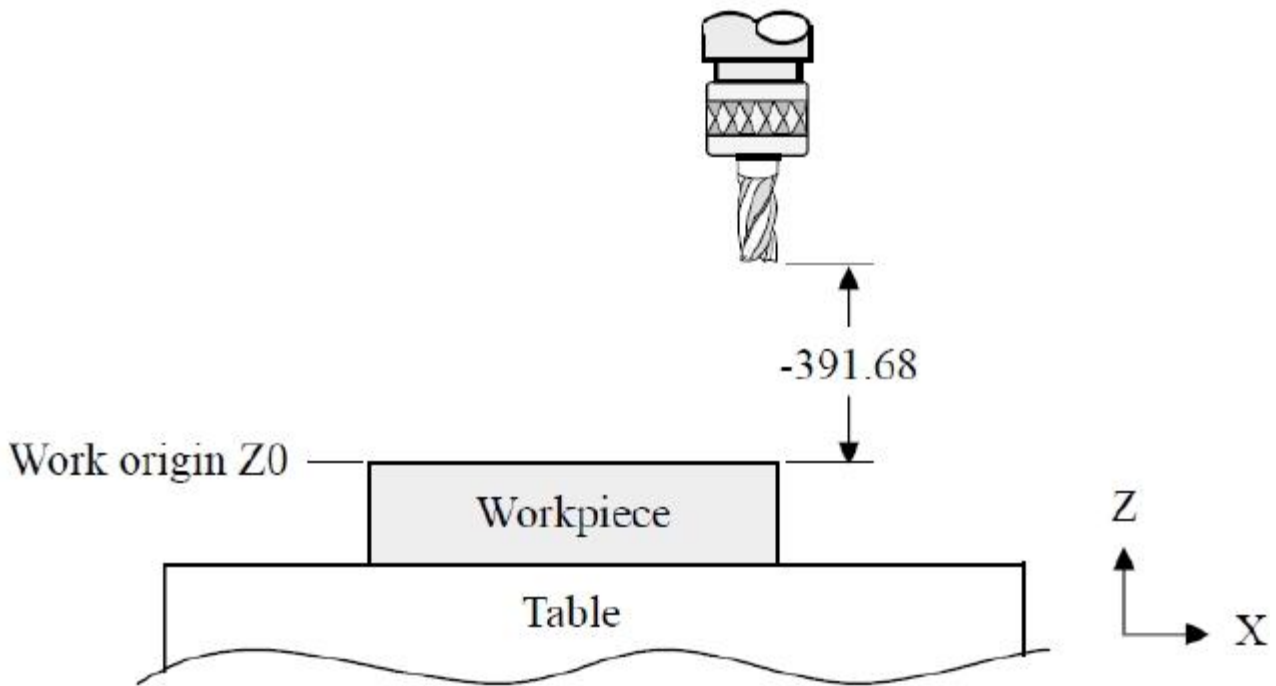

Scaling (G50/G51)

Use of the command :

To do magnification or contraction with some specified scale on the profile to be cut according to the path in program.

Format :

```
G51 X__ Y__ Z__ P__ ;  
G51 X__ Y__ Z__ I__ J__ K__ ;  
G50 ;
```

Meaning of command :

G51 : Scaling ON.

G50 : Scaling OFF.

X, Y, Z : Coordinates of the datum point for scaling.

P : scale for magnification or contraction (effective for all of X, Y, Z axes, unit as 0.001).

I, J, K : Scales specified for X, Y, Z axes individually.

Example :

Contraction on X, Y axes with scale 0.5

O1000 ;

G80 G40 G49 G00 G17 ;

G90 G54 X0 Y0 ;

G43 Z3. H01 M3 S800 ;

G81 Z-5. F160 ;

G90 G51 X52. Y42. I500 J500 K1000 ;

G01 X27. Y34. ;

X107. Y34. ;

X82. Y93. ;

X27. Y34. ;

G50 ;

Z3. ;

G49 G00 Z0 M5 ;

M30 ;

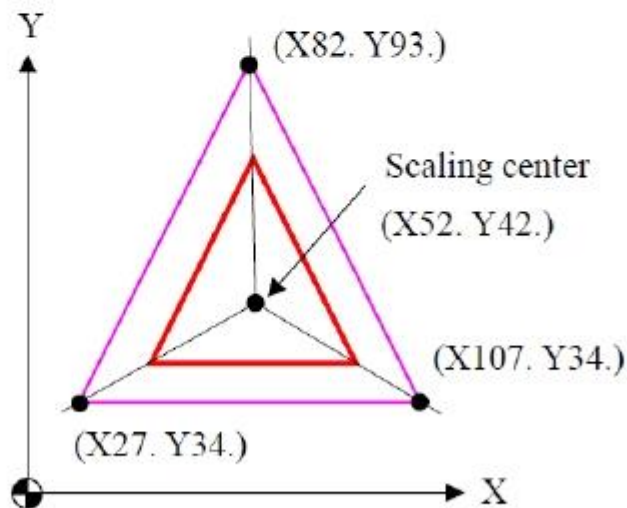

— Path in program

— Tool center path

Parameter

No.	Meaning
12 # 1	Mirror image for each axis (Command not needed.) 0 : Mirror image is OFF 1 : Mirror image is ON
5400 # 7	Scaling magnification unit 0 : 0.00001 times 1 : 0.001 times
5411	The preset scale used when no scale is commanded.

Note : (1) Commands I, J, K specify scales for each axis individually. If any scale is not specified with command, the scale setting in the parameter (not a zero value) is followed by the controller. Every axis must be specified with a scale. Even if the scale is 1:1, the scale should be not omitted.
(2) A cutting of ellipse can't be done by combining G51 with G02/G03.

Programmable Mirror Image (G50.1/G51.1)

Use of the command :

In case that a mirror image along some axis is required, this function can be used for reducing a new programming.

Format :

G50.1 X__ Y__ ;
G51.1 ;

Meaning of command :

G50.1 : Programmable mirror image ON.

G51.1 : Programmable mirror image OFF.

X, Y, Z : The axis for mirror image and coordinates of the datum point.

Example :

O1000 : (Main program)
G80 G40 G49 G00 G17 ;
G90 G54 G0 X0 Y0 ;
G43 Z10. H01 S800 M3 ;
M98 P1001 : (1)
G50.1 X0 ;
M98 P1001 : (1) → (2)
G50.1 Y0 ;
M98 P1001 : (2) → (3)
G50.1 X0 Y0 ;
M98 P1001 : (3) → (4)
G51.1 ;
G91 G28 Z0 M5 ;
M30 ;

O1001 : (Subprogram)

G90 G0 X50. Y50. ;
G01 Z-5. F100 ;
X100. F200 ;
Y100. ;
X50. Y50. ;
Z5. ;
G0 Z30. ;
X0 Y0 ;
M99 ;

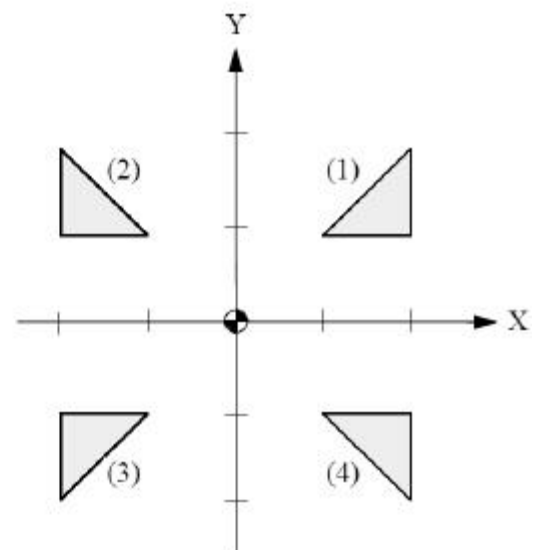

Local Coordinate System Setting (G52)

Use of the command :

By setting a local coordinate system instead of the original work coordinate system, complicate calculation can be simplified so that programming can be also easier. Besides, trouble due to lack amount of the work coordinate system (G54~G59) can get a solution.

Format :

```
G52 X__ Y__ Z__ ;  
G52 X0 Y0 Z0 ; → Cancel  
G50 ;
```

Meaning of command :

X, Y, Z : Offset values of the origin of the local coordinate system relative to the original work coordinate system (G54~G59).

Example :

```
O1000 ;  
G80 G40 G49 G00 G17 ;  
G91 G28 Z0 ;  
G28 X0 Y0 ;  
T1 ;  
M6 ;  
G90 G54 X0 Y0 ;
```

↗ Tool moves to the origin of the work coordinate system in the program for the work piece A.

```
⋮ } Program for the work piece A.  
⋮
```

```
G90 G52 X200. Y100. ;
```

↗ The origin of the G54 coordinate system is shifted to the position (X200. Y100.).

```
G90 G00 X0 Y0 ;
```

→ Tool moves to the origin of the work coordinate system in the program for the work piece B.

```
⋮ } Program for the work piece B.  
⋮
```

```
G90 G52 X0 Y0 ;
```

→ Cancel the origin offset in the program.

```
M30 ;
```

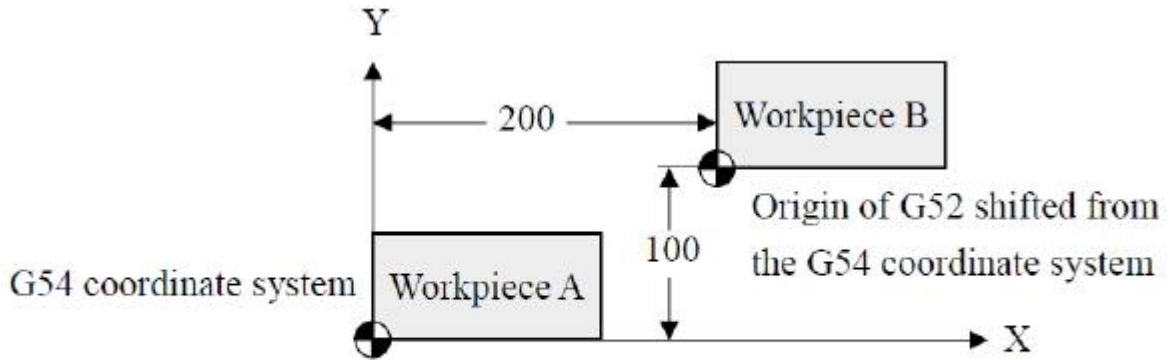

Note : G52 can be used only under the command of G54~G59.

Machine Coordinate System Selection (G53)

Use of the command :

When a specified position in the machine coordinate system will be moved to, the command G53 can be used directly and the inconvenience due to transference among G54, G92 and the machine coordinate can be avoided. This command must be combined with a command of movement such as G00.

Format :

G90 G00 G53 X__ Y__ Z__ ; or
 G90 G01 G53 X__ Y__ Z__ F__ ;

Meaning of command :

X, Y, Z : The specified position in machine coordinate.

Example :

```
O1000 ;
G80 G40 G49 G00 G17 ;
G00 G90 G54 X0 Y0 ;
G53 X-200. Y-200. Z-100. ;
:
M30 ;
```

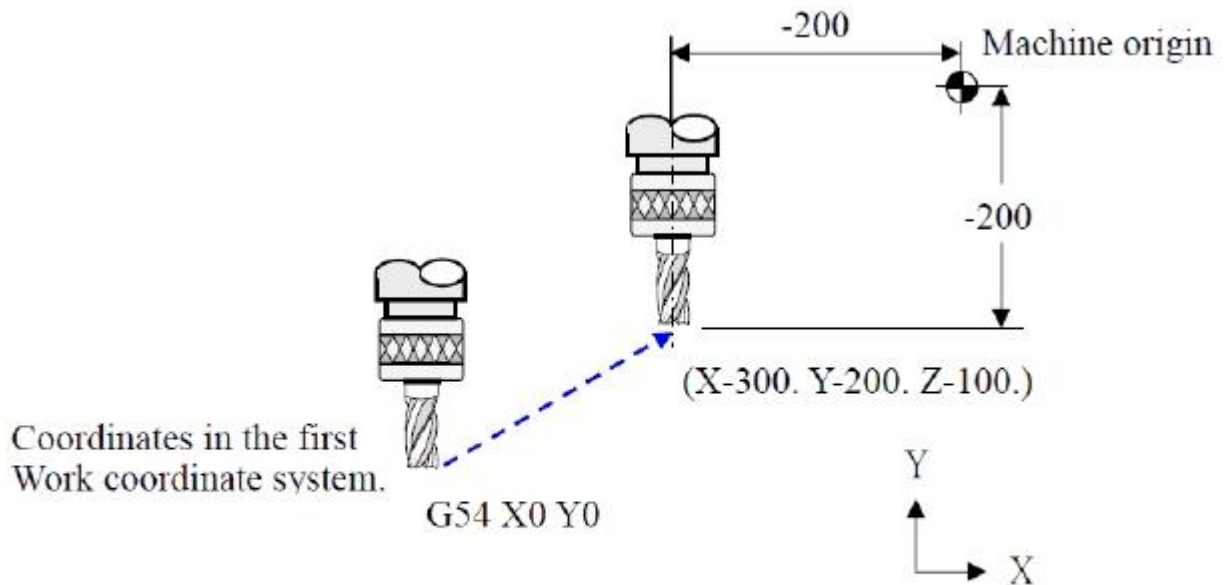
Note : (1) G53 is effective only under the absolute mode G90.
(2) G53 is a one-shot G code.

Workpiece Coordinate System Selection (G54~G59)

Use of the command :

It is used for setting a work origin (i.e. program origin). The setting values are the machine coordinates of the work origin. They are set in the OFFSET screen so as to get easier origin setting.

Format :

G90 G00 G54 X__ Y__ Z__ ;

Description on the format :

X, Y : The absolute coordinates in the work coordinate system, usually used together with commands G90 and G00.

Example :

O1000 ;

G80 G40 G49 G00 G17 ;

G90 G54 X0 Y0 ; → The offset values of the G54 work coordinate system are read at this moment.

M30 ;

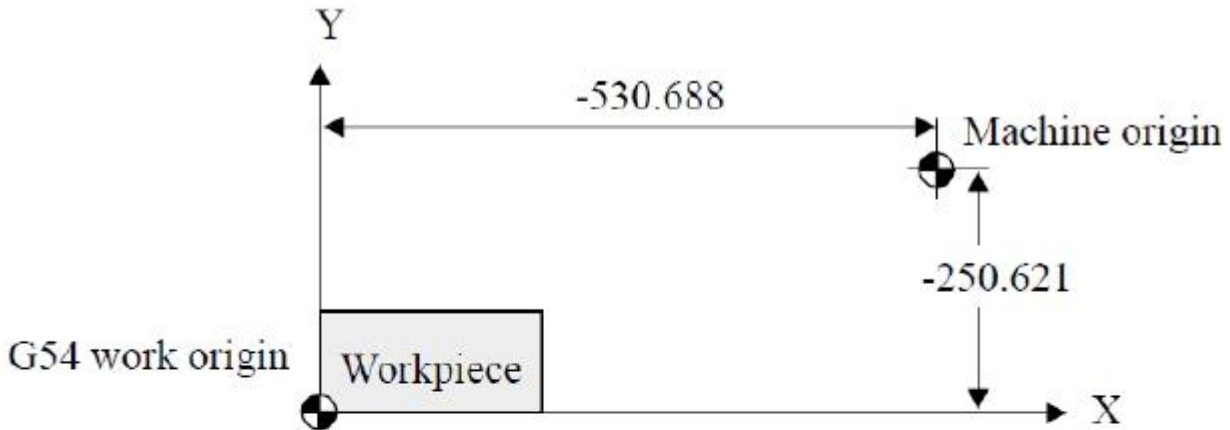

WORK COORDINATES				O0002 N00000			
(G54)							
NO.	DATA	NO.	DATA	NO.	DATA	NO.	DATA
00	X 0.000	02	X 0.000	(G55)	Y 0.000		
(EXT)	Y 0.000				Z 0.000		
	Z 0.000						
01	X -530.688	03	X 0.000				
(G54)	Y -250.621	(G56)	Y 0.000				
	Z 0.000		Z 0.000				
) ^							
S 0 T0000							
MDI **** * * * * 12:15:51							
[OFFSET] [SETING] [WORK] [(OPRT)] [+]							

Additional Workpiece Coordinate System (G54.1 P1~P48~P300)

Format :

G90 G00 G54 P1 X__ Y__ Z__ ;

WORK COORDINATES				O0002 N00000			
(G54)							
NO.	DATA	NO.	DATA	NO.	DATA	NO.	DATA
P01	X -506.266	P03	X 0.000	(G54.1)	Y 0.000		
(G54.1)	Y -358.235	(G54.1)	Y 0.000		Z 0.000		
	Z 0.000		Z 0.000				
P02	X -300.321	P04	X 0.000				
(G54.1)	Y -351.102	(G54.1)	Y 0.000				
	Z -10.000		Z 0.000				
) ^							
S 0 T0000							
MDI **** * * * * 12:17:18							
[OFFSET] [SETING] [WORK] [(OPRT)] [+]							

Parameter

No.	Meaning
1221	Workpiece coordinate system 1 (G54)
1222	Workpiece coordinate system 2 (G55)
1223	Workpiece coordinate system 3 (G56)
1224	Workpiece coordinate system 4 (G57)
1225	Workpiece coordinate system 5 (G58)
1226	Workpiece coordinate system 6 (G59)

Note : (1) Do not use the G92 absolute origin setting together for avoiding wrong action.

(2) Work coordinate system setting display : Press the function key  , then press the soft key [WORK], 01 = G54, 02 = G55, etc.

Single Direction Positioning (G60)

Use of the command :

For the purpose of exact positioning without backlash compensation, this command restricts movement along the only direction for positioning to avoid backlash. This is a one-shot G code and effective only in the block with it. The movement is similar to the G00.

Format :

G60 X__ Y__ Z__ ;

Meaning of command :

X, Y, Z : Coordinates of the point with exact positioning.

Example :

```
O1000 ;
G80 G40 G49 G00 G17 ;
G60 G54 X0 Y0 ;
G43 Z10. H01 M3 S1200 ;
G76 Z-20. Q0.5 F100 ;
G80 ;
G49 G00 Z0 M5 ;
M30 ;
```

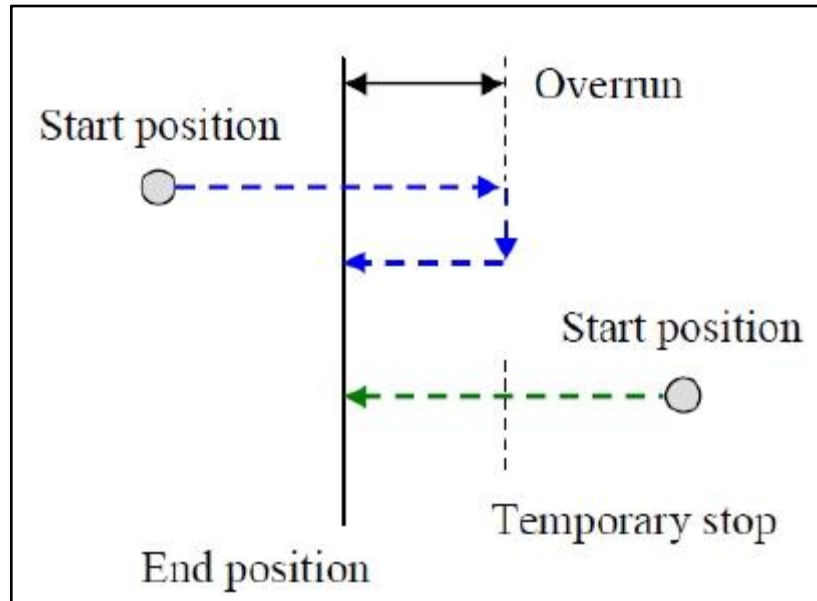

If the positioning direction is opposite to that for clearing backlash, the movement will pass the end point and return for positioning without backlash.

Parameter

No.	Meaning
5431 # 0	Single direction positioning is included in 0 : One-shot G codes (00 group) 1 : Modal G codes (01 group)
5440	Positioning direction and overrun distance in single direction positioning for each axis

Note : (1) During canned cycle for drilling, no single direction positioning is effective in Z axis.
 (2) The single direction positioning is not applied to the shift motion in the canned cycles of G76 and G87.
 (3) The direction set to the parameter is not effective in mirror image.

Exact Stop Mode (G61)

Use of the command:

It is used for confirming the positioning in the specified block completed (all machine movements have stopped). Then, the next action can be continued. Such a case is that a single block or a corner point for changing moving direction is required with high precision. This function after use is cancelled with G64.

Format :

G61 ;

Meaning of command :

G61 : Command is given before blocks for the exact stopping positions.

Example :

O1000 ;

;

G61 ;

G90 G54 G01 X0 Y0 F100 ;

X20. Y20. ;

X60. ;

Y60. ;

X20. ;

Y20. ;

G64 ;

;

M30 ;

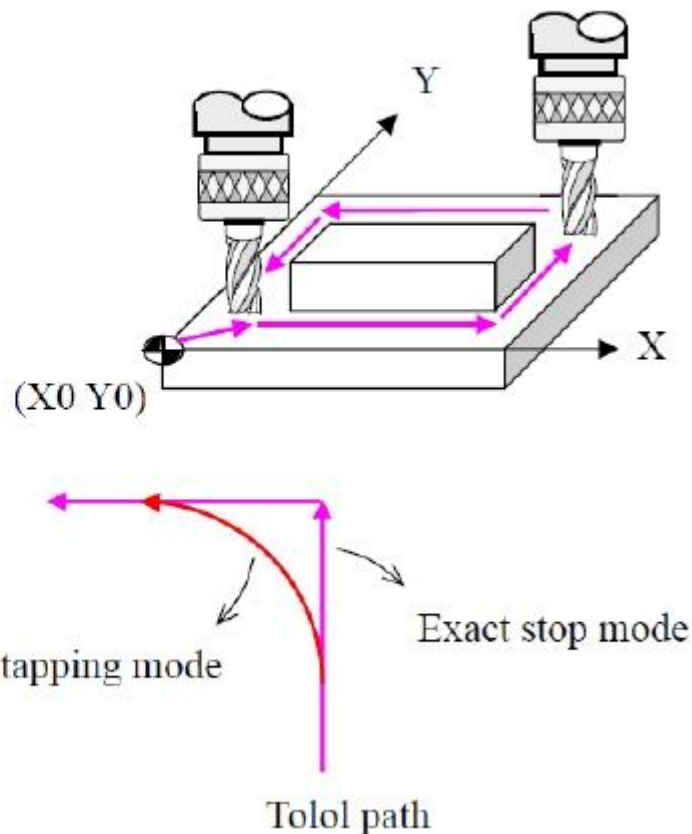

Note : Among the four commands of G61 exact stop mode / G62 automatic override for inner corners / G63 tapping mode / G64 cutting mode, anyone can replace another.

Automatic Override for Inner Corners (G62)

Use of the command :

It is used for cutting at the inner corner to get better cutting effect such as surface roughness, accuracy and extend the tool life.

Format :

G62 ;

Meaning of command :

G62 : Command directly. The relative information is set in parameter.

Example :

```
O1000 ;
:
G62 ;
G01 X-100. Y0 F100 ;
X-100.Y100. ;
:
:
M30 ;
```

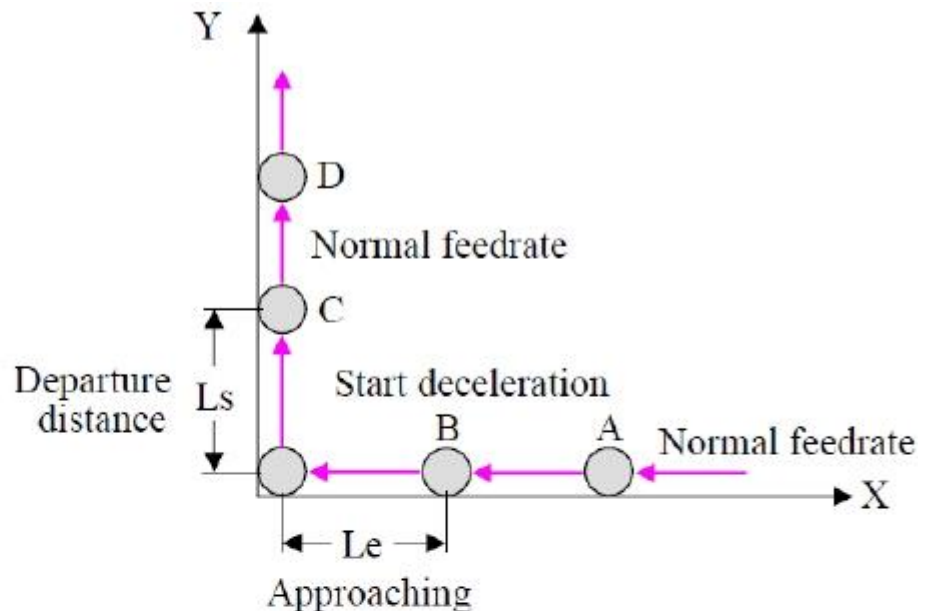

Parameter

No.	Meaning
1710	Minimum deceleration ratio of the inner circular cutting rate (mm/min)
1711	Angle used to recognize an inner corner (There is no deceleration when a cutting inner angle is bigger than this value.)
1712	Amount of override
1713	Distance Le from the starting point (Unit : 0.1mm)
1714	Distance Ls up to the ending point (Unit : 0.1mm)

Note : (1) Assume cutting is with feedrate F100 from point A to B and from C to D, and the percentage setting of the automatic override for inner corners is 50%. The cutting feedrate around the corner (from point B to C) will be $F = 100 \times 50 \% = 50\text{mm}/\text{min}$.

(2) If the angle of an inner corner is bigger than the set value, the function of the automatic override for inner corners will be not executed.

Tapping Mode (G63)

Use of the command :

During tapping mode, rotary switches of SPINDLE OVERRIDE %, FEEDRATE OVERRIDE % and the button of FEEDHOLD are ineffective.

Format :

G63 ;

Example :

O1000 ;

G80 G40 G49 G00 G17 ;

:

G63 ;

G84 Z-30. F300 ;

G80 ;

:

M30 ;

Note : (1) The tapping is treated with program internally in this CNC controller so that the tapping mode G63 will be applied automatically during tapping process and return the cutting mode G64 after the tapping process. Thus, the G63 can be omitted.

(2) G63 is ineffective under the status of DRY RUN. Be sure to pay attention to this.

Coordinate System Rotation (G68/69)

Use of the command :

It is used to rotate the coordinate system in the program with some angle in advance so as to simplify programming.

Format :

```
G68 X__ Y__ R__ ;  
G69 ;
```

Meaning of command :

G68 : Coordinate System Rotation ON.

G69 : Coordinate System Rotation OFF.

X, Y : The datum point of the rotated coordinate system.

R : Rotated angle.

Example :

```
O1000 ;
```

```
G80 G40 G49 G00 G17 ;
```

```
G00 G90 G54 X0 Y0 ;
```

```
G68 X0 Y0 R45. ; → Rotate 45° based on the datum point X0 Y0.
```

```
: }  
: } Cutting program
```

```
G69 ; → Coordinate system rotation OFF
```

```
:
```

```
M30 ;
```

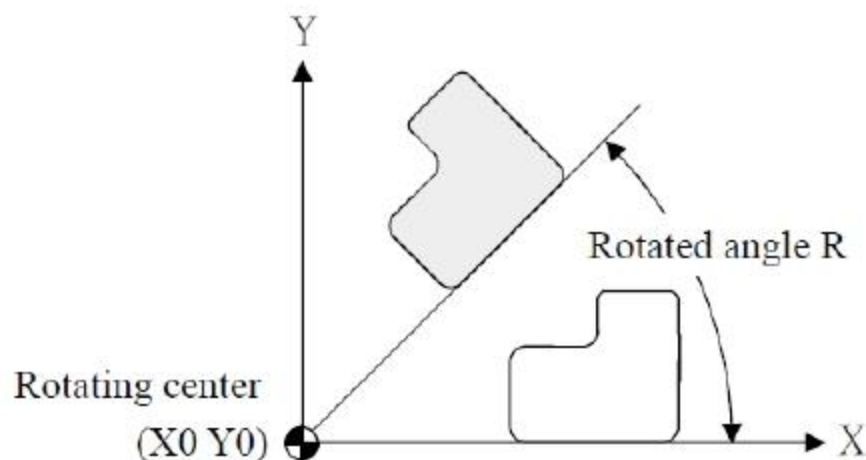

Parameter

No.	Meaning
5400 # 0	Coordinate rotation angle command (R) 0 : Specified by an absolute method 1 : Specified by an incremental method (G90 or G91)

Note : Commands G90/G91 are effective to the coordinates X_Y_ and ineffective to the R.

Canned Cycle (G73, G74, G76, G80~G89)

G Code	Drilling (-Z direction)	Operation at the bottom of a hole	Retraction (+Z direction)	Application
G73	Intermittent feed	—	Rapid traverse	High-speed peck drilling cycle
G74	Feed	Dwell → Spindle C.W	Feed	Left-hand tapping cycle
G76	Feed	Oriented spindle stop	Rapid traverse	Fine boring cycle
G80	—	—	—	Cancel
G81	Feed	—	Rapid traverse	Drilling cycle, spot drilling cycle
G82	Feed	Dwell	Rapid traverse	Drilling cycle, counter boring cycle
G83	Intermittent feed	—	Rapid traverse	Peck drilling cycle
G84	Feed	Dwell → Spindle C.C.W	Feed	Right-hand tapping cycle
G85	Feed	—	Feed	Boring cycle
G86	Feed	Spindle stop	Rapid traverse	Boring cycle
G87	Feed	Spindle C.W	Rapid traverse	Back boring cycle
G88	Feed	Dwell → Spindle stop	Manual	Boring cycle
G89	Feed	Dwell	Feed	Boring cycle

A canned cycle consists of six operations in sequence as follows.

Operation 1 : Positioning of axes X, Y and Z (Z axis at the initial point).

Operation 2 : Rapid traverse to the reference point R.

Operation 3 : Feed.

Operation 4 : Operation at the bottom of a hole.

Operation 5 : Retraction to the point R.

Operation 6 : Rapid traverse to the initial point.

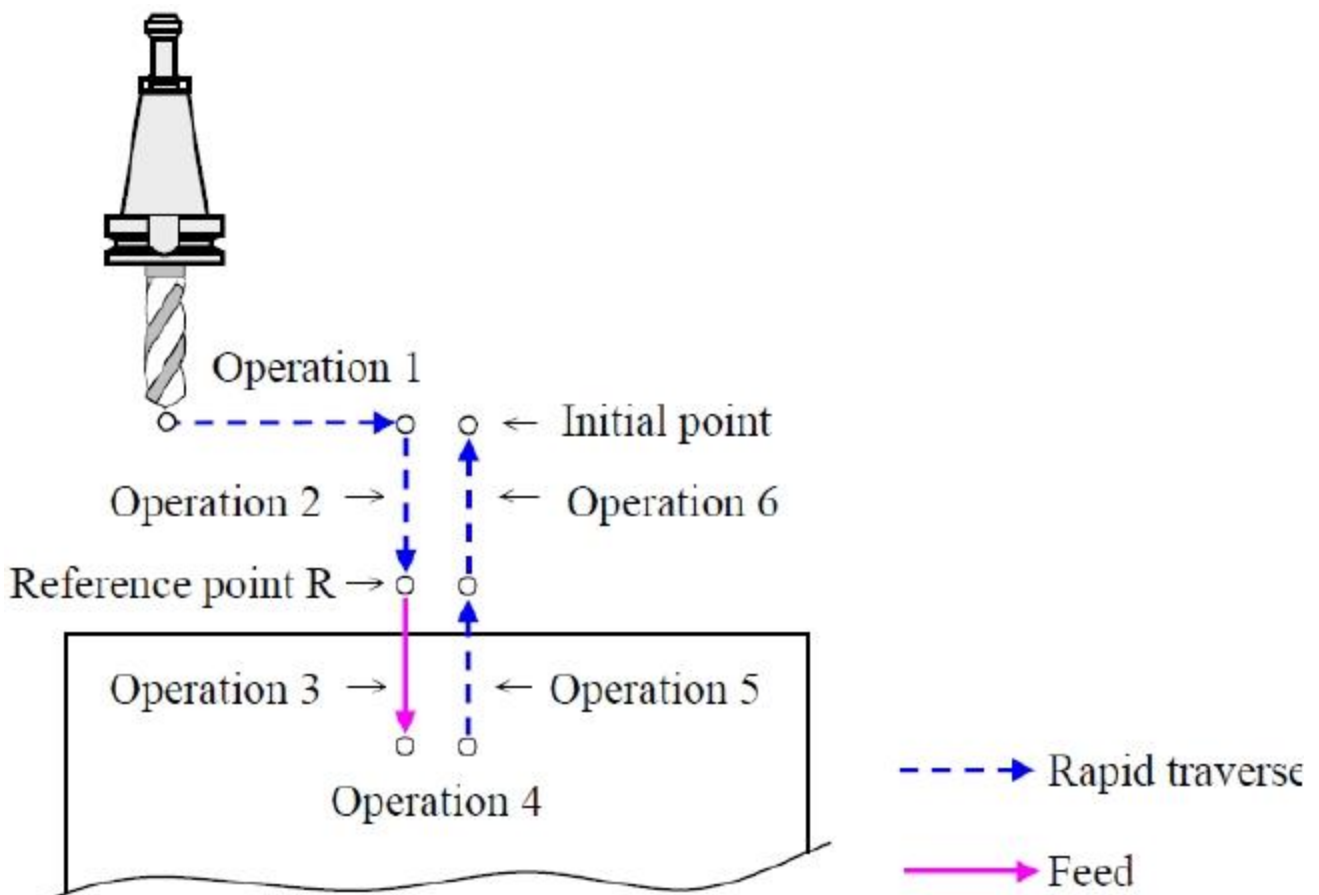

High Speed Peck Drilling Cycle (G73)

Use of the command :

It is used for deep drilling and a material of chips broken not easily. After work, use G80 to cancel this function.

Format :

(G98/G99) G73 X__ Y__ Z__ R__ Q__ F__ ;

Meaning of command :

- X, Y : Coordinates of a position.
- Z : Cutting depth
- R : Height of the reference point.
- Q : Cutting depth of each step.
- F : Feedrate

Example :

```
O1000 ;
G80 G40 G49 G00 G17 ;
G90 G54 X25. Y25. ;
G43 Z10. H01 M3 S1000 ;
G73 X50. Y50. Z-20. R5. Q6. F150 ;
G80 ;
:
M30 ;
```

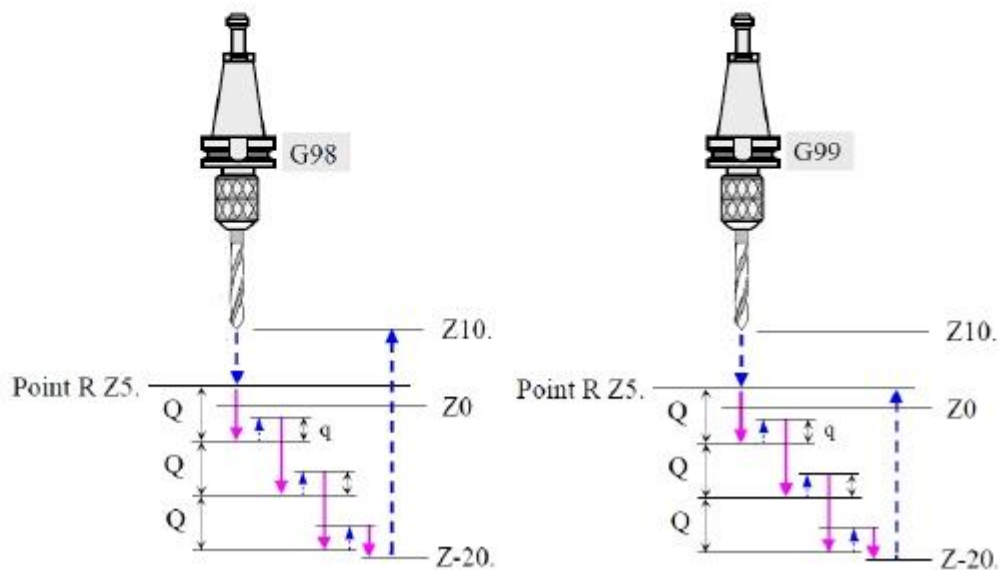

q : Returning height for each step

Parameter

No.	Meaning
5114	Return value of high speed peck drilling cycle (G73)

Note : (1) When clamping the tool in spindle, do spindle orientation M19 and then clamp the tool to the opposite direction that the tool is shifted at the hole bottom.

(2) The commands G90/G91 or G98/G99 can be used together.

(3) For the command G98/G99, please refer to the section of G98/G99 Retraction to the start point/reference point after cutting.

Counter Tapping Cycle (G74)

Use of the command :

It is used for tapping of left-hand thread. The tool will rotate with the opposite direction at the hole bottom automatically, and retracts out of the hole. After work, use G80 to cancel this function.

Format :

(G98/G99) G74 X__ Y__ Z__ R__ F__ ;

Meaning of command :

- X, Y : Coordinates of a position
- Z : Cutting depth
- R : Height of the reference point
- F : Feedrate

Example :

```
M10 × 1.5 P
O1000 ;
G80 G40 G49 G00 G17 ;
G90 G54 X25. Y25. ;
G43 Z10. H01 M4 S160 ;
G74 X50. Y50. Z-20. R5. F240 ;
G80 ;
:
M30 ;
```

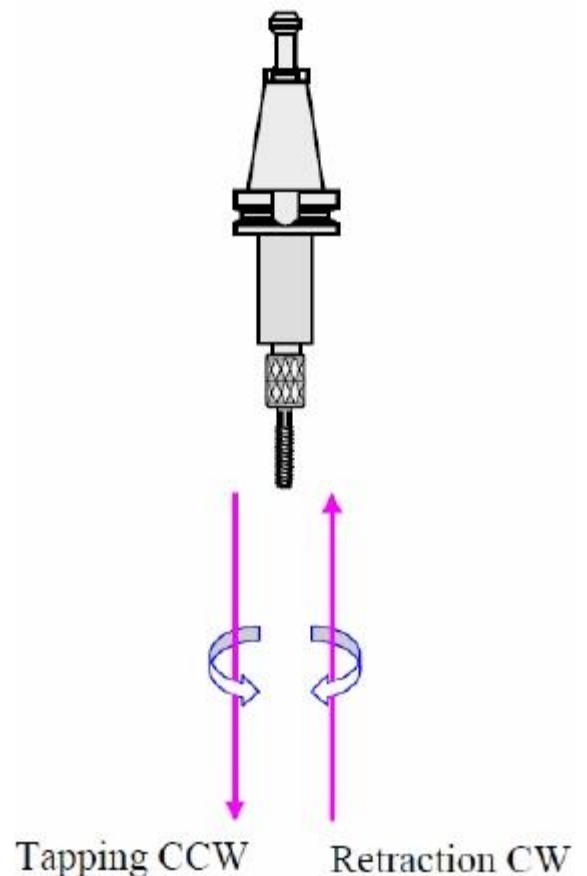

Note : (1) F (Feed) = P (Pitch) \times S (Spindle speed)

EX : $F = P \times S = 1.5 \times 160 = 240 \text{ mm/min}$

If the above formula is not followed, the tool or workpiece could be damaged.

- (2) When a tapping operation is needed during setting up a work, the function of DRY RUN has to be cancelled so as to avoid the tool or workpiece damaged.
- (3) For the command G98/G99, please refer to the section of G98/G99 Retraction to the start point/reference point after cutting.

Fine Boring Cycle (G76)

Use of the command :

It is used for finish boring without hurting the finished surface. After work, use G80 to cancel this function.

(Pay attention to the direction of the boring bar mounted.)

Format :

(G98/G99) G76 X__ Y__ Z__ R__ Q__ F__ ;

Meaning of command :

X, Y : Coordinates of a position.

Z : Cutting depth.

R : Height of the reference point.

Q : Tool shifted distance at the hole bottom.

F : Feedrate

Example :

O1000 ;

G80 G40 G49 G00 G17 ;

G90 G54 X25. Y25. ;

G43 Z10. H01 M3 S1200 ;

G76 X50. Y50. Z-20. R5. Q0.5 F100 ;

G80 ;

;

M30 ;

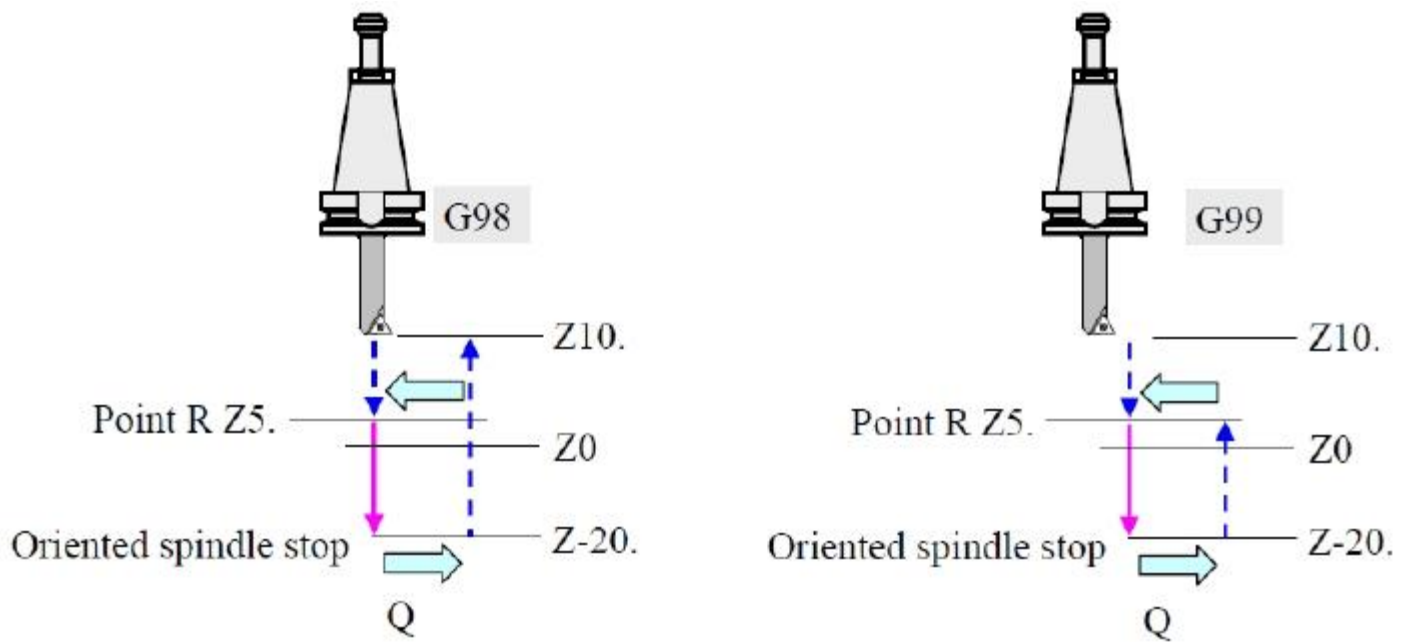

Q : Tool shifted amount.

Parameter

No.		Meaning		
5101 # 5	5101 # 4	G17	G18	G19
0	0	+X	+Z	+Y
0	1	-X	-Z	-Y
1	0	+Y	+X	+Z
1	1	-Y	-X	-Z

Note : (1) When clamping the tool in spindle, do spindle orientation M19 and then clamp the tool with the direction along the tool is shifted at the hole bottom.

(2) The command G90/G91 or G98/G99 can be used together.

(3) For the command G98/G99, please refer to the section of G98/G99 Retraction to the start point/ eference point after cutting.

Drilling Cycle, Spot Boring Cycle (G81)

Use of the command :

It is used for drilling a center hole or a shallow hole. After work, use G80 to cancel this function.

Format :

(G98/G99) G81 X__ Y__ Z__ R__ F__ ;

Meaning of command :

X, Y : Coordinates of a position

Z : Cutting depth

R : Height of the reference point

F : Feedrate

Example :

O1000 ;

G80 G40 G49 G00 G17 ;

G90 G54 X25. Y25. ;

G43 Z10. H01 M3 S1000 ;

G81 X50. Y50. Z-5. R5. F150 ;

G80 ;

:

M30 ;

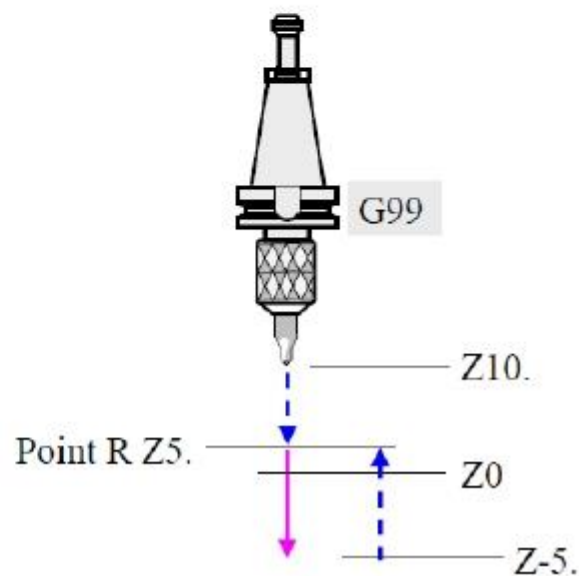
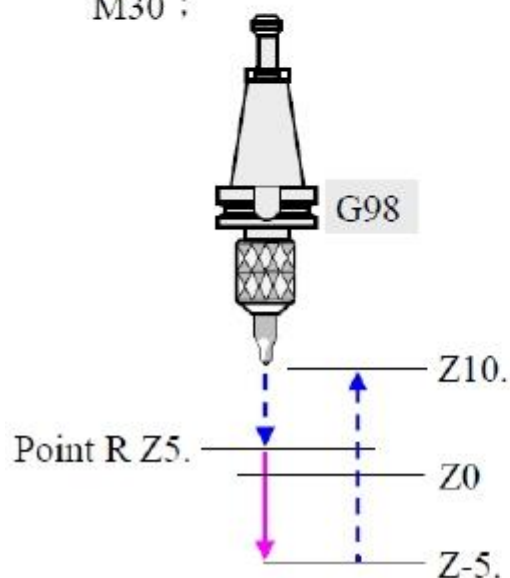

Note : (1) The G81 is a Modal G code. When drilling the first hole, the command G81 Z_F has to be written. Thereafter, if the Z, F are kept the same, specifying the X, Y coordinates is needed only for the other holes.

(2) The command G90/G91 or G98/G99 can be used together.

(3) For the command G98/G99, please refer to the section of G98/G99 Retraction to the start point/reference point after cutting.

Drilling Cycle or Counter Boring Cycle (G82)

Use of the command :

It is used for cutting a counterbore or reaming. After work, use G80 to cancel this function.

Format :

(G98/G99) G82 X__ Y__ Z__ R__ P__ F__ ;

Meaning of command :

X, Y : Coordinates of a position

Z : Cutting depth

R : Height of the reference point

P : Dwell time at the hole bottom (unit : 0.001sec.)

F : Feedrate

Example :

Cutting a counterbore/ countersink, dwell at the hole bottom for 0.5 seconds.

O1000 ;

G80 G40 G49 G00 G17 ;

G90 G54 X25. Y25. ;

G43 Z10. H01 M3 S1200 ;

G82 X50. Y50. Z-15. R5. P500 F100 ;

G80 ;

;

M30 ;

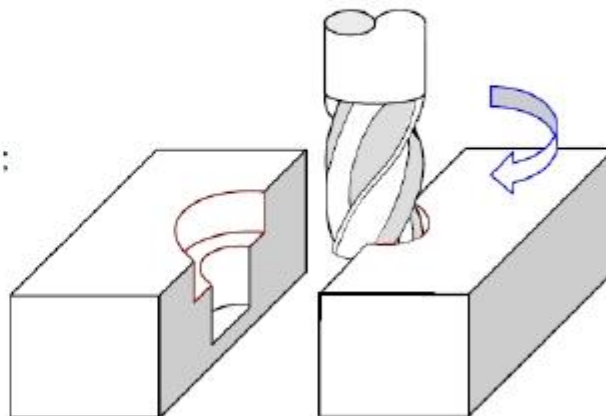

Dwell at the hole bottom for 0.5 seconds.

Note : (1) The G82 is a Modal G code. When drilling the first hole, the command G81 Z_F_P_ has to be written. Thereafter, if the Z, F, and P are kept the same, specifying the X, Y coordinates is needed only for the other holes.
(2) The command G90/G91 or G98/G99 can be used together.
(3) For the command G98/G99, please refer to the section of G98/G99 Retraction to the start point/reference point after cutting.

Peck Drilling Cycle (G83)

Use of the command :

It is used for drilling a deep hole. It is better for lubrication and cooling so that it is suitable for cutting a material broken not easily. After work, use G80 to cancel this function.

Format :

(G98/G99) G83 X__ Y__ Z__ R__ Q__ F__ ;

Meaning of command :

X, Y : Coordinates of a position

Z : Cutting depth

R : Height of the reference point

Q : Cutting depth of each step

F : Feedrate

Example :

O1000 ;

G80 G40 G49 G00 G17 ;

G90 G54 X25. Y25. ;

G43 Z10. H01 M3 S1000 ;

98 G83 X50. Y50. Z-20. R5. Q6. F150 ;

G80 ;

;

M30 ;

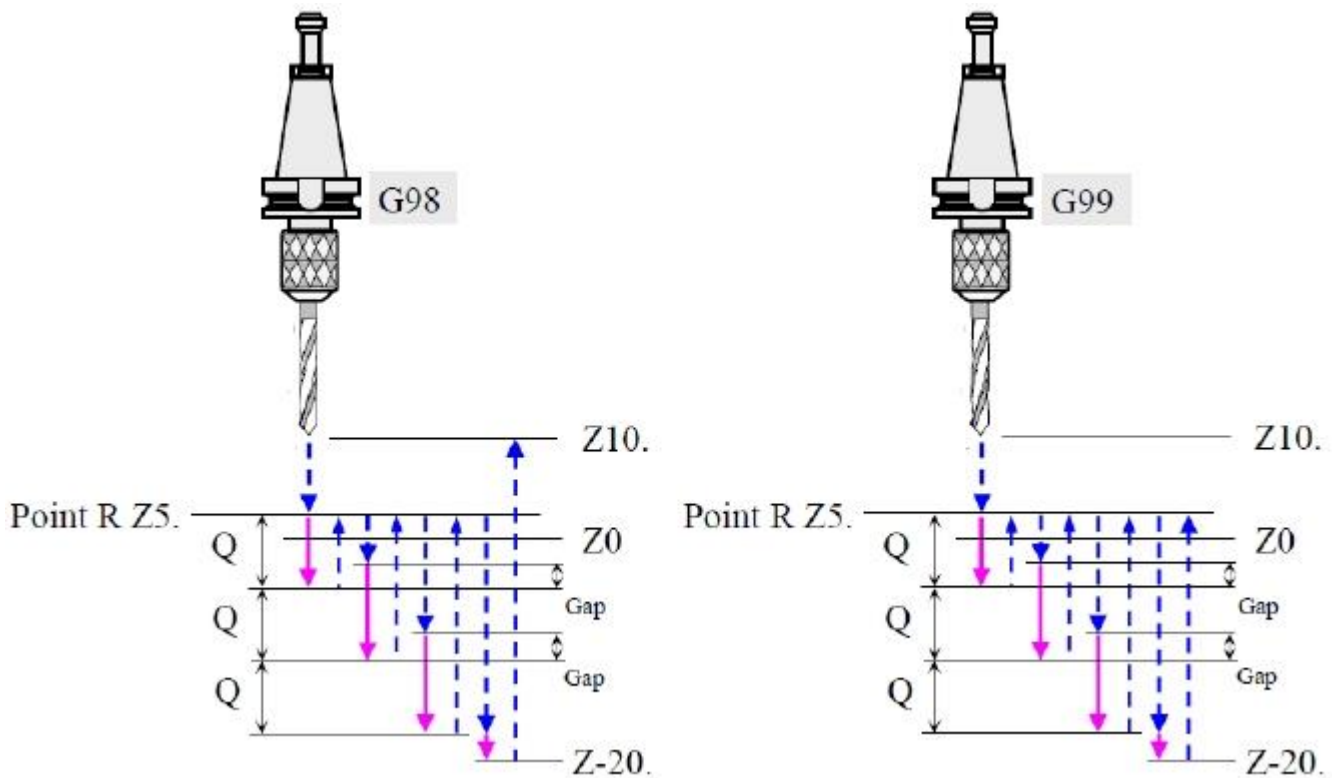

Parameter

No.	Meaning
5115	Clearance of canned cycle(G83)

Note : (1) This command cannot be used together with a command of Group 01 (such as G00, G01, G02). Otherwise, this function will be ineffective.
 (2) The command G90/G91 or G98/G99 can be used together.
 (3) For the command G98/G99, please refer to the section of G98/G99 Retraction to the start point/reference point after cutting.

Tapping Cycle (G84)

Use of the command :

It is used for tapping of right-hand thread. The tool will rotate with the opposite direction at the hole bottom automatically, and retract out of the hole. After work, use G80 to cancel this function.

Format :

(G98/G99) G84 X__ Y__ Z__ R__ F__ ;

Description on the format:

X, Y : Coordinates of a position

Z : Cutting depth

R : Height of the reference point

F : Feedrate

Example :

M10 × 1.5 P

O1000 ;

G80 G40 G49 G00 G17 ;

G90 G54 X25. Y25. ;

G43 Z10. H01 M3 S160 ;

G74 X50. Y50. Z-20. R5. F240 ;

G80 ;

:

M30 ;

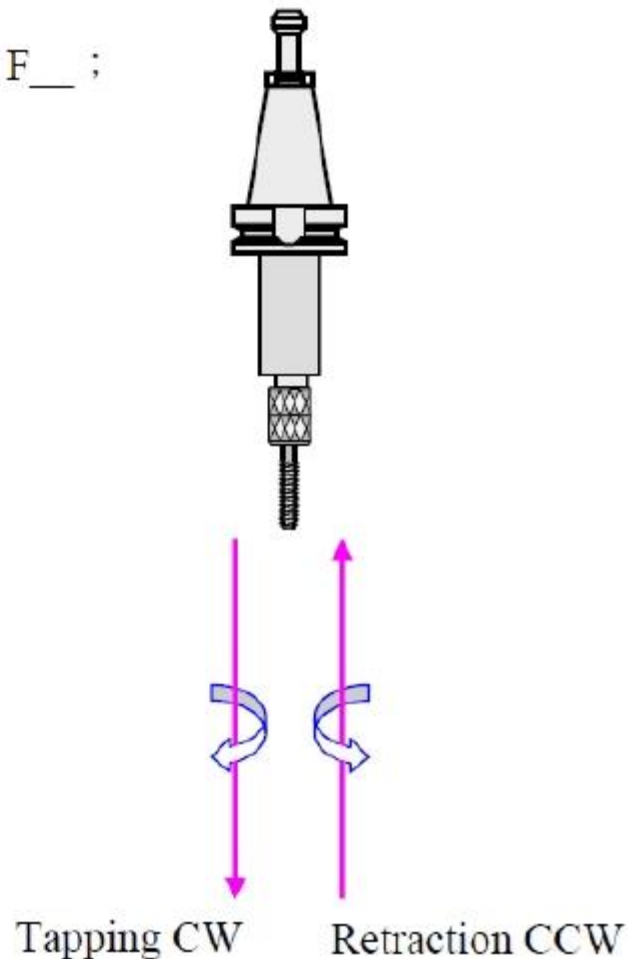

- Note :
- (1) This command cannot be used together with a command of Group 01 (such as G00, G01, G02). Otherwise, this function will be ineffective.
 - (2) This is a modal G code.
 - (3) F (Feed) = P (Pitch) × S (Spindle speed)
 - (4) When a tapping operation is done during setting up a work, the rotary switches of SPINDLE OVERRIDE % and FEEDRATE OVERRIDE % are ineffective.
 - (5) For the command G98/G99, please refer to the section of G98/G99 Retraction to the start point/reference point after cutting.

Boring Cycle (G85)

Use of the command :

It is used for rough boring or reaming. After work, use G80 to cancel this function.

Format :

(G98/G99) G85 X__ Y__ Z__ R__ F__ ;

Description on the format :

X, Y : Coordinates of a position

Z : Cutting depth

R : Height of the reference point

F : Feedrate

Example :

O1000 ;

G80 G40 G49 G00 G17 ;

G90 G54 X25. Y25. ;

G43 Z10. H01 M3 S1000 ;

G85 X50. Y50. Z-20. R5. F150 ;

G80 ;

;

M30 ;

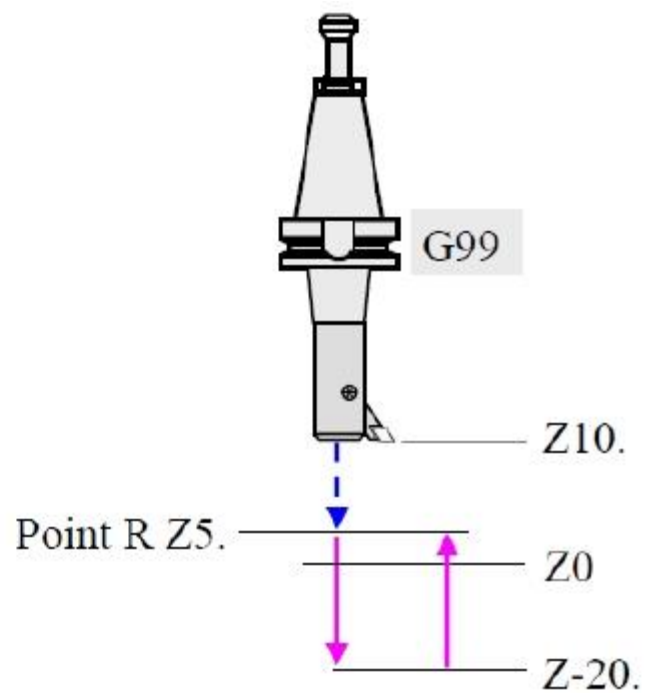
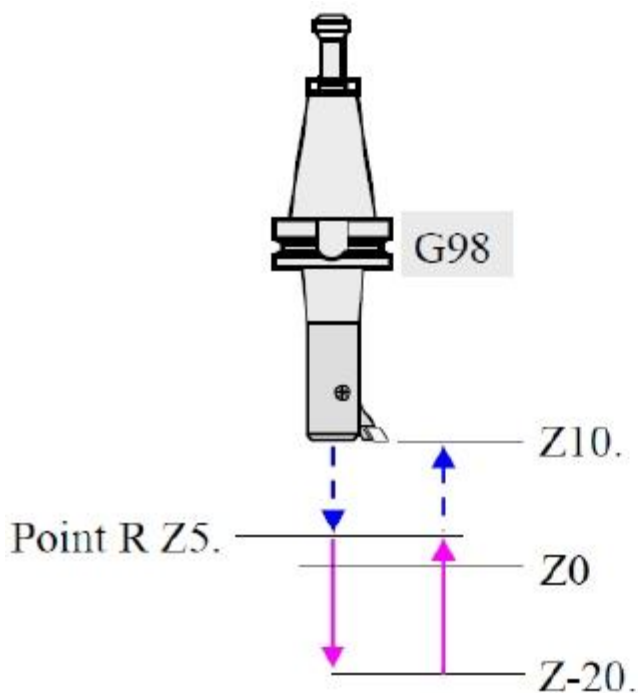

Note : (1) The spindle doesn't stop at the hole bottom and retracts out of the hole with the feedrate F.

(2) The command G90/G91 or G98/G99 can be used together.

(3) For the command G98/G99, please refer to the section of G98/G99 Retraction to the start point/reference point after cutting.

Boring Cycle (G86)

Use of the command :

It is used for rough boring or reaming. After work, use G80 to cancel this function.

Format :

(G98/G99) G86 X__ Y__ Z__ R__ F__ ;

Description on the format :

X, Y : Coordinates of a position

Z : Cutting depth

R : Height of the reference point

F : Feedrate

Example :

```
O1000 ;  
G80 G40 G49 G00 G17 ;  
G90 G54 X25. Y25. ;  
G43 G0 Z10. H01 M3 S1000 ;  
G98 G86 X50. Y50. Z-20. R5. F150 ;  
G80 ;  
;  
M30 ;
```

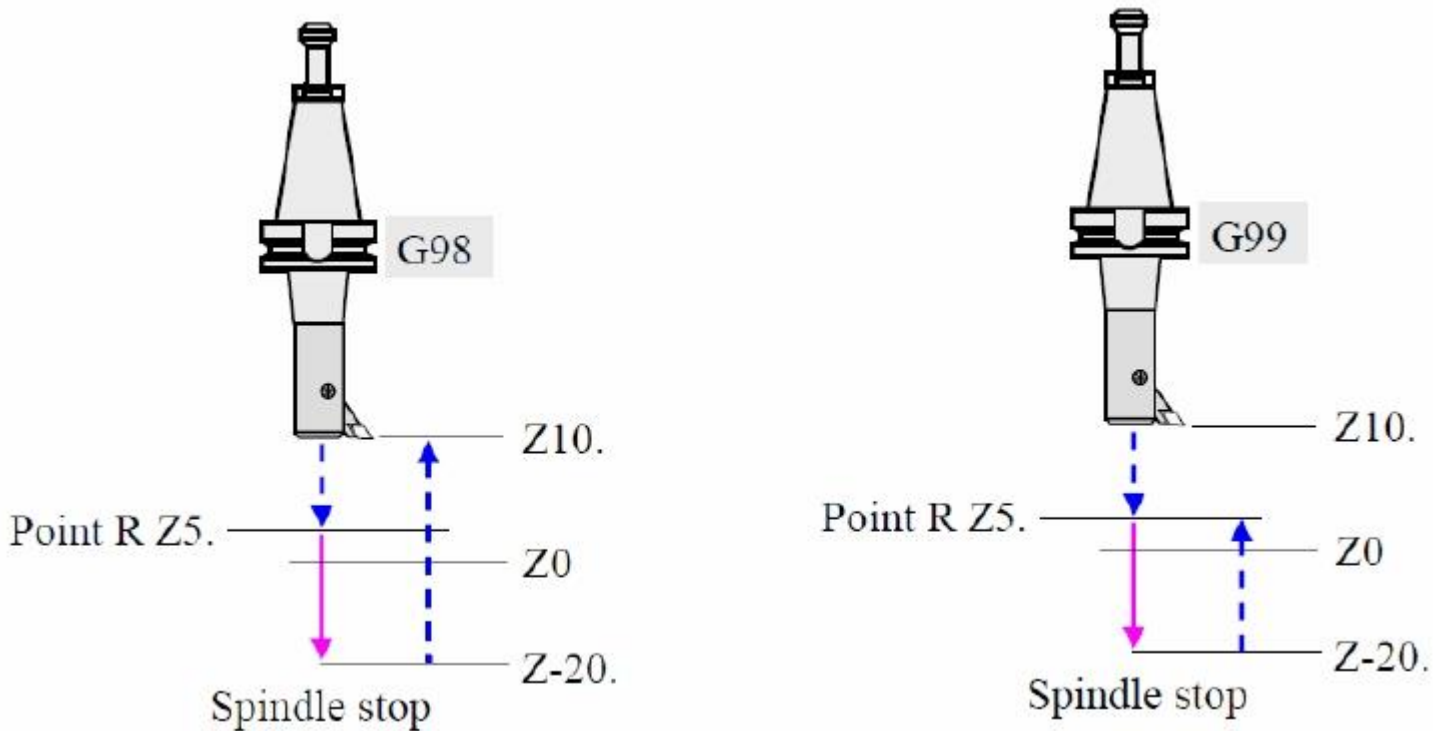
- Note :
- (1) This command cannot be used together with a command of Group 01 (such as G00, G01, G02). Otherwise, this function will be ineffective.
 - (2) The spindle stops and does orientation at the hole bottom. It retracts out of the hole with G00, and then rotates again.
 - (3) The command G90/G91 or G98/G99 can be used together.
 - (4) For the command G98/G99, please refer to the section of G98/G99 Retraction to the start point/reference point after cutting.

Back Boring Cycle (G87)

Use of the command :

It is used for boring from the back side. After work, use G80 to cancel this function. **(Pay attention to the direction of the boring bar mounted.)**

Format :

(G98) G87 X__ Y__ Z__ R__ Q__ F__ ;

Meaning of command :

- X, Y : Coordinates of a position
- Z : Cutting depth
- R : Height of the reference point
- Q : Tool shifted amount
- F : Feedrate

Example :

```
O1000 ;
G80 G40 G49 G00 G17 ;
G90 G54 X25. Y25. ;
G43 Z10. H01 M3 S1000 ;
G87 X50. Y50. Z-10. R-15. Q1. F150 ;
G80 ;
:
M30 ;
```

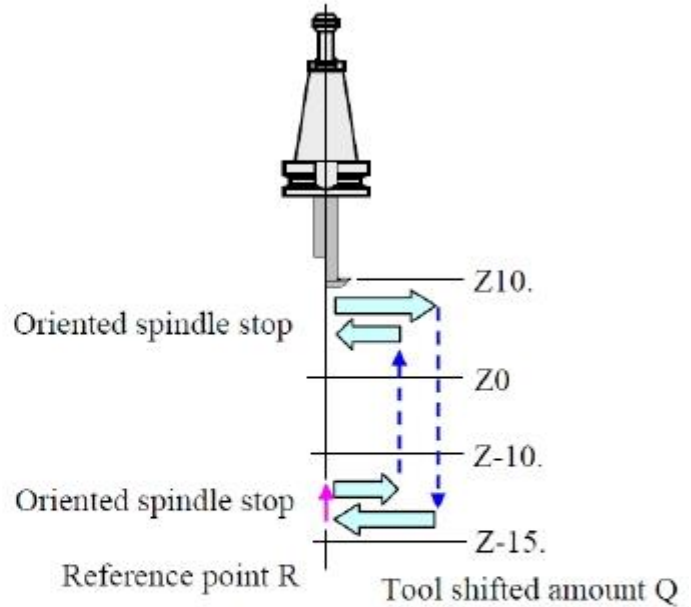

Parameter

No.		Meaning		
5101 # 5	5101 # 4	G17	G18	G19
0	0	+X	+Z	+Y
0	1	-X	-Z	-Y
1	0	+Y	+X	+Z
1	1	-Y	-X	-Z

Note : The operation of this code G87 is explained as follows.

- (1) When the tool is at the position Z10, spindle stops and does orientation. Then it shifts for 1 mm from the center position along the opposite direction of tool tip.
- (2) Spindle moves down to the position Z-15. with G00 and shifts back to the center position.
- (3) At this moment, spindle start rotation and bores from the back side to the position Z-10 with the feedrate F150.
- (4) At the position Z-10, spindle stops and does orientation, shifts for 1mm from the center position again and then retracts to the position Z10 with G00.
- (5) Spindle shifts back to the center point and start rotation again.

Boring Cycle (G88)

Use of the command :

It is used for boring with feed hold at the hole bottom. The tool retracts out of the hole by pressing the button CYCLE START. After work, use G80 to cancel this function.

Format :

(G98/G99) G88 X__ Y__ Z__ R__ F__ ;

Meaning of command :

- X, Y : Coordinates of a position
- Z : Cutting depth
- R : Height of the reference point
- F : Feedrate

Example :

O1000 ;

G80 G40 G49 G00 G17 ;

G90 G54 X25. Y25. ;

G43 Z10. H01 M3 S1000 ;

G88 X50. Y50. Z-20. R5. F150 ;

G80 ;

;

M30 ;

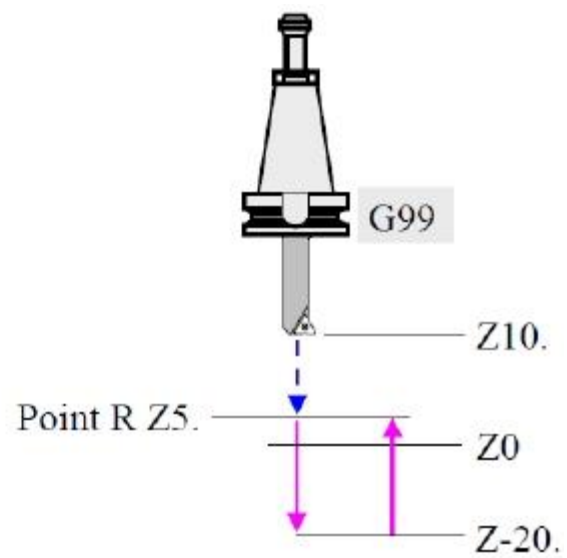
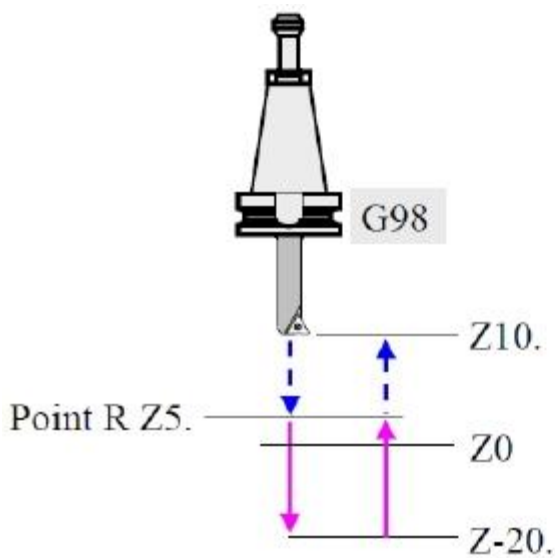

Feed hold at the hole bottom and spindle stops.

The button CYCLE START  must be pressed and then spindle rotates again and retracts out of the hole.

Boring Cycle (G89)

Use of the command :

It is used for boring with feed hold for a specified time at the hole bottom such as boring a blind hole. After work, use G80 to cancel this function.

Format :

(G98/G99) G88 X__ Y__ Z__ R__ P__ F__ ;

Meaning of command :

X, Y : Coordinates of a position

Z : Cutting depth

R : Height of the reference point

P : Feed hold time at hole bottom (unit : 0.001sec.)

F : Feedrate

Example :

O1000 ;

G80 G40 G49 G00 G17 ;

G90 G54 X25. Y25. ;

G43 Z10. H01 M3 S1000 ;

G89 X50. Y50. Z-20. R5. P1000 F150 ;

G80 ;

;

M30 ;

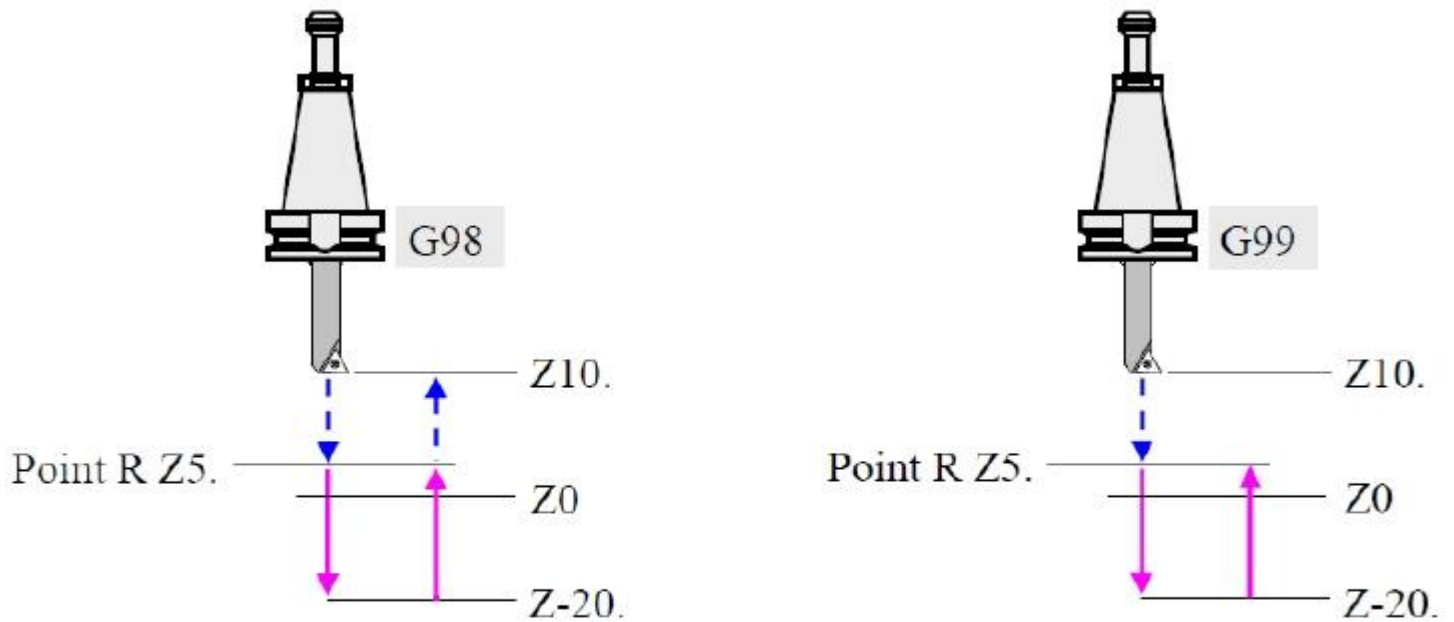

Feed hold time P
at the hole bottom.

Absolute and Increment Command (G90/G91)

Use of the command :

They are used for specifying the calculation and execution about commands of position and angle with absolute type (relative to the work origin) or incremental type (relative to the current position).

Format :

G90 ;

G91 ;

Meaning of command :

G90 : Absolute mode.

G91 : Incremental mode.

G90/G91 can be used single or together with other commands in a block.

Example :

(G90 Absolute mode)

O1000 ;

G90 G00 X0 Y0 ; → Start from the work origin

X50. Y0 ;

X50. Y50. ;

X100. Y100. ;

M30 ;

Or

(G91 Incremental mode)

O2000 ;

G91 G00 X50. Y0 ; → Start from the work

X0 Y50. ;

X50. Y50. ;

M30 ;

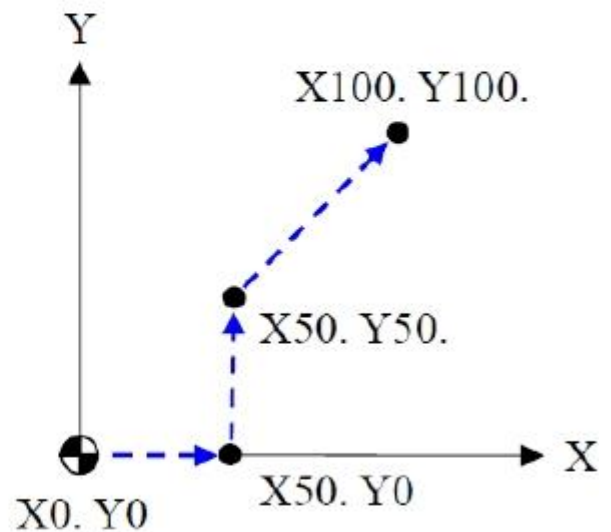

Hint : Look the current position as the work origin at this moment.

Note : (1) The above two examples are the same work paths. The comparison to each other is the difference of the path programming.

(2) G90 / G91 are both modal G codes.

(3) Usually, the G90 is used in the main program and G91 in the subprogram. However, there are still some exceptions. The major principle of such code selection is to simplify programming.

Setting for Work Coordinate System (G92)

Use of the command :

This command is similar to the G54~G59 (work coordinate system) and used for setting a work origin. In the program, the G92 can't be used with any of G54~G59 together. Otherwise, the coordinate system will be shifted away.

Format :

G90 G92 X__ Y__ Z__ ;

Meaning of command :

X, Y, Z : Set the current position as the absolute coordinates specified with the X, Y, Z values.

Example :

(1)

O1000 ;

G80 G40 G49 G00 G17 ;

G91 G28 Z0 ;

G28 X0 Y0 ; → At the machine origin

G91 G00 X-321. Y-123. ; → Set the work origin at this moment.

G90 G92 X0 Y0 ;

;

M30 ;

Note : After the tool returns the machine origin, it moves with incremental type to the position (X-321., Y-123.). Then, set that position as the origin of the absolute coordinate system. This is the work origin.

```
(2)
O2000 ;
G80 G40 G49 G00 G17 ;
G91 G28 Z0 ;
G28 X0 Y0 ; → At the machine origin
G90 G92 X321. Y123. ; → Set the work origin at this moment.
:
M30 ;
```

Note : When the tool returns the machine origin, and this position is the (X321., Y123.) in the absolute coordinate system. Then, the work origin can be confirmed.

Return to Initial Point or R Point in Canned Cycle (G98/G99)

Use of the command :

It is used for assisting the command of drilling cycle.

Format :

G98/G99 R__ ;

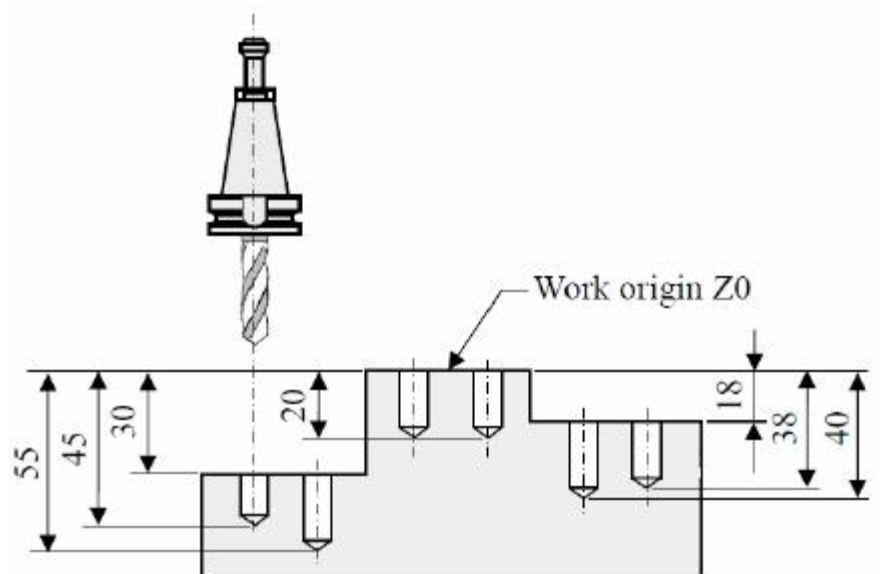

Example :

```

O1000 ;
G80 G40 G49 G00 G17 ;
G90 G54 X18. Y20. ;
G43 Z5. H01 M3 S800 ;
G99 G81 Z-45. R-28. F120 ;
G98 X35. R2. Z-55. ;
G99 X62. Z-20. ;
X84. ;
X114. R-16. Z-40. ;
X132. Z-38. ;
G80 ;
G91 G0 G28 Z0 M5 ;
M30 ;
    
```

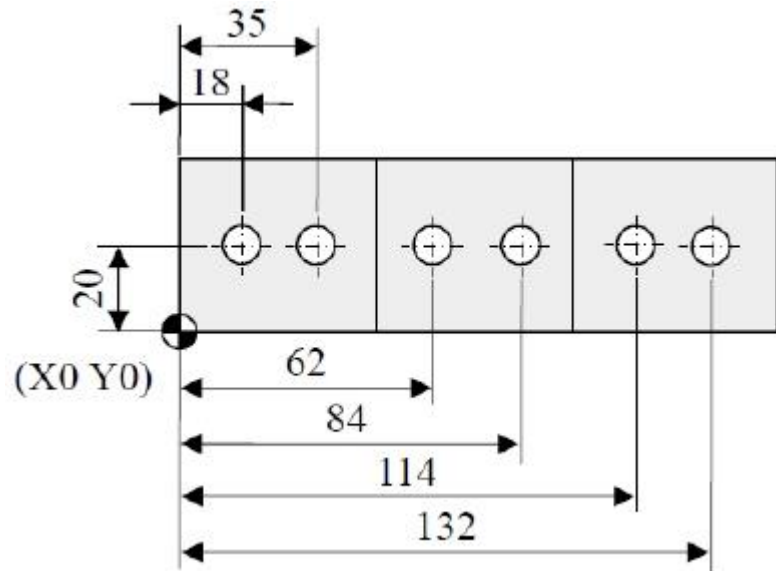

Note : (1) No matter which is G98/G99, tool must move rapidly to the reference point and then executing cutting. The returning height after cutting is decided by the G98/G99.

(2) Regarding the starting height, it is the last position just before the drilling cycle executed, e.g., the Z5. in the above example.

Chapter 5

Program Input / Output Operation

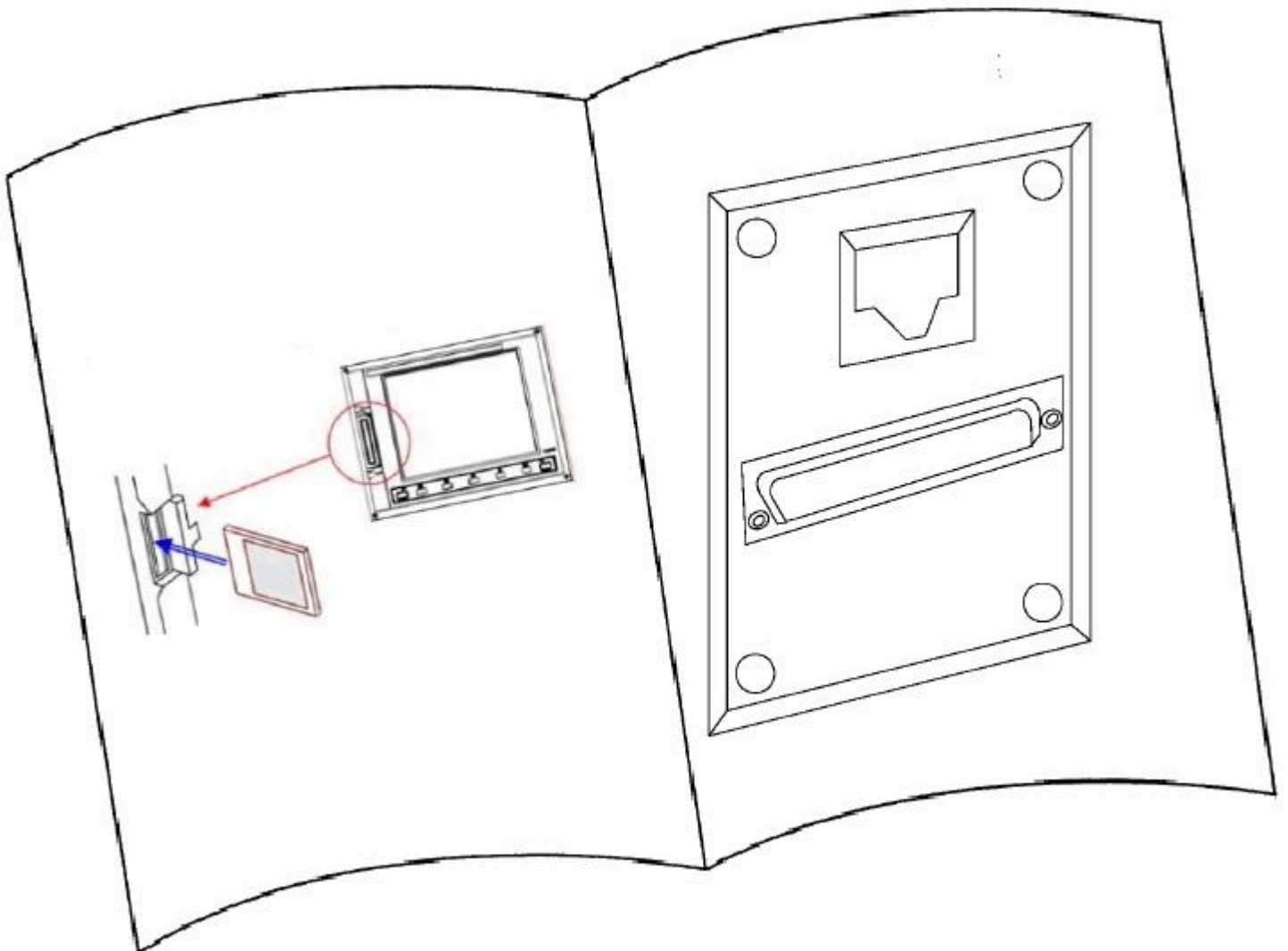

1. Memory Card Operation

NC data (ex. program, offset data, workpiece coordinate system data, etc.) can be read into the CNC from a Memory Card (upload) and written from the CNC to the Memory Card download).

It is necessary to set the I/O channel (the parameter No.20) as 4 on setting screen.

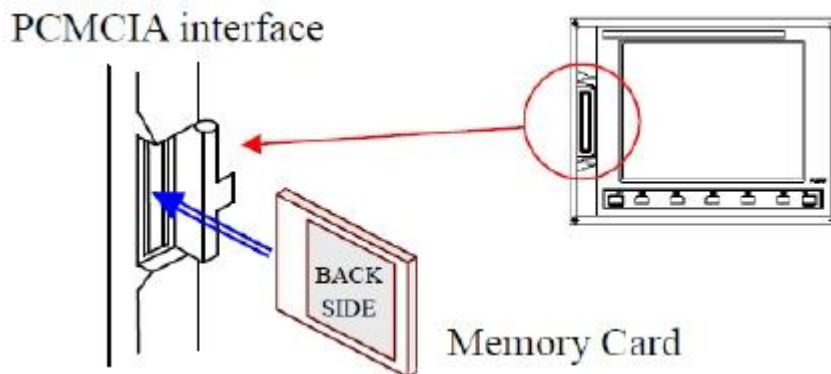

1.1 Displaying the Directory

1. Under the EDIT mode, press the function key **PROG**.
2. Press the rightmost soft key **▶** (continuous menu key).
3. Press the soft key **[CARD]**.

DIRECTORY (M-CARD)				00002 N00000	
NO.	FILE NAME	SIZE	DATE		
0009	PITCHERR. DAT	14342	02-11-27		
0010	PROGRAM. ALL	260	02-11-27		
0011	O8888. TXT	839147	01-10-29		
0012	O3400	884	02-11-08		
0013	WORK-G54. DAT	3054	02-11-27		
0014	O2183. TXT	3225101	02-11-22		
0015	IB1KR01	131200	02-11-27		
0016	YCM31. TXT	839147	01-10-29		
0017	HORSE. TXT	5657	00-04-10		



S 0 T0000

EDIT ****	***	***	12:31:08	
PRGRM		DIR +		(OPRT)

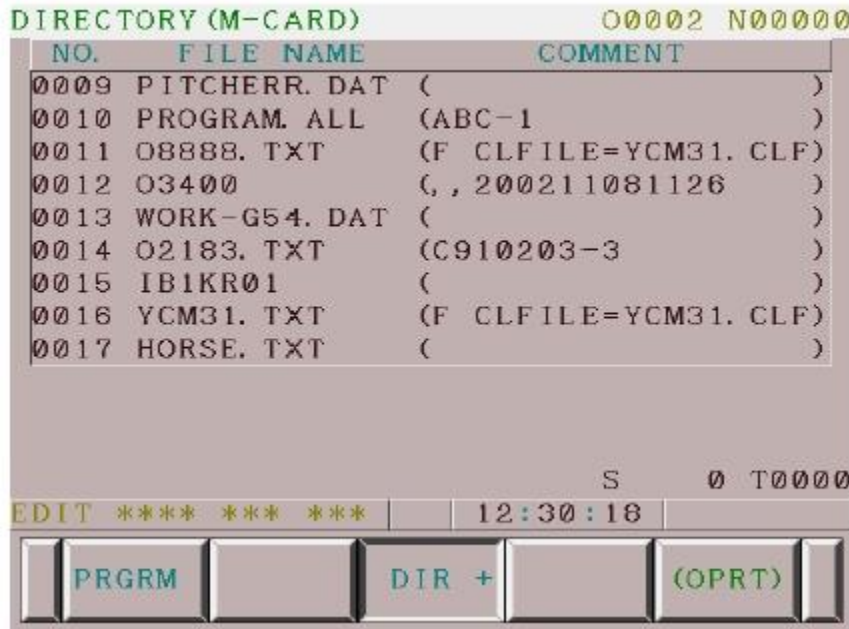
Comments relating to each file can be displayed by pressing the soft key [DIR +]. Up to 18 characters can be displayed on the screen.



1.2 Searching for a File

1. Under the EDIT mode, press the function key .
2. Press the rightmost soft key  (continuous menu key).
3. Press the soft key [CARD].
4. Press the soft key [DIR +].
5. Press the soft key [(OPRT)].
6. Press the soft key [F SRH].
7. Enter < the file number (No.) >.

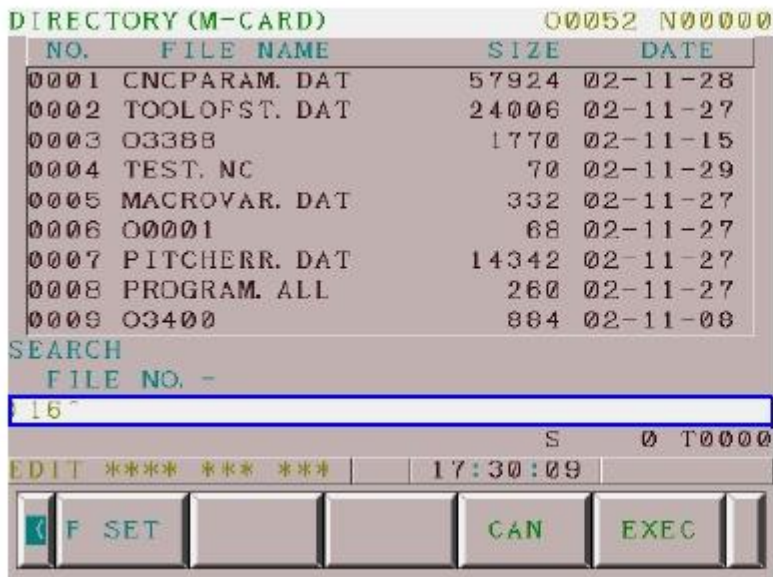



8. Press the soft key [F SET].

9. Press the soft key [EXEC] to execute.



10. Or press the soft key [CAN] to cancel this operation.

1.3 Reading a File

1. Under the EDIT mode, press the function key .
2. Press the rightmost soft key  (continuous menu key).
3. Press the soft key [CARD].
4. Press the soft key [DIR +].
5. Press the soft key [(OPRT)].
6. Path1. To specify a program number consisting of the address O.
 - (1) Press the soft key [F READ].
 - (2) Enter < the file number (No.) >.
 - (3) Press the soft key [F SET].

If the file No. of the read file will be changed, do the step nos. (4) and (5).

- (4) Enter < the new program number >.
- (5) Press the soft key [O SET].

DIRECTORY (M-CARD)		O0002 N00000	
NO.	FILE NAME	SIZE	DATE
0001	CNCPARAM. DAT	57924	02-11-28
0002	TOOLOFST. DAT	24006	02-11-27
0003	O3388	1770	02-11-15
0004	TEST. NC	70	02-11-29
0005	MACROVAR. DAT	332	02-11-27
0006	O0001	68	02-11-27
0007	PITCHERR. DAT	14342	02-11-27
0008	PROGRAM. ALL	260	02-11-27
0009	O3400	884	02-11-08

READ

FILE NO. = 6 PROGRAM NO. = 2002

EDIT **** * 16:36:16

[F SET] [O SET] [STOP] [CAN] [EXEC]

The No.6 O0001 is read and its file name is changed as O2002.

Path2. To specify a file with its file name.

- (1) Press the soft key [N READ].
- (2) Enter < the file name >.
- (3) Press the soft key [F NAME].

If the file No. of the read file will be changed, do the step nos. (4) and (5).

- (4) Enter < the new program number >.
- (5) Press the soft key [O SET].

DIRECTORY (M-CARD)		O0002 N00000	
NO.	FILE NAME	SIZE	DATE
0001	CNCPARAM. DAT	57924	02-11-28
0002	TOOLOFST. DAT	24006	02-11-27
0003	O3388	1770	02-11-15
0004	TEST. NC	70	02-11-29
0005	MACROVAR. DAT	332	02-11-27
0006	O0001	68	02-11-27
0007	PITCHERR. DAT	14342	02-11-27
0008	PROGRAM. ALL	260	02-11-27
0009	O3400	884	02-11-08

READ FILE NAME=TEST. NC
PROGRAM NO. = 1234

EDIT **** * 16:51:46



[F NAME] [O SET] [STOP] [CAN] [EXEC]

The No.4 TEST. NC is read and its file name is changed as O1234.

If no program No. Oxxxx is edited in the document, and no new program No. is specified either, it will be named as O0001 automatically.

7. Press the soft key [EXEC] to execute.
8. Or press the soft key [CAN] to cancel this operation.
9. Or press the soft key [STOP] to stop this operation.

1.4 Writing Files

1. Under the EDIT mode, press the function key .
2. Press the rightmost soft key  (continuous menu key).
3. Press the soft key [CARD].
4. Press the soft key [DIR +].
5. Press the soft key [(OPRT)].
6. Press the soft key [PUNCH].
7. Path1. Output a single file.

Enter < the program number >.

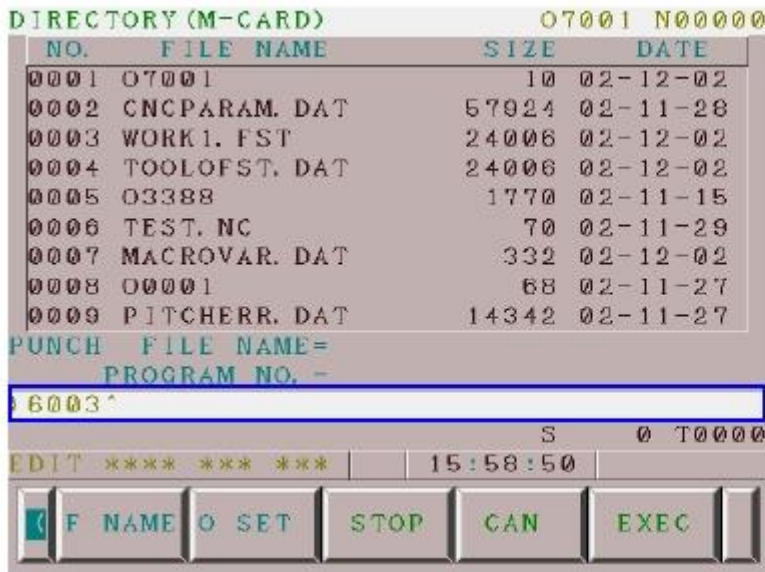

Output the program
O6003 in the NC
memory.

Path2. Output all programs stored.

Enter < -9999 >.



Output all programs
stored.

Path3. Output multiple programs.

Enter < the first program number > and press the MDI keys **SHIFT** **I** ,

then enter < the last program number >.

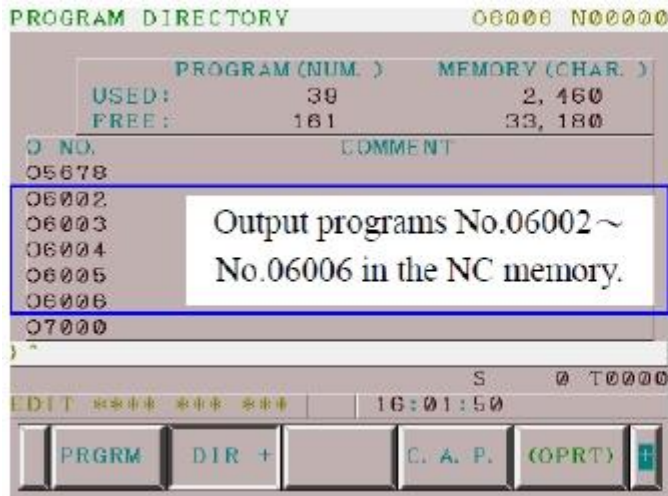

8. Press the soft key [O SET].

If the file name will be changed, do the step nos. 9 and 10.

9. Enter < the file name >.

If no file name is specified when writing all programs or multiple programs, the file name **PROGRAM.ALL** is used for registration.

10. Press the soft key [F NAME].

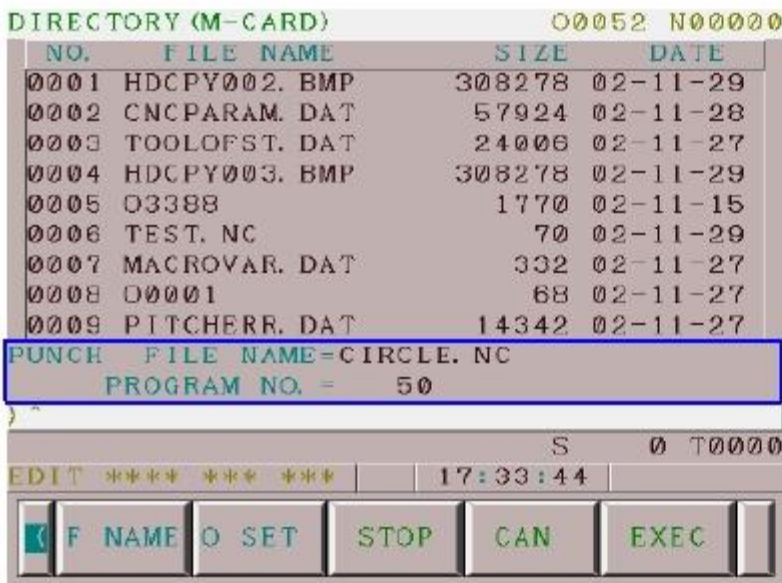

The program 00050 in the NC memory is output and then, its file name is changed as CIRCLE. NC.

11. Press the soft key [EXEC] to execute.
12. Or press the soft key [CAN] to cancel this operation.
13. Or press the soft key [STOP] to stop this operation.

Note : (1) When a file is with the same name already registered in the Memory Card, the existed file will be overwritten.

(2) File name is not longer than 8 characters, and extension not longer than 3 characters.

1.5 Deleting a File

1. Under the EDIT mode, press the function key **PROG**.
2. Press the rightmost soft key **▶** (continuous menu key).
3. Press the soft key [CARD].
4. Press the soft key [DIR +].
5. Press the soft key [(OPRT)].
6. Press the soft key [DELETE].
7. Enter < the file number (No.) >.

DIRECTORY (M-CARD)				00050	N00000
NO.	FILE NAME	SIZE	DATE		
0009	TEST. NC	70	02-11-29		
0010	MACROVAR. DAT	332	02-11-27		
0011	00001	68	02-11-27		
0012	PITCHERR. DAT	14342	02-11-27		
0013	PROGRAM. ALL	260	02-11-27		
0014	08888. TXT	839147	01-10-29		
0015	03400	884	02-11-08		
0016	WORK-G54. DAT	3054	02-11-27		
0017	HDCPY005. BMP	308278	02-11-29		

DELETE
FILE NO. =
) 15 ^

S 0 T0000

EDIT **** * * * *	12:42:39		
F SET		CAN	EXEC



8. Press the soft key [F SET].
9. Press the soft key [EXEC] to execute.
10. Or press the soft key [CAN] to cancel this operation.

1.6 DNC Operation

DNC operation with Memory Card is a function which is possible to perform machining with executing the program in the Memory Card.

It is necessary to set the parameter No.138 # 7 (the function of DNC operation with Memory Card) as 1 on setting screen.

1.6.1 Searching for a File

1. Under the TAPE mode, press the function key .
2. Press the rightmost soft key  (continuous menu key).
3. Press the soft key [DNC - CD].

DNC OPERATION (M-CARD)				00052 N01000	
NO.	FILE NAME	SIZE	DATE		
0020	00008	90	02-11-29		
0021	02183.TXT	3225101	02-11-22		
0022	1B1KR01	131200	02-11-27		
0023	YCM31.TXT	839147	01-10-29		
0024	HORSE.TXT	5657	00-04-10		
0025	12B.NC	2237	98-07-06		
0026	12A.NC	425	98-07-06		
0027	12C.NC	80368	98-07-06		
0028	12D.NC	1038698	98-07-06		

DNC FILE NAME :

) ^

S 0 T0000

RMT **** ** *

15:10:46



HD-DIR	HOST	CONNECT	DNC-CD	(OPRT)	+
--------	------	---------	--------	--------	---

4. Press the soft key [(OPRT)].
5. Enter < the file number (No.) >.



6. Press the soft key [F SRH].

1.6.2 Executing a File

1. Under the TAPE mode, press the function key .
2. Press the rightmost soft key  (continuous menu key).
3. Press the soft key [DNC - CD].
4. Press the soft key [(OPRT)].
5. Enter < the file number (No.) >.

DNC OPERATION (M-CARD)				00052 N01000	
NO.	FILE NAME	SIZE	DATE		
0020	00008	90	02-11-29		
0021	02183.TXT	3225101	02-11-22		
0022	1B1KR01	131200	02-11-27		
0023	YCM31.TXT	839147	01-10-29		
0024	HORSE.TXT	5657	00-04-10		
0025	12B.NC	2237	98-07-06		
0026	12A.NC	425	98-07-06		
0027	12C.NC	80368	98-07-06		
0028	12D.NC	1038698	98-07-06		

DNC FILE NAME : 00008

) ^

S 0 T0000

RMT **** ** *

15:10:46

[F SRH] [] [] [] [DNC-ST]



6. Press the soft key [DNC-ST].





7. Press the button CYCLE START  on the machine operating panel.

2. DATA INPUT/OUTPUT ON THE ALL IO SCREEN (USING MEMORY CARD)

It is necessary to operate under the EDIT mode and to set the I/O channel (the parameter No.20) as 4 on setting screen.



2.1 Program Input/Output

1. Under the EDIT mode, press the function key .
2. Press the rightmost soft key  (continuous menu key).
3. Press the soft key [ALL IO].
4. Press the soft key [PRGRM].

5. The directory is divided as Memory Card file directory and NC program directory. Use the cursor moving keys   to select the file in the directory. The mark * at the left side will move by following the selection. Then, use the page changing keys   to change the displayed page.



2.1.2 Searching for a File



1. Under the EDIT mode, press the function key .
2. Press the rightmost soft key  (continuous menu key).

3. Press the soft key [ALL IO].
4. Press the soft key [PRGRM].
5. Press the soft key [(OPRT)].
6. Press the soft key [F SRH].
7. Enter < the file number (No.) >.



8. Press the soft key [F SET].
9. Press the soft key [EXEC] to execute.
10. Or press the soft key [CAN] to cancel this operation.

2.1.3 Inputting a Program

1. Under the EDIT mode, press the function key .
2. Press the rightmost soft key  (continuous menu key).
3. Press the soft key [ALL IO].
4. Press the soft key [PRGRM].
5. Press the soft key [(OPRT)].
6. Path1. (1) Press the soft key [F READ].

(2) Enter < the program number (No.) >.

(3) Press the soft key [F SET].

If the file No. of the new program will be changed, do the step nos. (4) and (5).

(4) Enter < the new program number >.

(5) Press the soft key [O SET].



The No.9 O0001 is read and its file name is changed as O3002.

Path2. (1) Press the soft key [N READ].

(2) Enter < the program name to be input >.

(3) Press the soft key [F NAME].

If the file will be changed with a new file No., do the step nos. (4) and (5).

(4) Enter < the new program number >.

(5) Press the soft key [O SET].

READ/PUNCH (PROGRAM)		03333	N03333
NO.	FILE NAME	SIZE	DATE
0007	TEST. NC	70	02-11-29
0008	MACROVAR. DAT	332	02-11-27
0009	O0001	68	02-11-27
0010	PITCHERR. DAT	14342	02-11-27
[PROGRAM]			
06666	03333	01234	08652 05678 00010
02001	02002	02003	02004 02005 00052
00053	00054	00055	00056 00057 00058
02059	00060	07000	07001 07002 07003
READ FILE NAME=TEST. NC			
PROGRAM NO. = 5600			
S 0 T0000			
EDIT **** **			
10:03:58			
[F NAME]	[O SET]	[STOP]	[CAN] [EXEC]

The No. 7 TEST. NC
is read and its file name
is changed as O5600.



If the file is not edited a program No. Oxxxx and not specified a newprogram No., it will be named as O0001 automatically.

7. Press the soft key [EXEC] to execute.

8. Or press the soft key [CAN] to cancel this operation.

9. Or press the soft key [STOP] to stop this operation.

2.1.4 Outputting Programs

1. Under the EDIT mode, press the function key .
2. Press the rightmost soft key  (continuous menu key).
3. Press the soft key [ALL IO].
4. Press the soft key [PRGRM].
5. Press the soft key [(OPRT)].
6. Press the soft key [PUNCH].
7. Path1. Output a single program.

Enter < the program number >.

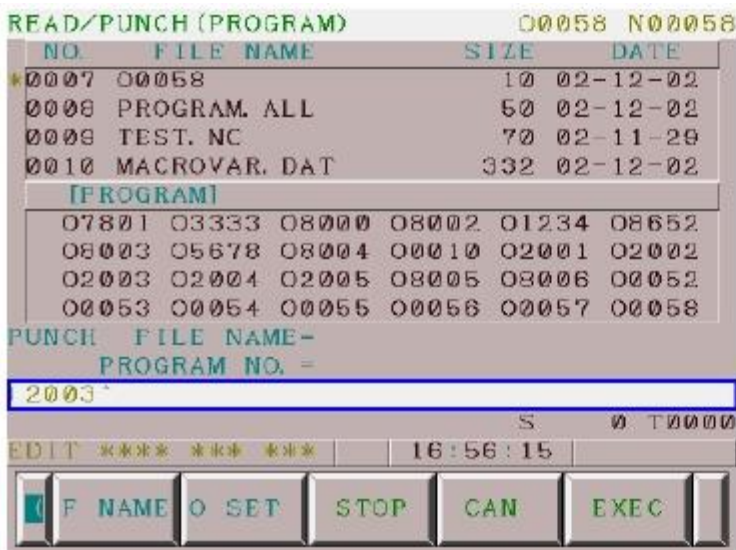

Output the program
O2003 in the NC
memory.

Path2. Output all programs stored.

Enter < -9999 >.

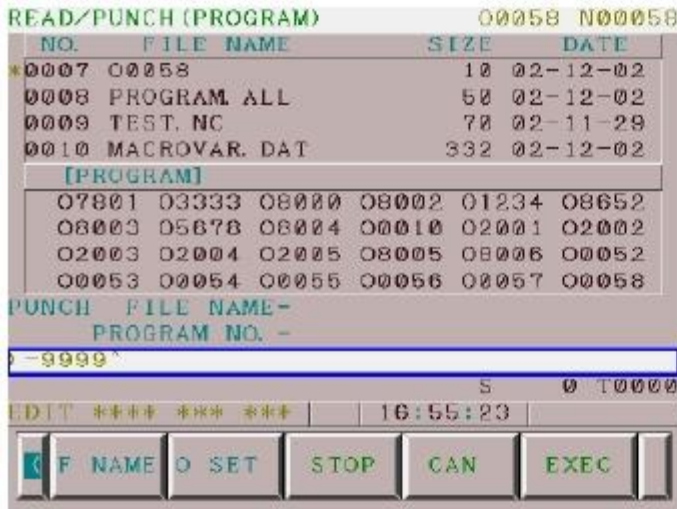

Output all programs in the NC memory.

Path3. Output multiple programs.

Enter < the first program number > and press the MDI keys **SHIFT** **[,]**.

then enter < the last program number >.



Output programs 02003 ~ 00058 in the NC memory.

8. Press soft key **[O SET]**.

If the file will be changed with a new file name, do the step nos. (9) and (10).

9. Enter < the program file name >.

If no file name is specified when writing all programs or multiple programs, the file name **PROGRAM.ALL** is used for registration.

10. Press the soft key **[F NAME]**.

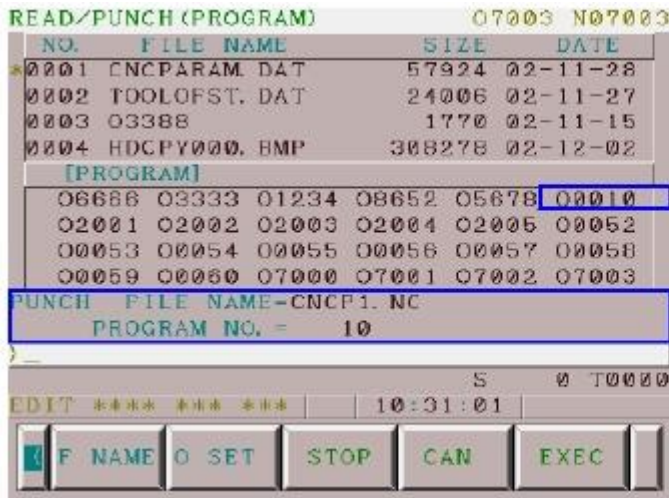



The program 00010 in the NC memory is output and changed name as CNCP1.NC.

11. Press the soft key [EXEC] to execute.
12. Or press the soft key [CAN] to cancel this operation.
13. Or press the soft key [STOP] to stop this operation.

Note : (1) When a file is with the same name already registered in the memory card, the existed file will be overwritten.
(2) File name is not longer than 8 characters, and extension not longer than 3 characters.

2.1.5 Deleting a File



1. Under the EDIT mode, press the function key .
2. Press the rightmost soft key  (continuous menu key).
3. Press the soft key [ALL IO].
4. Press the soft key [PRGRM].
5. Press the soft key [(OPRT)].
6. Press the soft key [DELETE].
7. Enter < the file number (No.) >.



8. Press the soft key [F SET] to execute.
9. Press the soft key [EXEC] to cancel.
10. Or press the soft key [CAN] to cancel this operation,

2.2 Parameter Input/Output

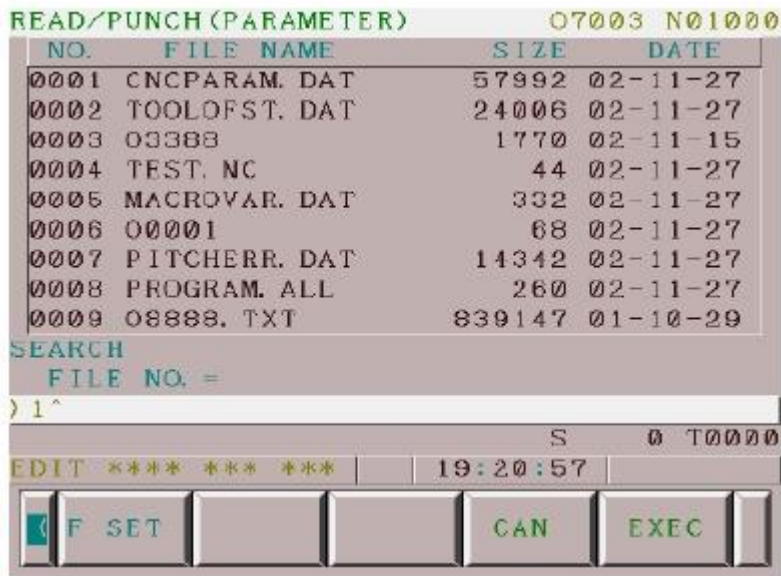

2.2.1 Searching for a Parameter

1. Under the EDIT mode, press the function key .
2. Press the rightmost soft key  (continuous menu key).
3. Press the soft key [ALL IO].
4. Press the soft key [PARAM].
5. Press the soft key [(OPRT)].
6. Press the soft key [F SRH].
7. Enter < the parameter file number (No.) >.



8. Press the soft key [F SET].
9. Press the soft key [EXEC] to execute.
10. Or press the soft key [CAN] to cancel this operation.

2.2.2 Inputting a Parameter

1. Under the EDIT mode, press the function key .
2. Press the rightmost soft key  (continuous menu key).
3. Press the soft key [ALL IO].
4. Press the soft key [PARAM].
5. Press the soft key [(OPRT)].
6. Path1. (1) Press the soft key [F READ].
(2) Enter < the parameter file number (No.) >.



(3) Press the soft key [F SET].

Path2. (1) Press the soft key [N READ].

(2) Enter < the parameter file name >.





(3) Press the soft key [F NAME].

7. Press the soft key [EXEC] to execute.

8. Or press the soft key [CAN] to cancel this operation.

9. Or press the soft key [STOP] to stop this operation.

2.2.3 Outputting Parameters

1. Under the EDIT mode, press the function key .
2. Press the rightmost soft key  (continuous menu key).
3. Press the soft key [ALL IO].
4. Press the soft key [PARAM].
5. Press the soft key [(OPRT)].
6. Press the soft key [PUNCH].
7. Enter < the parameter file name >.



IF the file name will not be input, jump to the step No.9 and the file is named as **CNCPARAM.DAT** automatically.



8. Press the soft key [F NAME].
9. Press the soft key [EXEC] to execute.
10. Or press the soft key [CAN] to cancel this operation.
11. Or press the soft key [STOP] to stop this operation.

Note : (1) When a file is with the same name already registered in the Memory Card, the existed file will be overwritten.
(2) File name is not longer than 8 characters, and extension not longer than 3 characters.

2.2.4 Deleting a File

1. Under the EDIT mode, press the function key .
2. Press the rightmost soft key  (continuous menu key).
3. Press the soft key [ALL IO].
4. Press the soft key [PARAM].
5. Press the soft key [(OPRT)].
6. Press the soft key [DELETE].
7. Enter < the parameter file number (No.) >.



8. Press the soft key [F SET].
9. Press the soft key [EXEC] to execute.
10. Or press the soft key [CAN] to cancel this operation

Chapter 6

Cutting Tool Condition List



The following tables are just for use of general cutting. If a tool or work piece with special material is used, please follow the data offered by the supplier.

1.1 FACE MILL

Face Mill								
Face Mill of Tungsten Carbide								
Steel								
	Rough milling				Finish milling			
D	S	V	F	fz	S	V	F	fz
mm	rpm	M / min	mm / min	mm / tooth	rpm	M / min	mm / min	mm / tooth
75	335	83	285	0.2	500	117	160	0.08
100	250	79	300	0.2	335	111	180	0.08
125	200	80	315	0.2	280	109	192	0.08
150	180	85	340	0.2	250	117	200	0.08

Cast iron								
	Rough milling				Finish milling			
D	S	V	F	fz	S	V	F	fz
mm	rpm	M / min	mm / min	mm / tooth	rpm	M / min	mm / min	mm / tooth
75	315	74	252	0.2	450	106	180	0.1
100	224	70	270	0.2	315	99	189	0.1
125	180	71	288	0.2	250	100	250	0.1
150	160	75	320	0.2	224	106	224	0.1

Aluminum								
	Rough milling				Finish milling			
D	S	V	F	fz	S	V	F	fz
mm	rpm	M / min	mm / min	mm / tooth	rpm	M / min	mm / min	mm / tooth
75	1400	330	1050	0.25	1800	424	540	0.1
100	1000	314	1000	0.25	1400	442	560	0.1
125	800	314	1000	0.25	1120	442	560	0.1
150	710	300	1065	0.25	900	424	540	0.1

1.2 END MILL

End Mill										
End Mill of H.S.S.										
Steel										
	Rough milling					Finish milling				
D	S	V	F	fz	t	S	V	F	fz	t
Mm	rpm	M/min	mm/min	mm/tooth	tooth	rpm	M/min	mm/min	mm/tooth	tooth
5	1400	23	84	0.03	2	1600	25	192	0.03	4
8	900	23	90	0.05	2	1000	25	160	0.04	4
10	710	22	85	0.06	2	800	25	128	0.04	4
15	450	21	63	0.07	2	560	26	112	0.05	4
20	335	22	50	0.07	2	400	25	96	0.06	4
30	224	21	31	0.07	2	280	26	67	0.06	4
40	180	23	25	0.07	2	200	25	48	0.06	4

Cast iron										
	Rough milling					Finish milling				
D	S	V	F	fz	t	S	V	F	fz	t
Mm	rpm	M/min	mm/min	mm/tooth	tooth	rpm	M/min	mm/min	mm/tooth	tooth
5	1600	25	192	0.06	2	1800	28	216	0.03	4
8	1000	25	140	0.07	2	1250	31	200	0.04	4
10	800	25	128	0.08	2	1000	31	200	0.05	4
15	560	26	112	0.1	2	630	30	126	0.05	4
20	400	25	80	0.1	2	500	31	120	0.06	4
30	280	26	56	0.1	2	315	30	76	0.06	4
40	200	25	44	0.11	2	250	31	60	0.06	4

Aluminum										
	Rough milling					Finish milling				
D	S	V	F	fz	t	S	V	F	fz	t
Mm	rpm	M/min	mm/min	mm/tooth	tooth	rpm	M/min	mm/min	mm/tooth	tooth
5	3150	49	315	0.05	2	3150	49	189	0.03	2
8	2240	56	268	0.06	2	2800	70	168	0.03	2
10	1800	56	252	0.07	2	2240	70	134	0.03	2
15	1250	59	225	0.09	2	1600	75	128	0.04	2
20	1000	63	200	0.1	2	1250	79	125	0.05	2
30	630	59	126	0.1	2	800	75	80	0.05	2
40	500	63	100	0.1	2	630	79	63	0.05	2

1.3 BORING BAR

Boring Bar								
Boring Bar of Tungsten Carbide								
Cast iron								
D	Rough boring				Finish boring			
	S	V	F	fz	S	V	F	fz
mm	rpm	M/min	mm/min	mm/tooth	rpm	M/min	mm/min	mm/tooth
15	1600	75	160	0.1	2000	95	120	0.06
20	1120	70	112	0.1	1600	100	96	0.06
30	800	75	95	0.13	1000	95	70	0.07
40	560	70	73	0.13	800	100	56	0.07
50	450	71	59	0.13	630	99	44	0.07
60	400	75	56	0.16	500	95	40	0.08
80	280	70	45	0.16	400	100	32	0.08
100	224	71	36	0.16	315	99	25	0.08
120	200	75	40	0.2	250	95	25	0.1
150	160	75	32	0.2	200	94	20	0.1
200	112	71	22	0.2	160	100	16	0.1

Aluminum								
D	Rough boring				Finish boring			
	S	V	F	fz	S	V	F	fz
Mm	rpm	M/min	mm/min	mm/tooth	rpm	M/min	mm/min	mm/tooth
15	3150	148	315	0.1	3150	148	189	0.06
20	2240	152	224	0.1	2800	176	168	0.06
30	1600	150	192	0.12	1800	170	108	0.06
40	1120	141	134	0.12	1400	176	84	0.06
50	900	141	125	0.14	1120	176	67	0.06
60	800	150	112	0.14	900	170	63	0.07
80	560	141	90	0.16	710	178	50	0.07
100	450	141	72	0.16	560	176	39	0.07
120	400	150	72	0.18	450	170	36	0.08
150	315	148	58	0.18	400	188	32	0.08
200	224	141	36	0.18	280	176	22	0.08

1.4 DRILL

Drill								
Drill of H.S.S.								
D	Steel				Cast iron			
	S	V	F	fr	S	V	F	fr
mm	rpm	M/min	mm/min	mm/rev	rpm	M/min	mm/min	mm/rev
2	3150	20	126	0.02	3150	20	189	0.03
3	2500	24	125	0.025	2500	24	200	0.04
4	2000	25	120	0.03	2000	25	200	0.05
5	1600	25	128	0.04	1600	25	192	0.06
6	1250	24	125	0.05	1400	24	224	0.08
8	1000	25	120	0.06	1000	25	200	0.1
10	800	25	128	0.08	800	25	192	0.12
12	630	24	113	0.09	630	24	151	0.12
14	560	25	112	0.1	560	25	146	0.13
16	500	25	110	0.11	500	25	150	0.15
18	450	25	108	0.12	450	25	153	0.17
20	400	25	100	0.125	400	25	160	0.2
25	315	25	95	0.15	315	25	126	0.2
30	280	26	84	0.15	280	26	112	0.2
35	224	25	67	0.15	224	25	90	0.2
40	200	25	60	0.15	200	25	80	0.2
45	180	25	54	0.15	180	25	72	0.2
50	160	25	48	0.15	160	25	64	0.2

Aluminum									
D	S	V	F	fr	D	S	V	F	fr
Mm	rpm	M/min	mm/min	mm/rev	mm	rpm	M/min	mm/min	mm/rev
2	3150	20	189	0.03	16	1600	80	384	0.12
3	3150	30	252	0.04	18	1400	79	392	0.14
4	3150	40	315	0.05	20	1250	79	400	0.16
5	3150	52	315	0.05	25	1000	79	400	0.2
6	3150	59	378	0.06	30	800	75	320	0.2
8	2800	70	448	0.08	35	710	78	284	0.2
10	2500	79	500	0.1	40	630	79	252	0.2
12	2000	75	400	0.1	45	56	80	224	0.2
14	1800	79	396	0.11	50	500	79	200	0.2

1.5 REAMER

Reamer
Reamer of H.S.S.

D	Steel				Cast iron			
	S	V	F	fr	S	V	F	fr
mm	rpm	M / min	mm / min	mm / rev	rpm	M / min	mm / min	mm / rev
5	250	4	0.3	0.3	355	5.6	178	0.5
10	125	4	0.3	0.3	180	5.7	108	0.6
15	80	3.8	0.3	0.3	125	5.9	100	0.8
20	63	4	0.3	0.3	90	5.7	90	1
25	50	4	0.4	0.4	71	5.6	71	1
30	40	3.8	0.4	0.4	63	5.9	70	1.1
35	36	3.9	0.5	0.5	56	6.2	67	1.2
40	32	4	0.5	0.5	45	5.7	59	1.3
45	28	4	0.5	0.5	41	5.7	56	1.4
50	28	4.4	0.5	0.5	36	5.8	53	1.5

Aluminum

D	S	V	F	fr	D	S	V	F	fr
mm	rpm	M / min	mm / min	mm / rev	mm	rpm	M / min	mm / min	mm / rev
5	800	12.6	400	0.5	30	140	13.2	154	1.1
10	400	12.6	240	0.6	35	125	13.7	150	1.2
15	280	13.2	224	0.8	40	100	12.6	130	1.3
20	200	12.6	200	1	45	90	12.7	126	1.4
25	160	12.6	160	1	50	80	12.6	120	1.5

1.6 TAP

Tap						
Tap of H.S.S. for Metric Coarse Thread						
Metric D × Pitch	Steel			Cast iron / Aluminum		
	S	V	F	S	V	F
mm	rpm	M / min	mm / min	rpm	M / min	mm / min
M3 × 0.5	500	4.7	250	710	6.9	355
M4 × 0.7	400	5	280	560	7	392
M5 × 0.8	315	4.9	252	450	7	360
M6 × 1	250	4.7	250	355	6.9	355
M8 × 1.25	200	5	250	280	7	350
M10 × 1.5	160	4.9	240	224	7	336
M12 × 1.75	125	4.7	218	180	7	315
M14 × 2	112	4.9	224	160	7	320
M16 × 2	100	5	200	140	7	280
M18 × 2.5	90	5	225	125	7	312
M20 × 2.5	80	4.9	200	112	7.6	280
M22 × 2.5	71	4.9	177	100	6.9	250
M24 × 3	63	4.7	189	90	6.8	270
M27 × 3	56	4.7	168	80	6.8	240
M30 × 3.5	50	4.7	175	71	6.9	248
M33 × 3.5	50	5.2	175	71	7.4	248

Tap of H.S.S. for Tapered Pipe Thread						
Inched D × No. of Thread per 25.4 mm	Steel			Cast iron / Aluminum		
	S	V	F	S	V	F
	rpm	M / min	mm / min	rpm	M / min	mm / min
1 / 8 × 28	160	4.9	145	224	7	203
1 / 4 × 19	125	5.2	167	180	7.4	240
3 / 8 × 19	100	5.3	133	140	7.3	186
1 / 2 × 14	80	5.2	145	112	7.4	211
3 / 4 × 14	63	5.2	114	90	7.5	163
1 × 11	50	5.2	115	71	7.4	163
1-1 / 4 × 11	40	5.3	92	56	7.4	128
1-1 / 2 × 11	36	5.3	81	50	7.5	115
2 × 11	28	5.2	64	40	7.5	92

Chapter 7

Part Manual

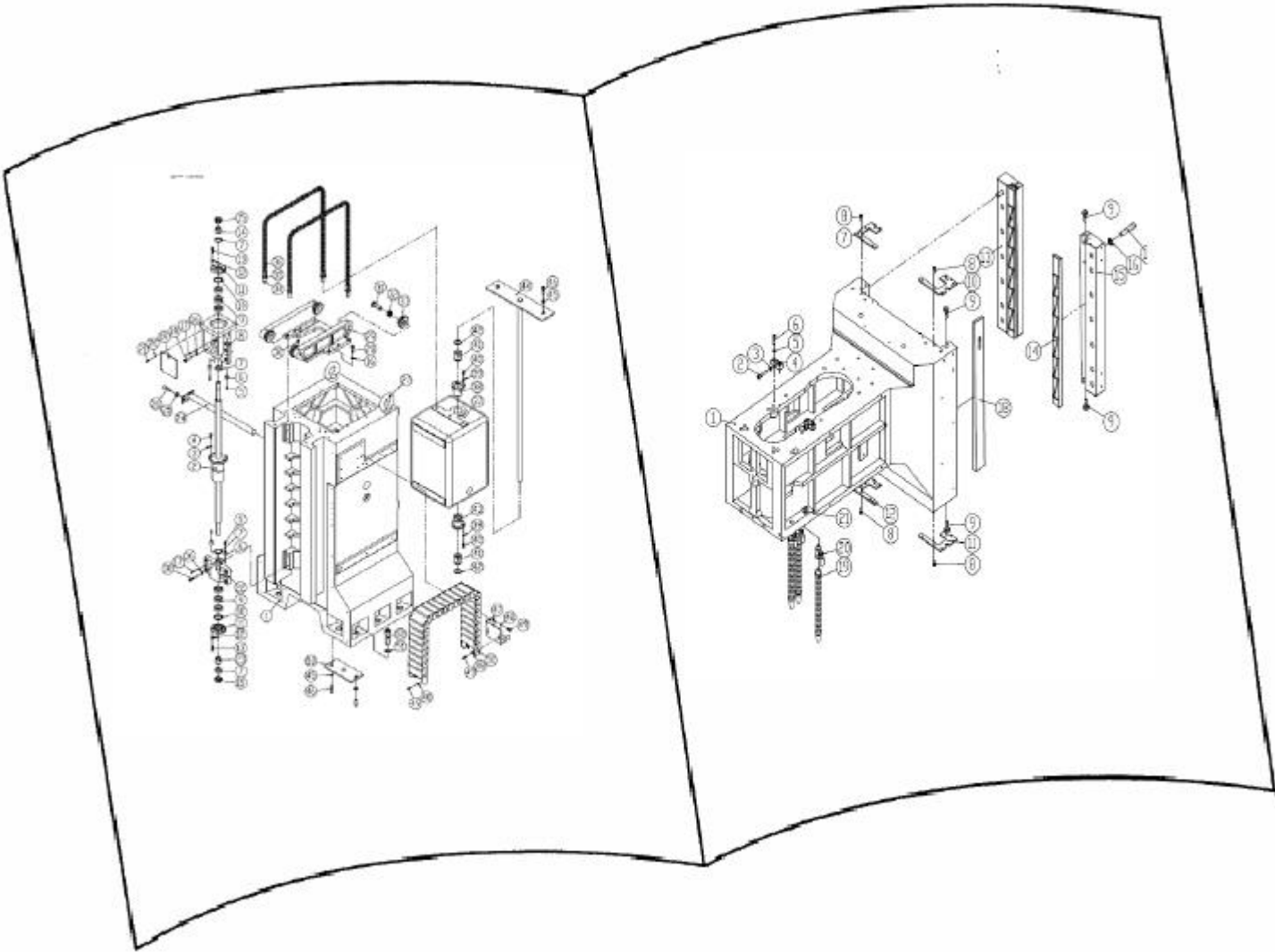

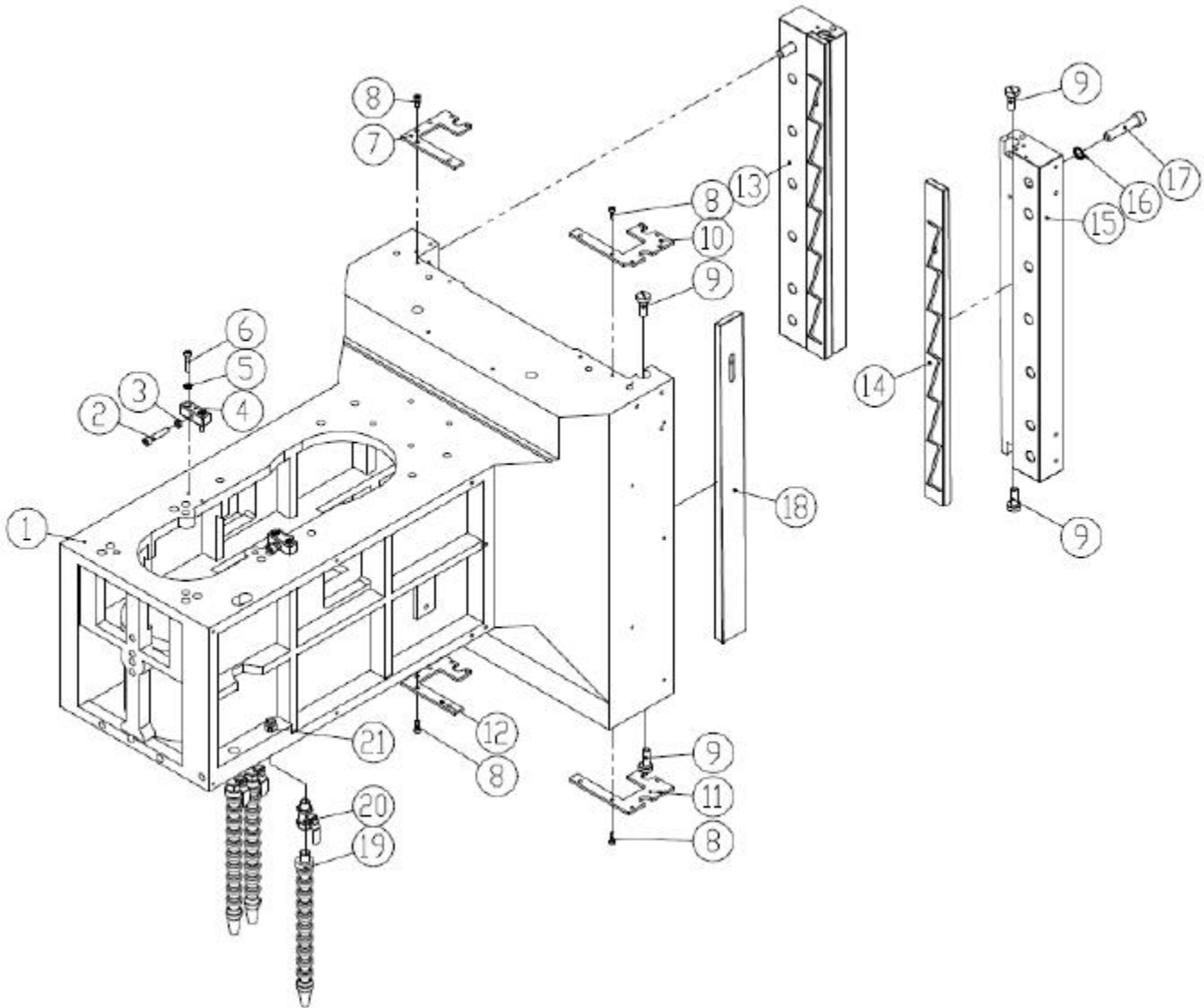
1. SPINDLE HEAD**1) SV4328 / SV5128**

Item	ENG-NAME	Qty
1	Main bracket	1
2	M8*40mm screw	2
3	Hexagonal nut	2
4	Adjusting spacer for belt	2
5	M6 safety washer	4
6	M6*30mm screw	4
7	Z axis left upper wipe	1
8	M5*15mm screw	24
9	Adjusting embedded bolt	6
10	Z axis right upper wiper	1
11	Z axis right under wiper	1
12	Z axis left under wiper	1
13	Left side guide plate	1
14	Embedded guide plate	2
15	Right side guide plate	1
16	M14 safety washer	14
17	M14*60mm screw	14
18	Embedded plate	1
19	Plastic oil hose (3/8*10p*6mm)	3
20	Ball valve	3
21	Straight connector (5.8mm*3.8PT)	1

2) SV6332

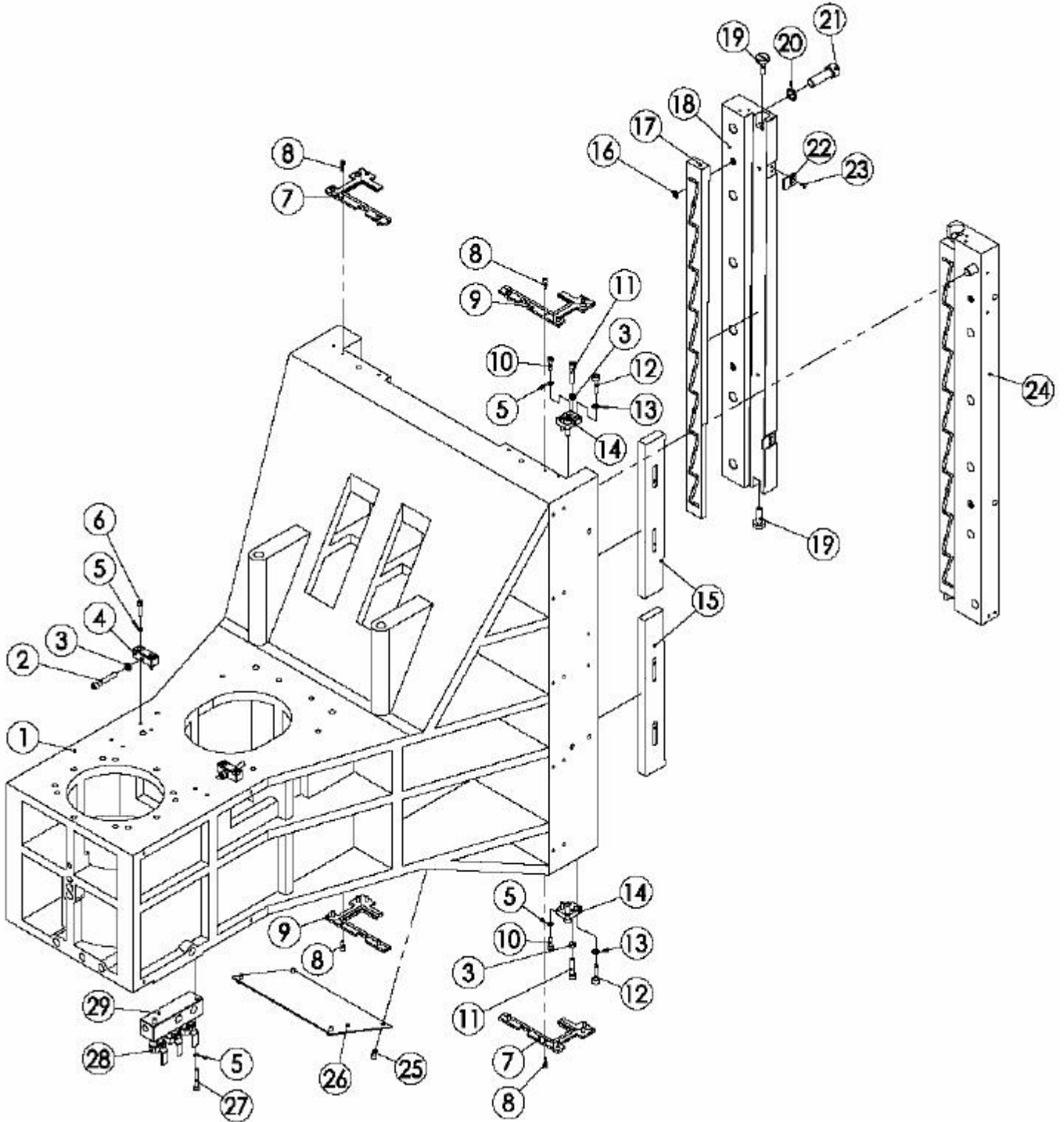

Item	ENG-NAME	Qty
1	Main bracket	1
2	M8*50mm screw	2
3	Hexagon socket head nut	4
4	Adjusting spacer for belt	2
5	M6 safety washer	10
6	Hexagon socket head screw	4
7	Z axis left upper wipe	2
8	M5*15mm screw	20
9	Z axis right upper wiper	2
10	M6*20mm screw	7
11	M8*35mm screw	2
12	M8*30mm screw	4
13	M8 safety washer	4
14	Adjustable spacer	2
15	Head embedded plate	2
16	O-ring	4
17	Head embedded guide plate	2
18	Left side guide plate	1
19	Adjusting embedded bolt	9
20	M16 safety washer	12
21	M16*50mm screw	12
22	Embedded plate cover	4
23	Hexagon socket countersunk head screw	8
24	Right side guide plate	1
25	M6*10mm screw	4
26	Under cover of head	1
27	M6*40mm screw	2
28	Ball valve	3
29	Lube oil distributor	1

2. Column

1) SV42328 / SV5128

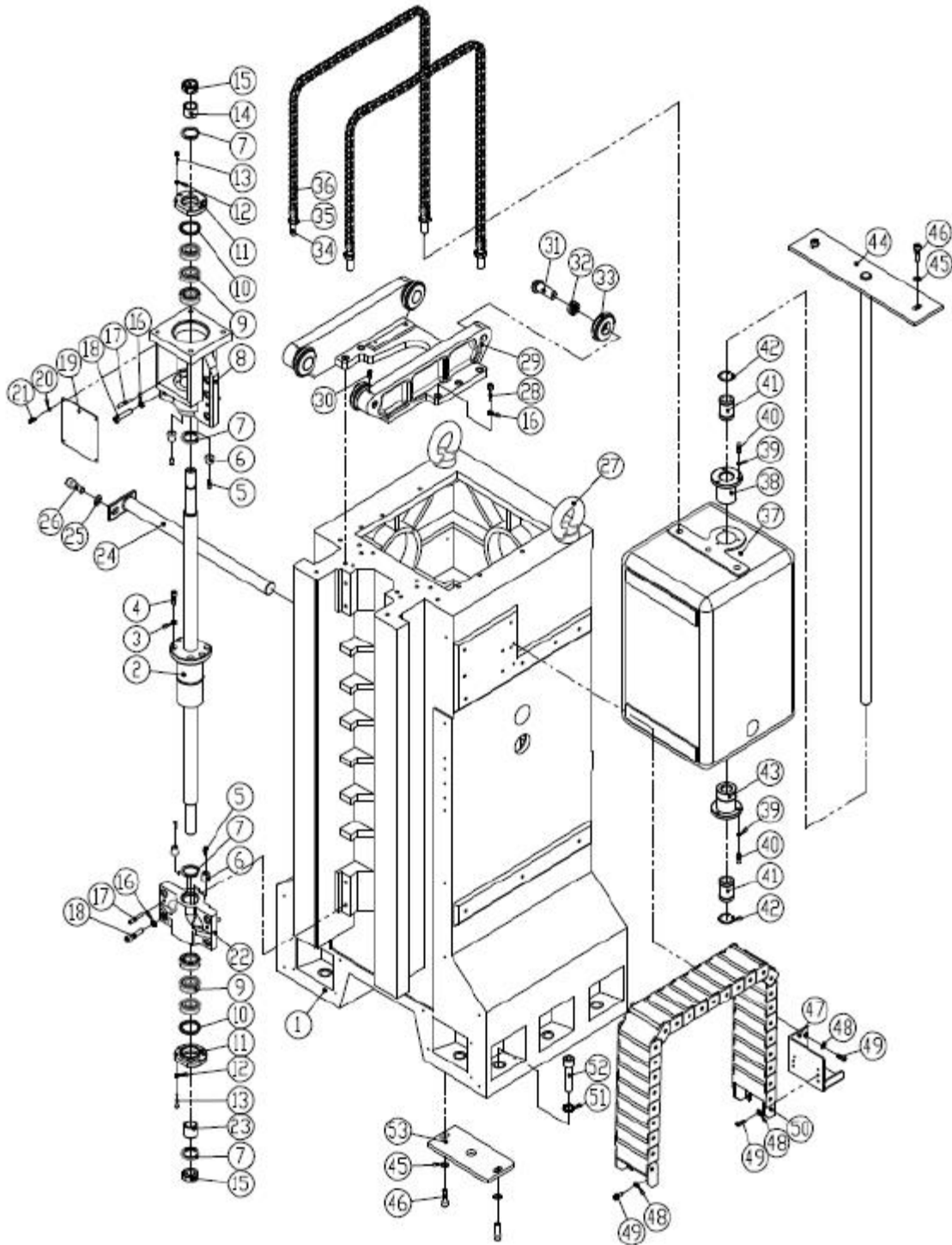

Item	ENG-NAME	Qty	Item	ENG-NAME	Qty
1	Column	1	28	M12*45mm screw	10
2	Ball screw	1	29	Weight balance support frame	1
3	M10 safety washer	6	30	M10*20mm screw	4
4	M10*30mm screw	6	31	Sprocket shaft	4
5	M5*20mm screw	4	32	Needle bearing	4
6	Z axis left stopper	4	33	Sprocket wheel	4
7	Oil seal	4	34	Socket bolt	4
8	Z axes motor adapter	1	35	Nut	4
9	Bearing	6	36	Sprocket	2
10	Outside bearing retainer	2	37	Weight balance case	1
11	Bearing cap	2	38	Weight balance upper bearing socket	1
12	M8 safety washer	12	39	M6 Safety washer	6
13	M8*35mm screw	12	40	M6*25mm screw	6
14	Inside bearing retainer	1	41	Linear bearing	2
15	Lock nut	2	42	Restrain ring	2
16	M12 safety washer	18	43	Weight balance under bearing socket	1
17	Tapping pin with internal thread (1~48")	4	44	Weight balance guide	1
18	M12*55mm screw	8	45	M12 washer	4
19	Z axes motor adapter cover	1	46	M12*40mm screw	4
20	M5 washer	4	47	Z direction cable chain bracket	1
21	M5*15mm screw	4	48	M8 washer	12
22	Z axis bearing case	1	49	M8*20mm screw	12
23	Inside bearing retainer	1	50	Z direction cable chain	1
24	Weight balance bracket	1	51	M24 safety washer	10
25	M16 washer	1	52	M24*90mm screw	10
26	M16*45mm screw	1	53	Weight balance guide plate	1
27	M36 hanging ring	2			

1) SV6332

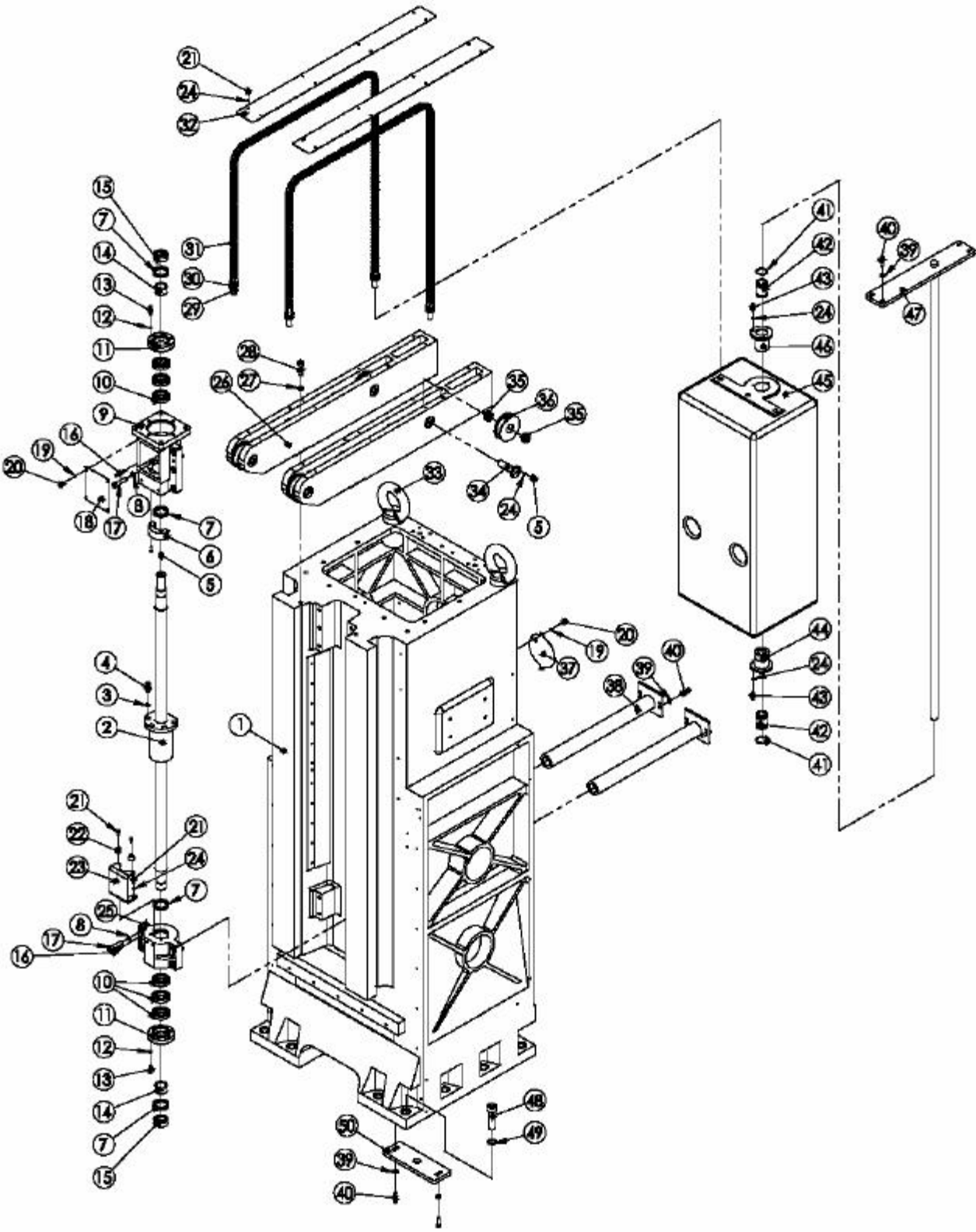

Item	ENG-NAME	Qty	Item	ENG-NAME	Qty
1	Column	1	26	Weight balance bracket	2
2	Ball screw	1	27	M16 safety washer	8
3	M12 safety washer	5	28	M16*50mm screw	8
4	M12*30mm screw	5	29	Sprocket bolt	4
5	M6*20mm screw	14	30	Nut	4
6	stopper	1	31	Sprocket	2
7	Oil seal	4	32	Weight balance support frame	2
8	M14 safety washer	10	33	Sprocket wheel M36 hanging ring	2
9	Z axes motor adapter	1	34	Sprocket shaft	4
10	Bearing	6	35	Needle bearing	8
11	Bearing cap	2	36	Sprocket wheel	4
12	M8 safety washer	12	37	Hole cover of column back	2
13	M8*30mm screw	12	38	Weight balance bracket	2
14	Inside bearing retainer	2	39	M10 washer	10
15	Lock nut	2	40	M10*35mm screw	10
16	Tapping pin with internal thread(1~48")	4	41	Restrain ring	2
17	M14*60mm screw	10	42	Linear bearing	2
18	motor adapter cover	1	43	Hexagon socket head screw	6
19	M5 washer	8	44	Weight balance under bearing socket	1
20	M5*15mm screw	8	45	Weight balance case	1
21	M6*15mm screw	20	46	Weight balance upper bearing socket	1
22	stopper	2	47	Weight balance guide	1
23	Stopper base	1	48	M24*90mm screw	12
24	M6 safety washer	36	49	M24safety washer	12
25	Z axis bearing case	1	50	Under weight balance bracket	1

3. Base

1) SV42328 / SV5128

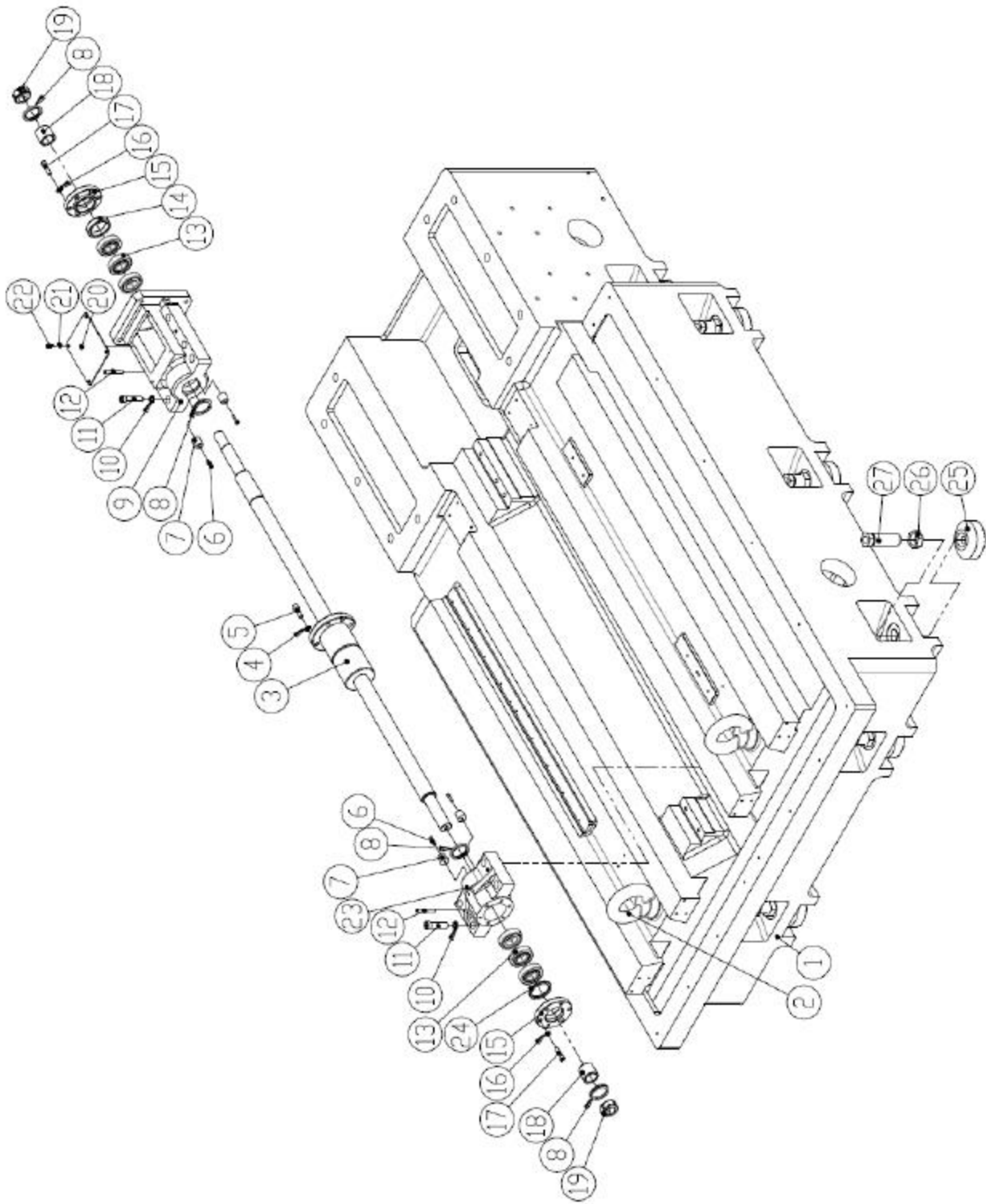

Item	ENG-NAME	Qty
1	Base	1
2	M36 hanging ring	2
3	Ball screw	1
4	M10 safety washer	6
5	M10*30mm screw	6
6	M5*20mm screw	4
7	Y axis left stopper	4
8	Oil seal	4
9	Y axes motor adapter	1
10	M12 safety washer	10
11	M12*50mm screw	10
12	Tapping pin with internal thread(1~48")	4
13	Bearing	6
14	Outside bearing retainer	1
15	Bearing cap	2
16	M8 safety washer	12
17	M8*35mm screw	12
18	Inside bearing retainer	2
19	Lock nut	2
20	Y axes motor adapter cover	1
21	M5 washer	4
22	M5*15mm screw	4
23	Axis bearing case	1
24	Outside bearing retainer	1
25	Adjustable level base	12
26	Adjustable level nut	12
27	Adjustable level bolt	12

2) SV6332

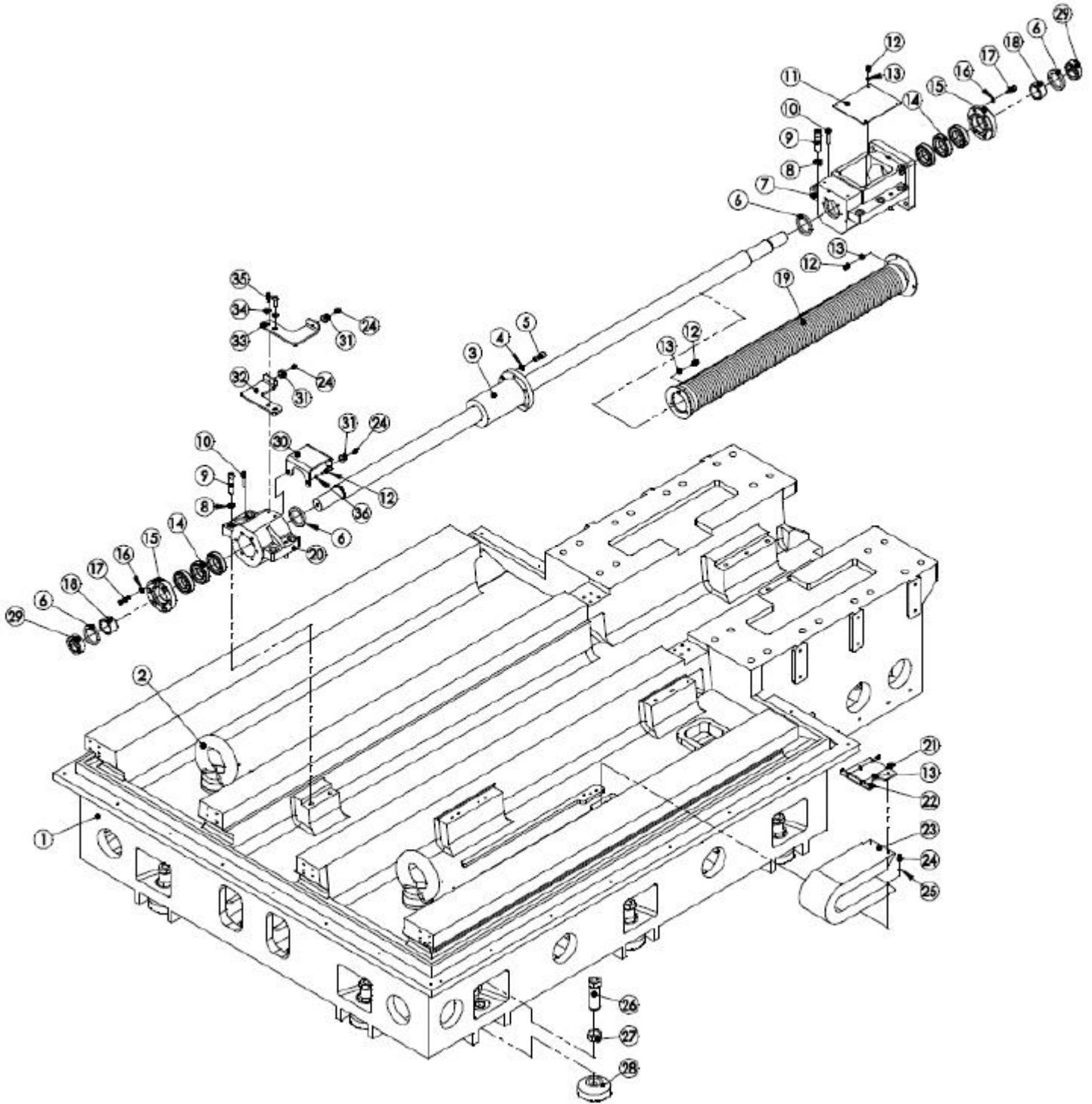

Item	ENG-NAME	Qty	Item	ENG-NAME	Qty
1	Base	1	19	Ball screw round bellow cover	1
2	M36 hanging ring	2	20	Axis bearing case	1
3	Ball screw	1	21	M6*20mm screw	2
4	M12 safety washer	5	22	Cable chain bracket	1
5	M12*30mm screw	5	23	Cable chain	1
6	Oil seal	4	24	M5*15mm screw	8
7	Y axes motor adapter	1	25	M5 washer	4
8	M14 safety washer	10	26	Adjustable level bolt	12
9	M14*60mm screw	10	27	Adjustable level nut	12
10	Tapping pin with internal thread (1~48")	4	28	Adjustable level base	12
11	Y axes motor adapter cover	1	29	Lock nut	2
12	M6*15mm screw	12	30	Stopper base	1
13	M6 washer	12	31	Stopper	4
14	Bearing	6	32	Y axis stopper bracket (left)	1
15	Bearing cap	2	33	Y axis stopper bracket (right)	1
16	M8 safety washer	12	34	M8 washer	2
17	M8*30mm screw	12	35	M8*25mm screw	2
18	Inside bearing retainer	2	36	M6 safety washer	2
19	Ball screw round bellow cover	1			

4. Saddle & Table

1) SV42328 / SV5128

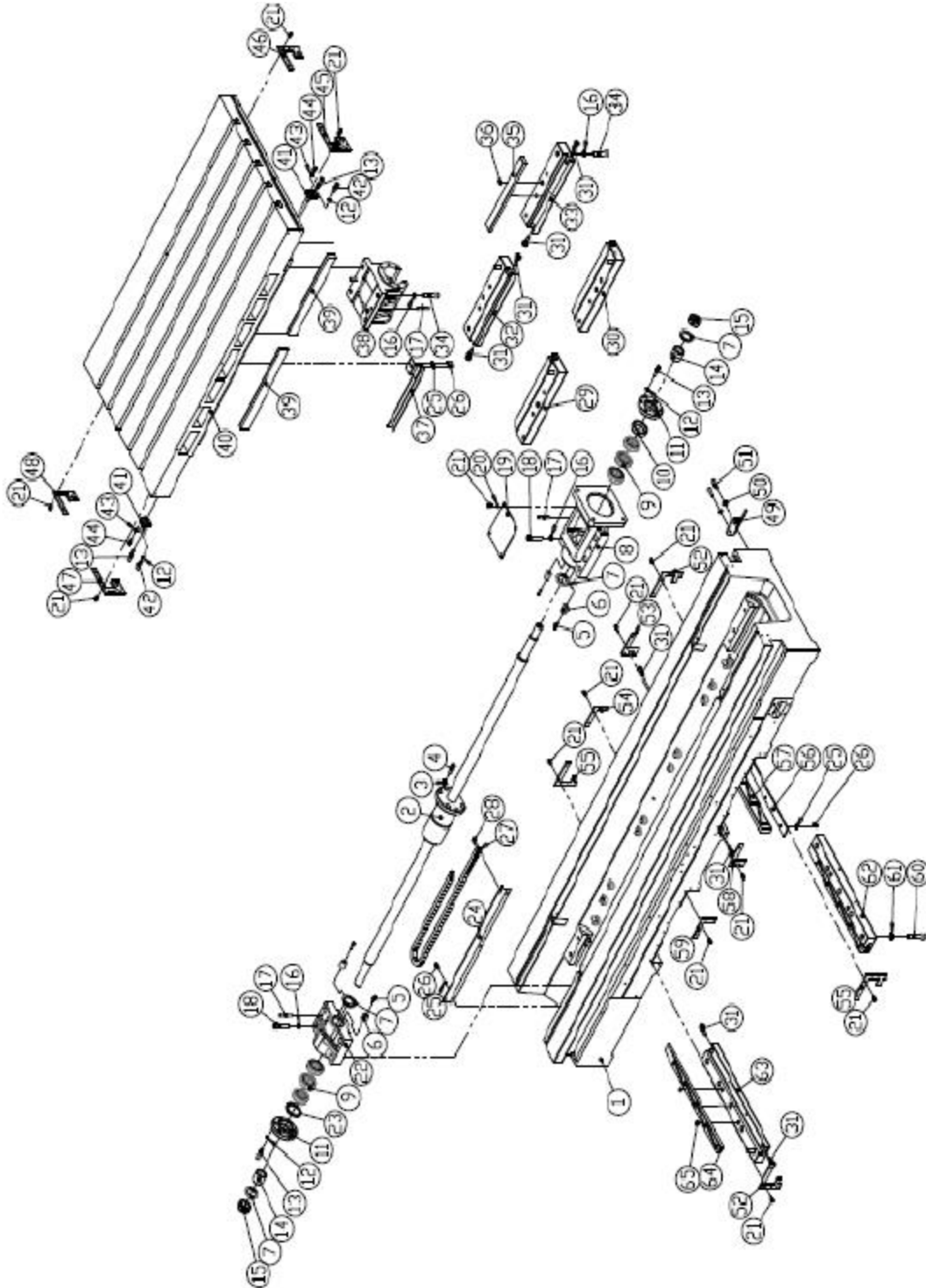

Item	ENG-NAME	Qty	Item	ENG-NAME	Qty
1	Saddle base	1	34	M12*55mm screw	20
2	Ball screw	1	35	X axis embedded guide plate	4
3	M10 safety washer	6	36	O-ring	4
4	M10*30mm screw	6	37	X direction cable chain bracket	1
5	M5*20mm screw	4	38	X axis nut base	1
6	X axis left stopper	4	39	Table embedded plate	2
7	Oil seal	4	40	Table	1
8	X & Y axes motor adapter	1	41	Adjustable spacer	2
9	Bearing	6	42	M8*30mm screw	4
10	Outside bearing retainer	1	43	M6 safety washer	4
11	Bearing cap	2	44	M6*20mm screw	4
12	M8 safety washer	16	45	X axis right front wiper	1
13	M8*35mm screw	14	46	X axis right rear wiper	1
14	Inside bearing retainer	2	47	X axis left front wiper	1
15	Lock nut	2	48	X axis left rear wiper	1
16	M12 safety washer	27	49	Y direction cable chain	1
17	Tapping pin with internal thread (1~48")	6	50	M8 washer	2
18	M12*50mm screw	10	51	M8*25mm screw	2
19	X & Y axes motor adapter cover	1	52	Y axis left outside wiper	2
20	M5 washer	4	53	Y axis right rear wiper	1
21	M5*15mm screw	68	54	Y axis left rear wiper	1
22	Axis bearing case	1	55	Y axis right outside wiper	2
23	Outside bearing retainer	1	56	Y axis support embedded plate	1
24	X direction cable chain bracket	1	57	Embedded saddle plate	1
25	M6 washer	9	58	Y axis right front wiper	1
26	M6*15mm screw	9	59	Y axis left front wiper	1
27	Cable chain	1	60	M14*60mm screw	10
28	M4*8mm screw	4	61	M14 safety washer	10
29	X axis left front pressure plate	1	62	Right saddle pressure plate	1
30	X axis right front pressure plate	1	63	Left saddle pressure plate	1
31	Adjustable embedded bolt	14	64	Embedded saddle guide plate	2
32	X axis left rear pressure plate	1	65	O-ring	4
33	X axis right rear pressure plate	1			20

2) SV6332

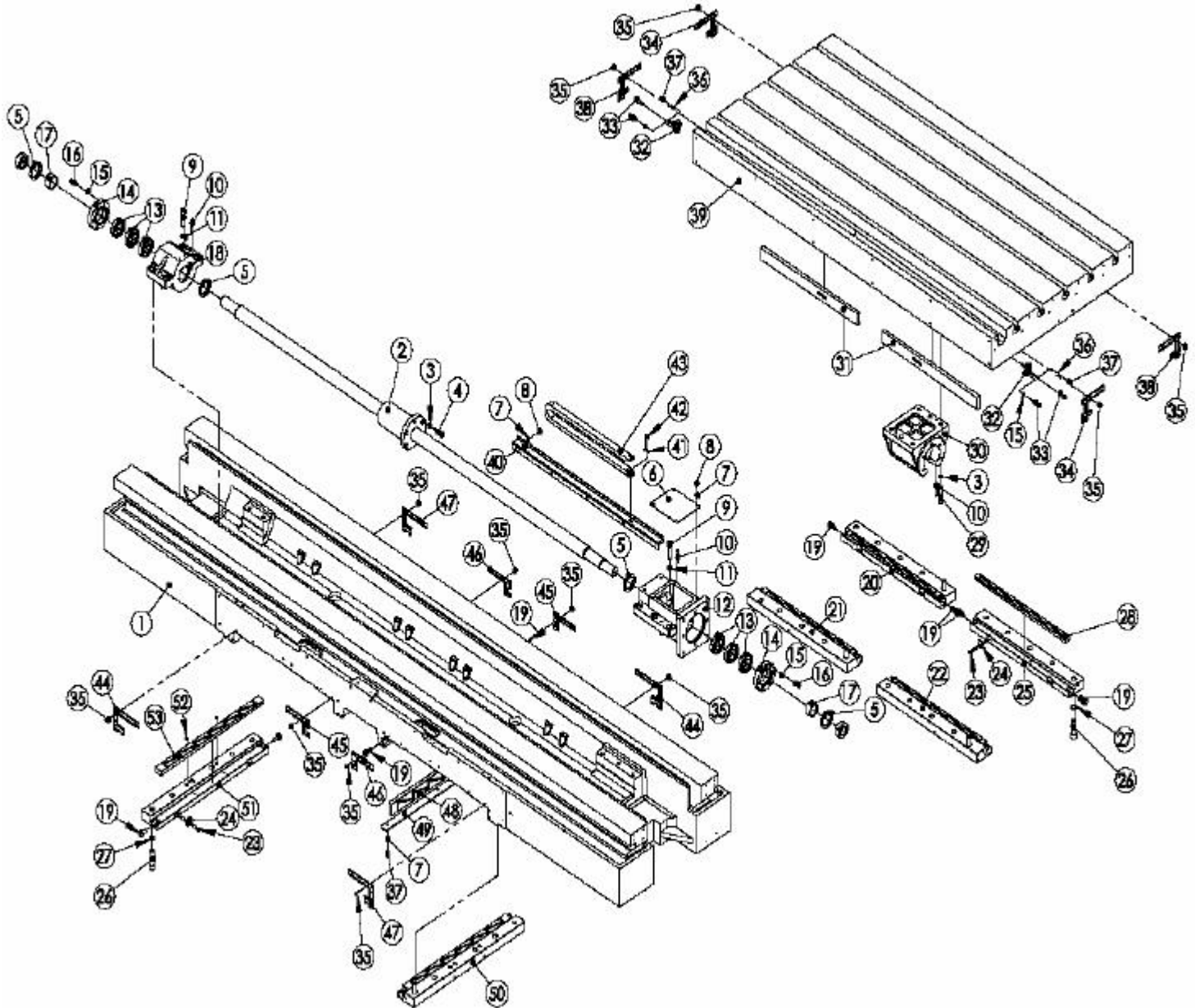

Item	ENG-NAME	Qty	Item	ENG-NAME	Qty
1	Saddle base	1	28	X axis embedded guide plate	4
2	Ball screw	1	29	M12*50mm screw	6
3	M12 safety washer	11	30	X axis nut base	1
4	M12*30mm screw	5	31	Table embedded plate	2
5	Oil seal	4	32	Adjustable spacer	2
6	X axis left stopper	1	33	M8*35mm screw	6
7	Oil seal	11	34	X axis left front wiper	2
8	M6*15mm screw	8	35	M5*15mm screw	60
9	M14*60mm screw	10	36	M6 safety washer	4
10	Tapping pin with internal thread (1~48")	6	37	M6*20mm screw	7
11	M14 safety washer	10	38	X axis right front wiper	2
12	X axes motor adapter	1	39	Table	1
13	Bearing	6	40	X direction cable chain bracket	1
14	Bearing cap	2	41	M4 safety washer	4
15	M8 safety washer	16	42	M4*10mm screw	4
16	M8*30mm screw	12	43	cable chain	1
17	Inside bearing retainer	2	44	Y axis left outside wiper	2
18	X axes bearing case	1	45	Y axis left inside wiper	2
19	Adjustable embedded bolt	14	46	Y axis right inside wiper	2
20	X axis left rear pressure plate	1	47	Y axis right outside wiper	2
21	X axis left front pressure plate	1	48	Embedded saddle plate	1
22	X axis right front pressure plate	1	49	Y axis support embedded plate	1
23	Hexagon socket countersunk head screw	24	50	Right saddle pressure plate	1
24	X direction cable chain bracket	12	51	Left saddle pressure plate	1
25	X axis right rear pressure plate	1	52	O-ring	4
26	M16*60mm screw	32	53	Embedded saddle guide plate	2
27	M16 safety washer	32	54	Lock nut	2

5. Lubrication

5.1 Saddle Distributor

1) SV4328 / SV5128

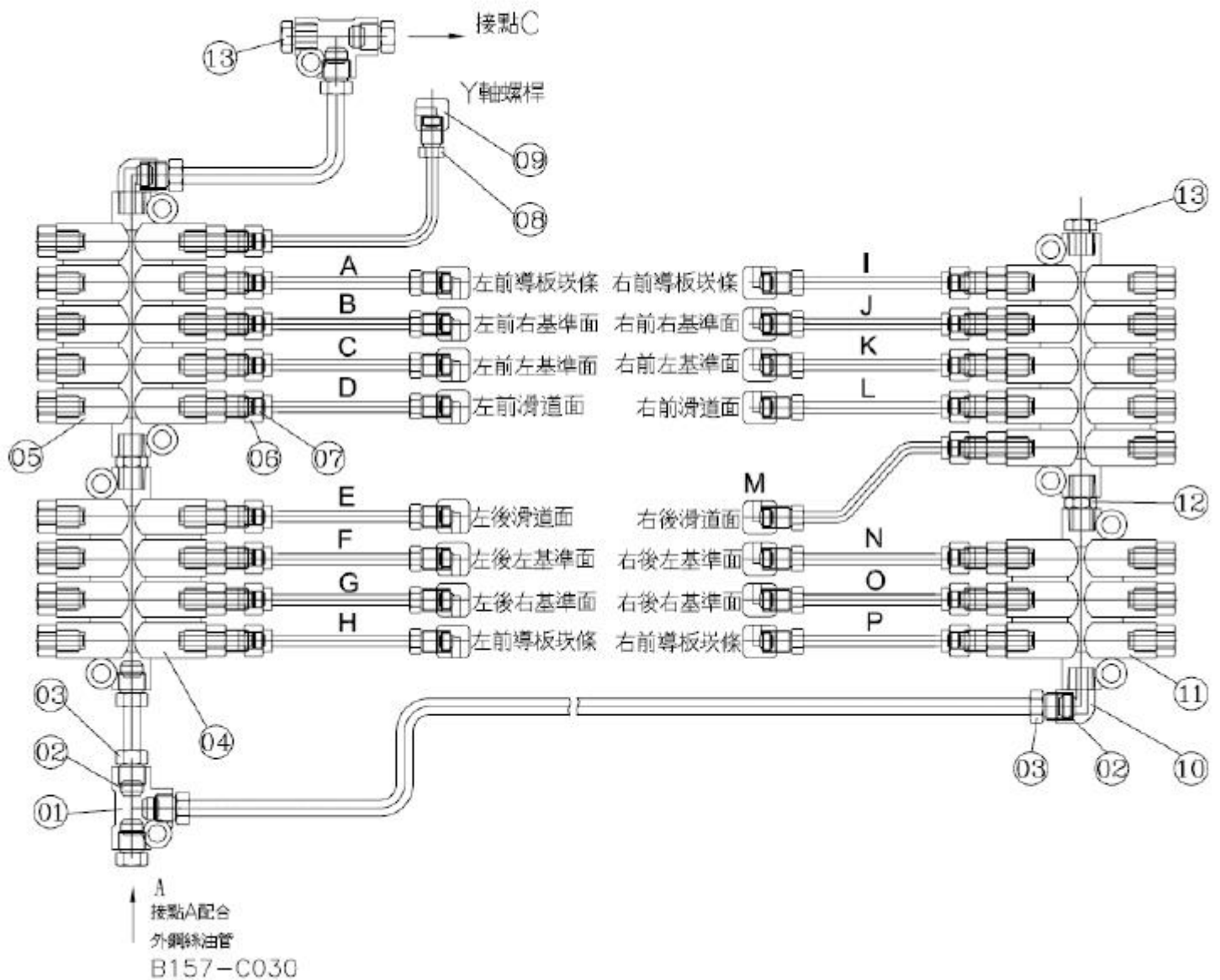

Item	Size	Eng- Name	Qty
1.	PKD6	Tee	2
2.	PB6	Nipple	8
3.	PA6	Bushing	8
4.	HBL-4	Quantitative Distributor	1
5.	HBL-5	Quantitative Distributor	2
6.	PAN4	Nut	17
7.	PB4	Nipple	34
8.	PA4	Bushing	17
9.	PH4-1	Street Elbow	17
10.	PH601	Street Elbow	2
11.	HBL-3	Quantitative Distributor	1
12.	PQ101	Coupling	2
13.	PG01	Plug	1

2) SV6332

Connect A with oil tube (B085-T060)

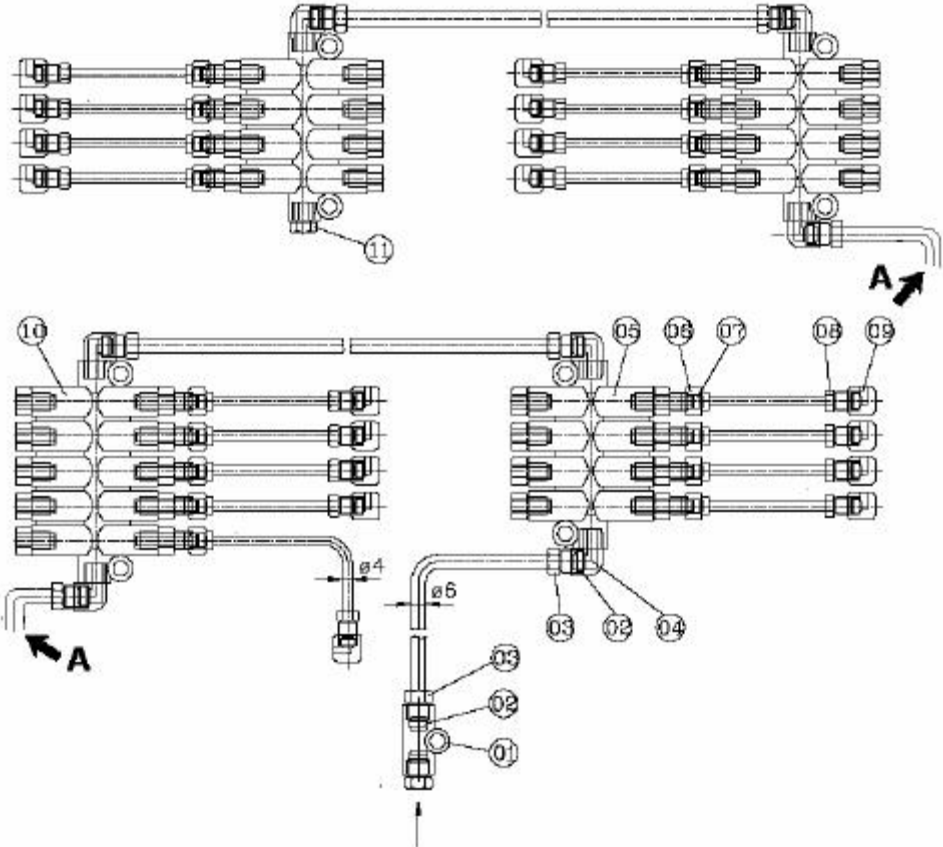

Item	Size	Eng- Name	Qty
1.	JD6	Coupling	1
2.	PB6	Nipple	9
3.	PA6	Bushing	9
4.	PH601	Street Elbow	7
5.	HBL-4	Quantitative Distributor	3
6.	PAN4	Nut	17
7.	PB4	Nipple	34
8.	PA4	Bushing	17
9.	PH4-1	Street Elbow	17
10.	HBL-5	Quantitative Distributor	2
11.	PG01	Plug	1

5.2 Table Distributor

1) SV4328 / SV5128

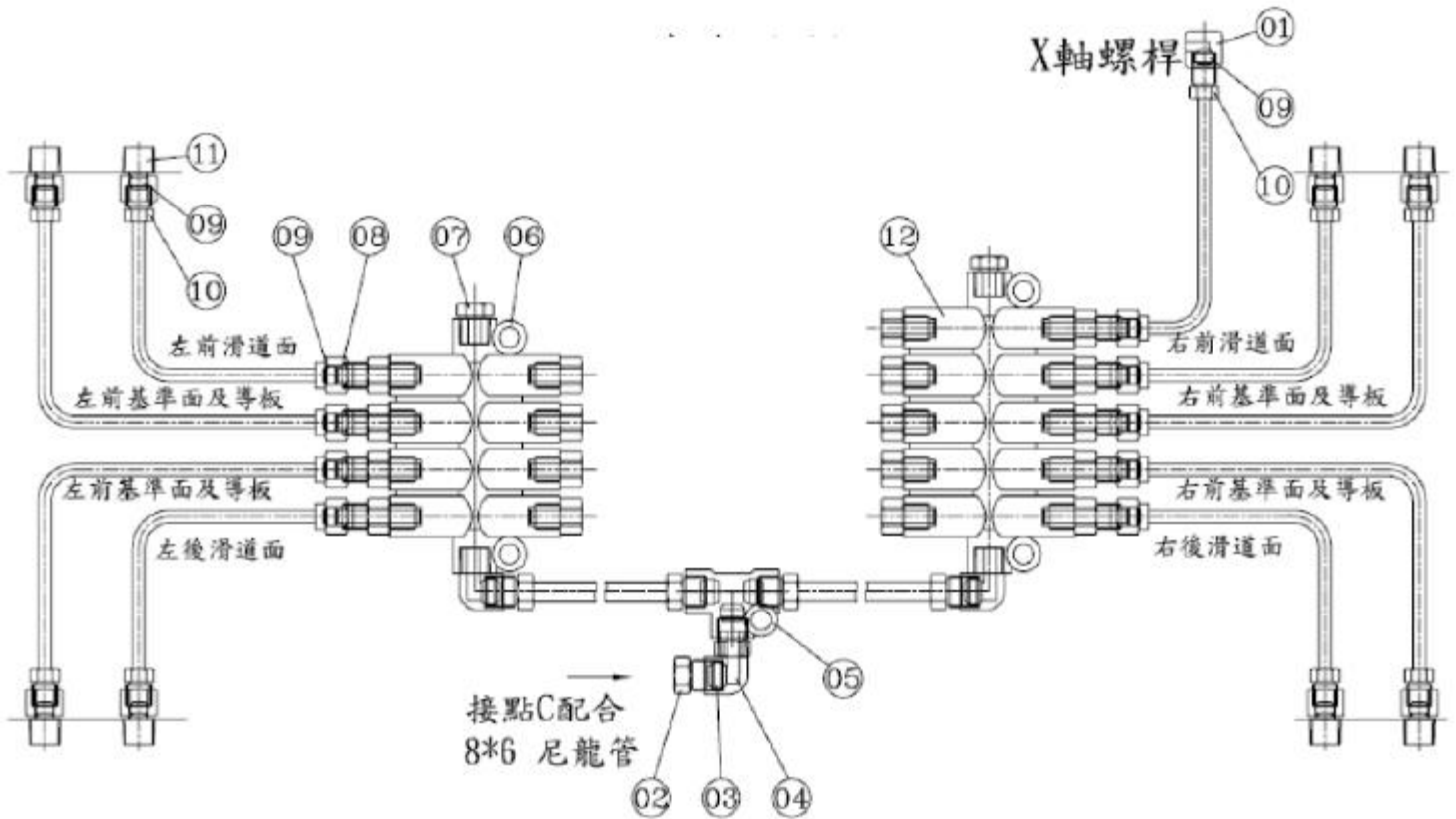

Item	Type	Eng - Name	Qty
1.	PH4-1	Street Elbow	1
2.	PB6	Nipple	7
3.	JD6	Coupling	1
4.	PH601	Street Elbow	3
5.	PKD6	Tee	1
6.	HBL-4	Quantitative Distributor	1
7.	PQ01	Plug	2
8.	PAN4	Nut	9
9.	PB4	Nipple	18
10.	PA4	Bushing	9
11.	PD401	Coupling	8
12.	HBL-5	Quantitative Distributor	1

2) SV6332

Connect B with oil tube

VL110-T065

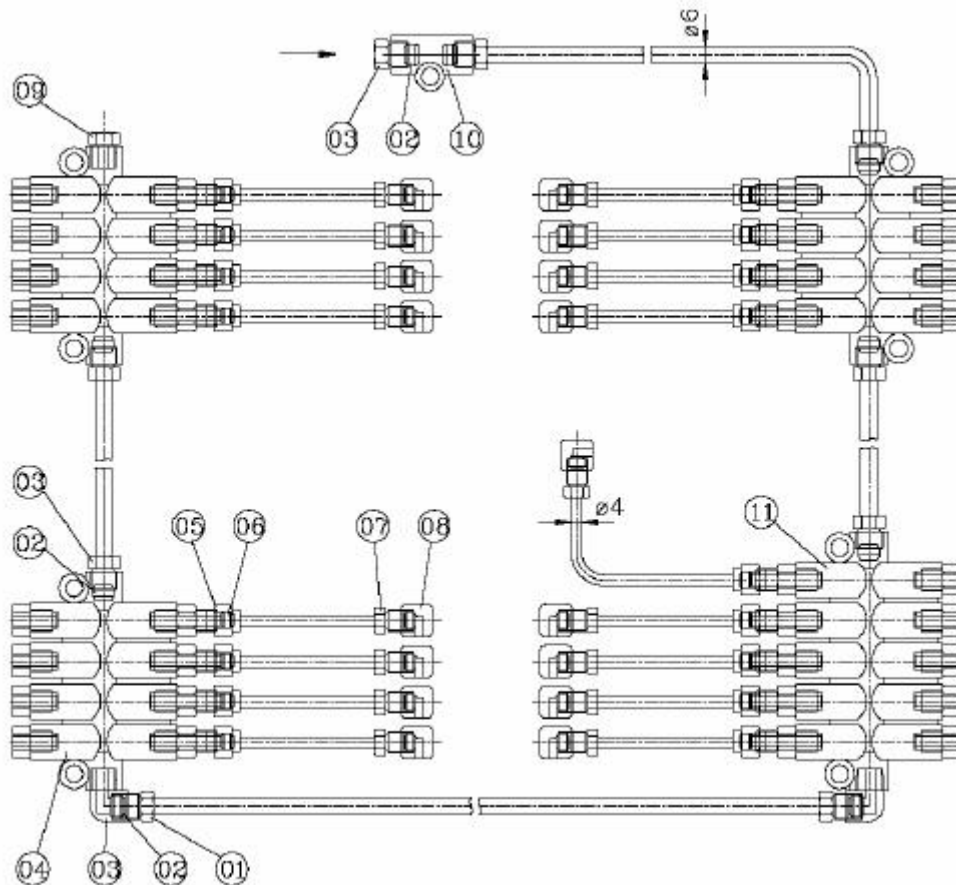

Item	Type	Eng - Name	Qty
1.	PA6	Coupling	9
2.	PB6	Nipple	9
3.	PH601	Street Elbow	2
4.	HBL-4	Quantitative Distributor	3
5.	PAN4	Nut	17
6.	PB4	Nipple	34
7.	PA4	Bushing	17
8.	PH4-1	Street Elbow	17
9.	PG01	Plug	1
10.	JD6	Coupling	1
11.	HBL-5	Quantitative Distributor	1

5.3 Spindle Distributor

1) SV4328 / SV5128

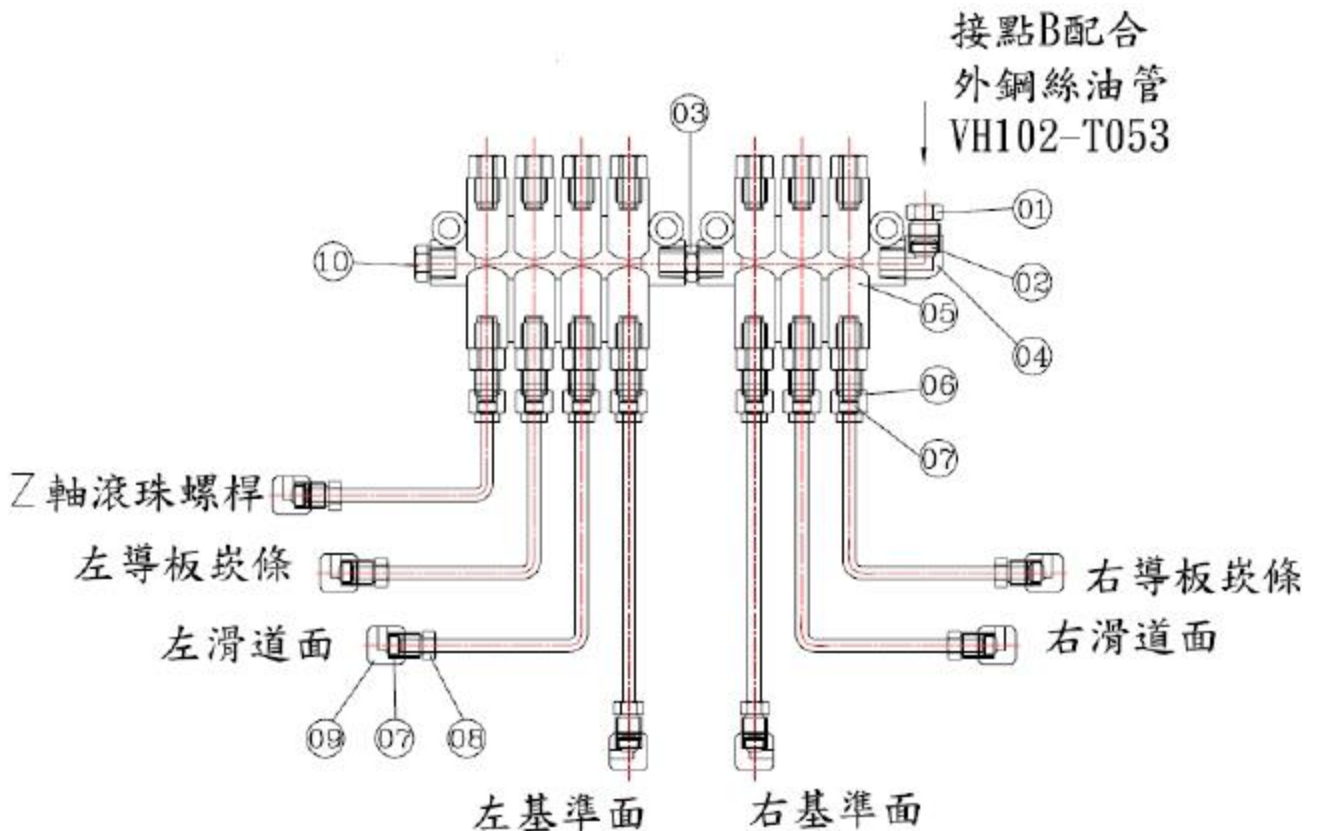

Item	Type	Eng - Name	Qty
1.	PA6	Bushing	1
2.	PB6	Nipple	1
3.	PQ101	Coupling	1
4.	PH601	Street Elbow	1
5.	HBL-3	Quantitative Distributor	1
6.	PAN4	Nut	7
7.	PB4	Nipple	14
8.	PA4	Bushing	7
9.	PH4-1	Street Elbow	7
10.	PG01	Plug	1

2) SV6332

Connect C with oil tube (VL110-T065)

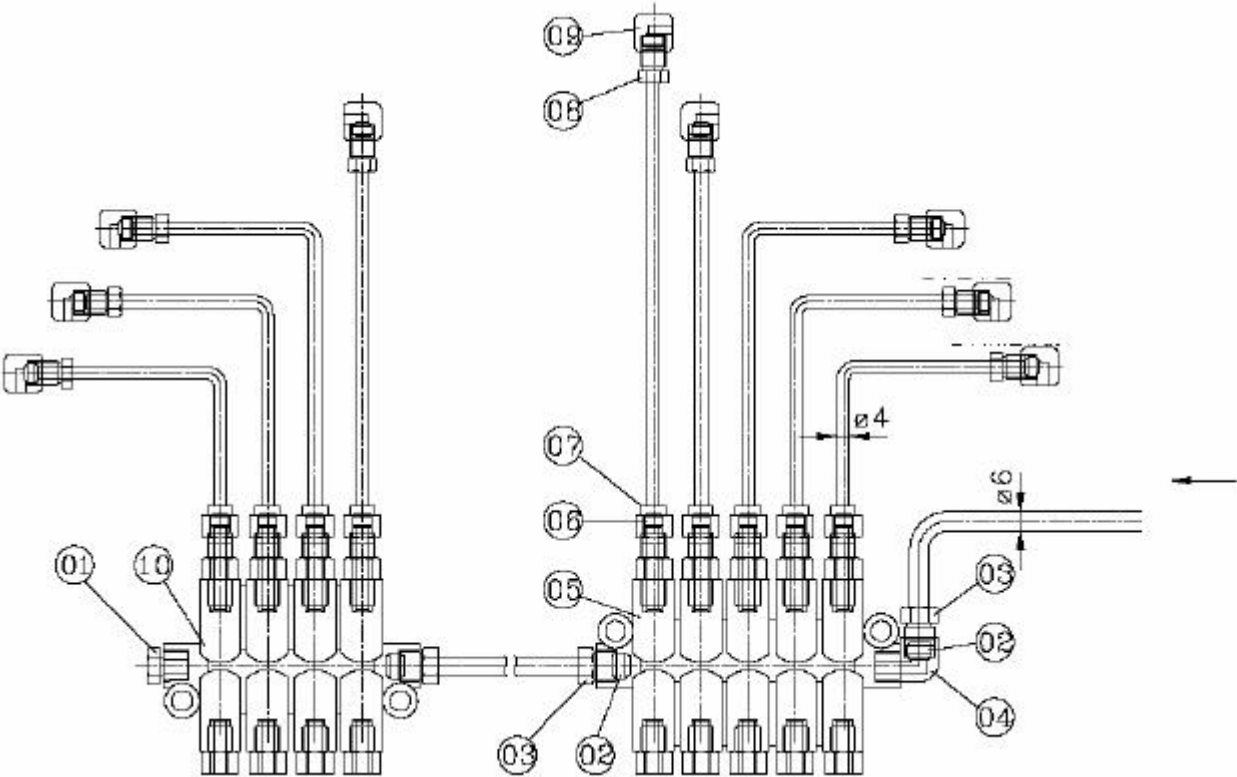

Item	Type	Eng - Name	Qty
1.	PG01	Plug	1
2.	PB6	Nipple	3
3.	PA6	Bushing	3
4.	PH601	Street Elbow	1
5.	HBL-5	Quantitative Distributor	1
6.	PB4	Nipple	14
7.	PAN4	Nut	7
8.	PA4	Bushing	7
9.	PH4-1	Street Elbow	7
10.	HBL-4	Quantitative Distributor	1

5.4 Auto lubrication System

1) SV4328 / SV5128

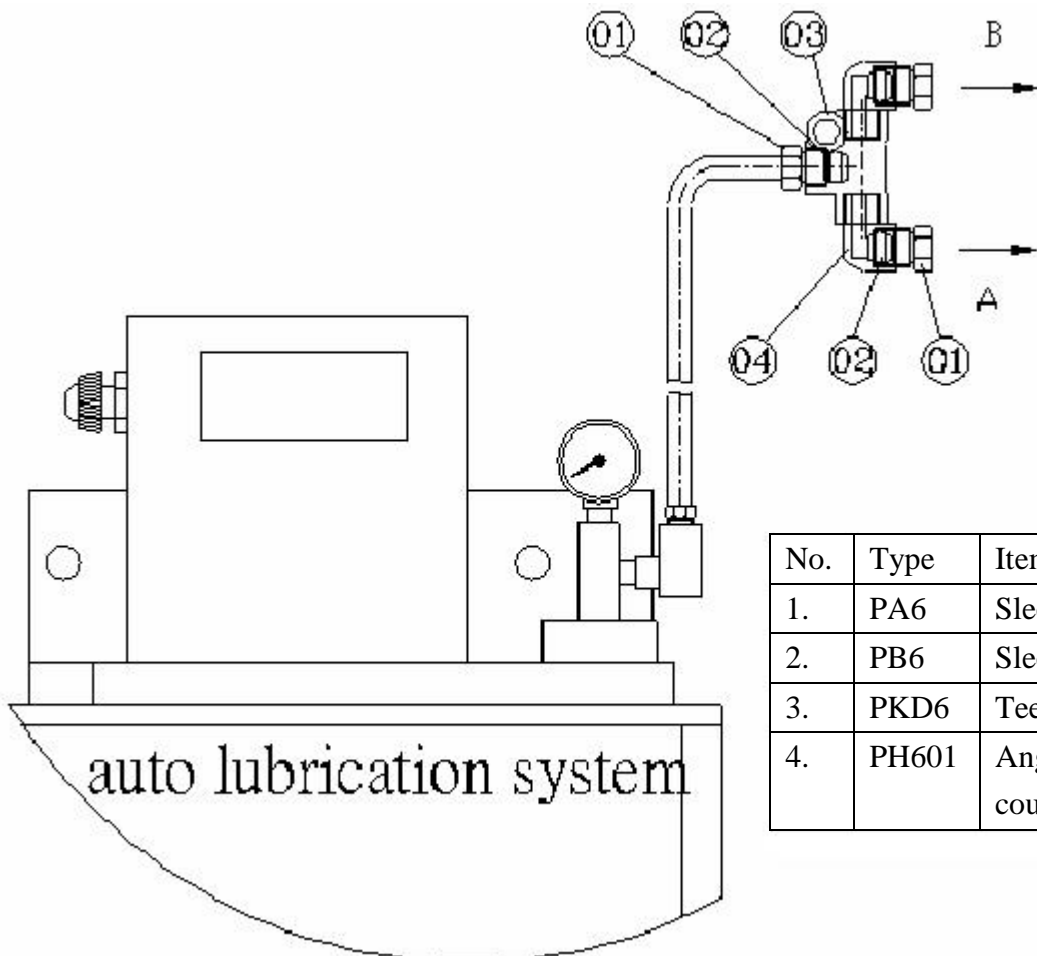

No.	Type	Item	Quantity
1.	PA6	Sleeve cap	3
2.	PB6	Sleeve	3
3.	PKD6	Tee	1
4.	PH601	Angle coupling	2

2) SV6332

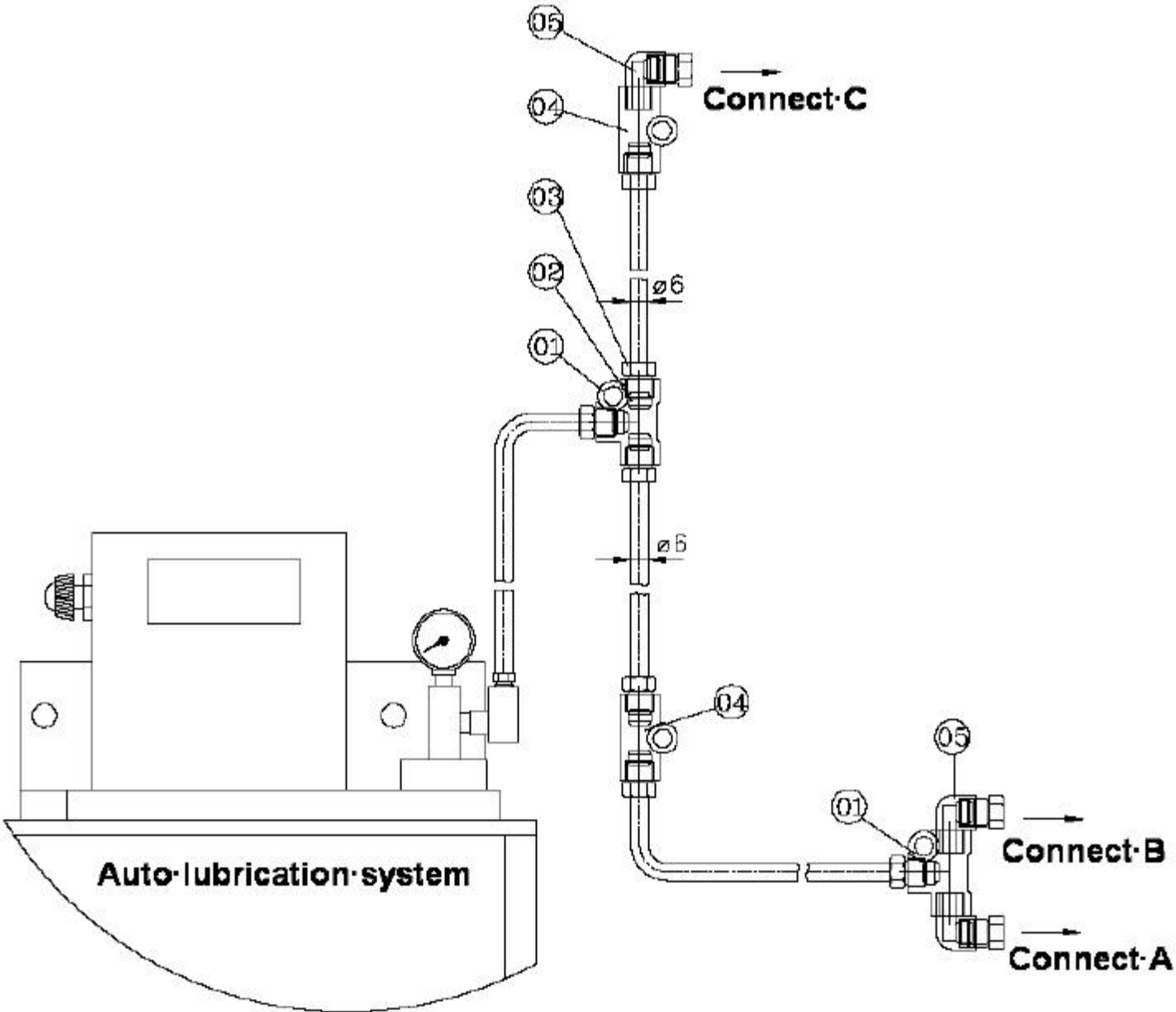

Item	Type	Eng - Name	Qty
1	PKD6	Tee	2
2	PB6	Nipple	10
3	PA6	Bushing	10
4	JD6	Coupling	2
5	PH4-1	Street Elbow	3

5.5 Lists of Recommended Lubricants for Parts

Item	Brand	Mobil	Shell	Esso	Casirol	CPC.
空氣壓力 Air pressure		Rarus 424	Corena S32	Teresso 32	Hyspin VG32 Perfecto T32	Circulation R32
硬潤滑油軌 Rail guide		Vactra 2	Tonna T68	Febis K68	Magna BD68	Way Lubricant68
線潤滑油軌 Linear guide		Vactra 1	Tonna T32	Febis K32	Magna GC32	Way Lubricant32
主軸油冷機 Spindle coolant		Velocite 10	Turbo T32	Spinesso 22	Hyspin VG32 Perfecto T32	Spindle R22
油壓箱 Oil pressure		DTE Light	Tellus 32	Nuto H32	Hyspin AWS32	Circulation R32
旋轉工作台 齒輪系統 Table & connected gear		Mobile Gard	Omala EP150	Spartan EP150	Alpha SP150	E.P. Lubricant HD150
主軸齒輪箱 Spindle motor & gear box		DTE Heavy DTE Medium	Tellus 68	Nuto H68	Alpha SP68	Circulation R68
ATC 凸輪箱 Arm & gear box		Mobile Gear 600 Mobile Gear 632	Omala EP320	Spartan EP320	Alpha SP320 Alpha EP320	E.P. Lubricant HD150

6. SPINDLE

1) SV4328 / SV5128

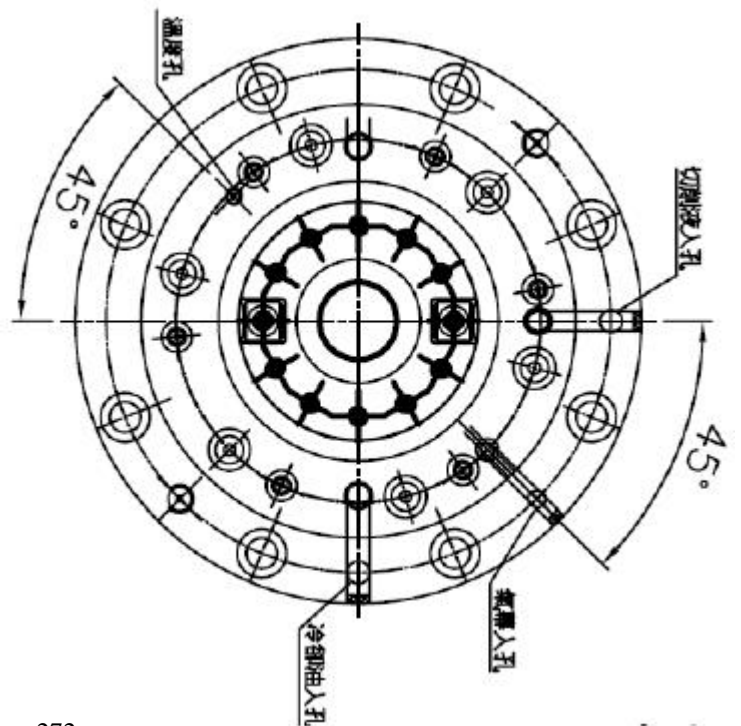
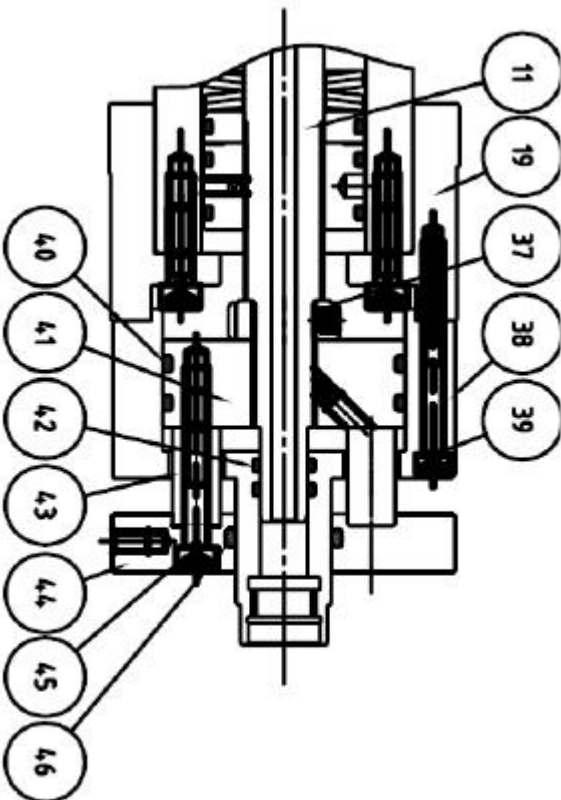
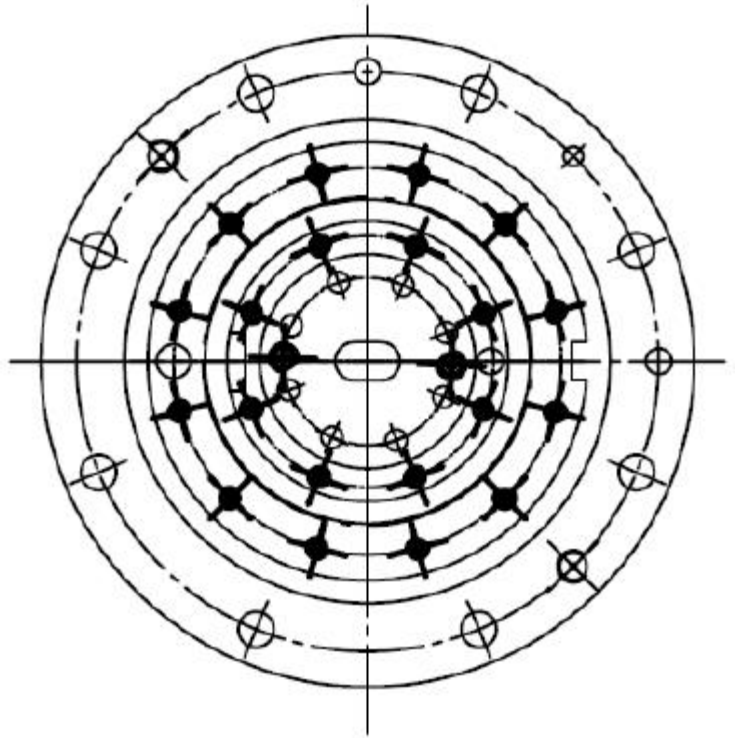
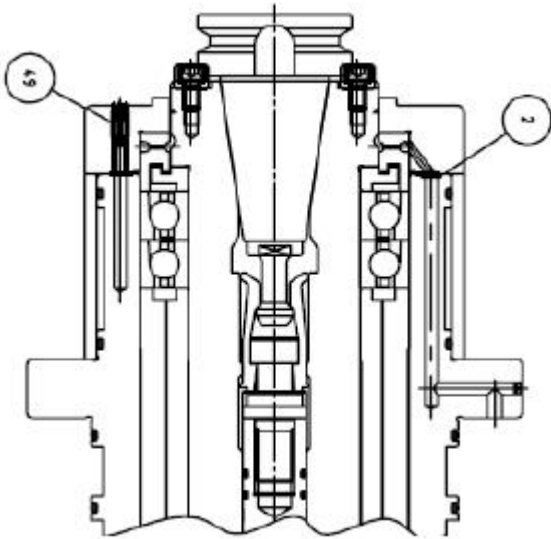

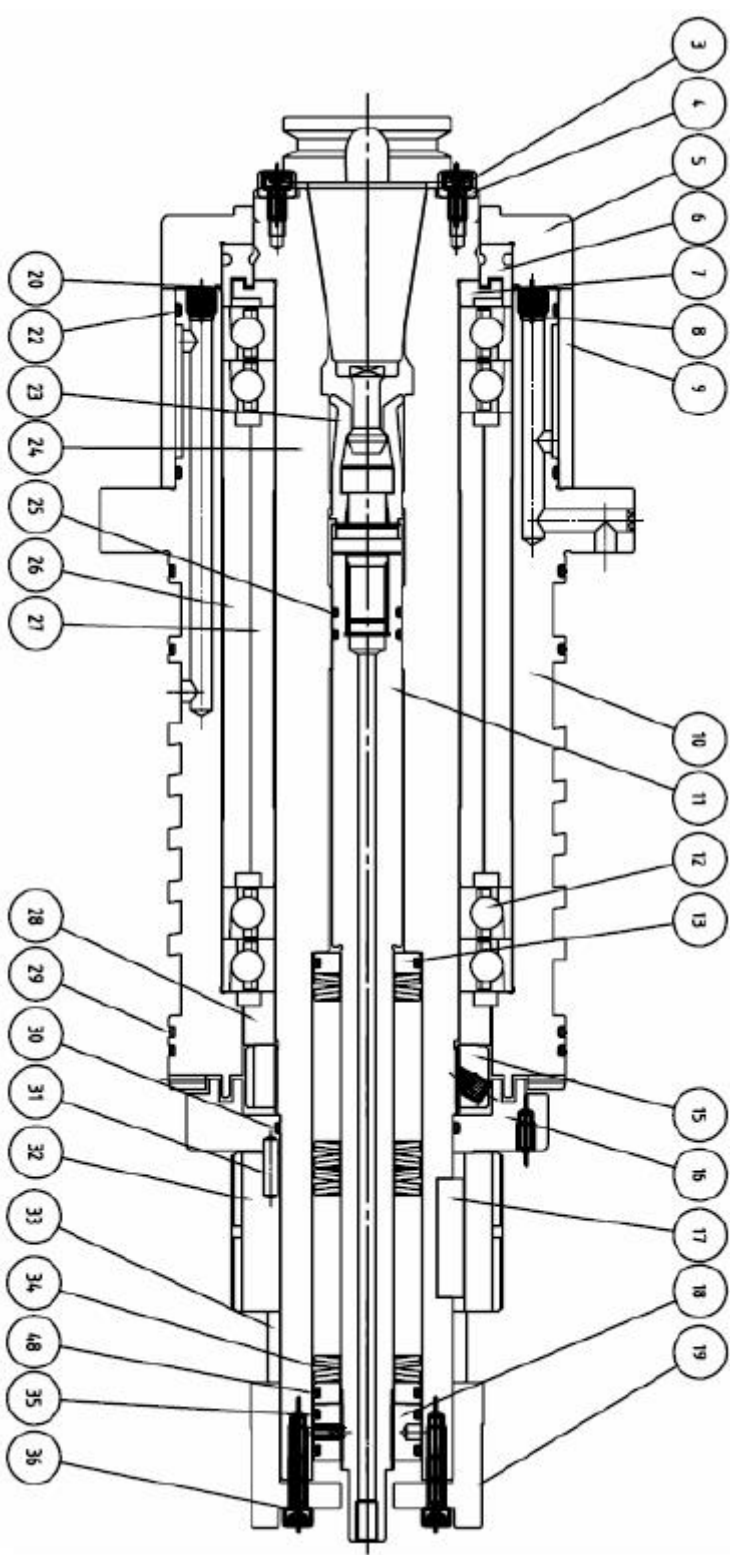
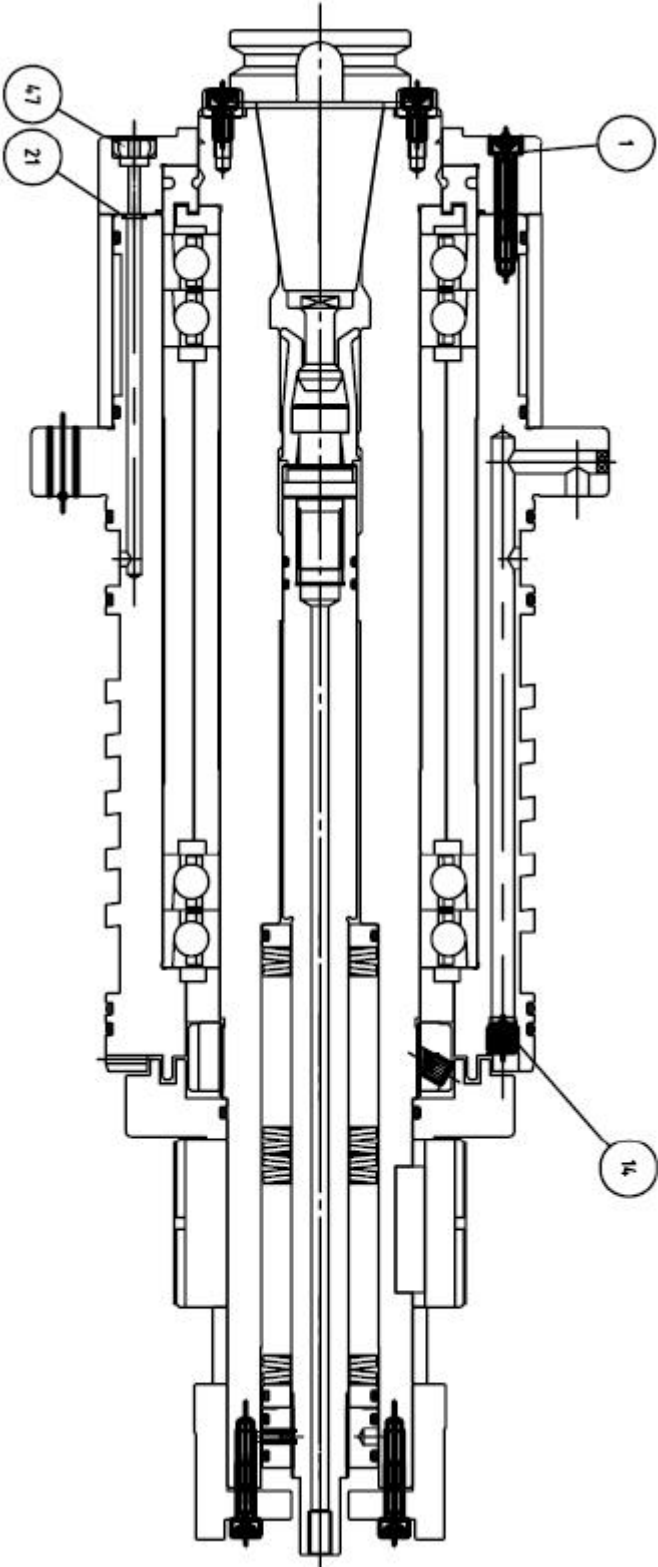

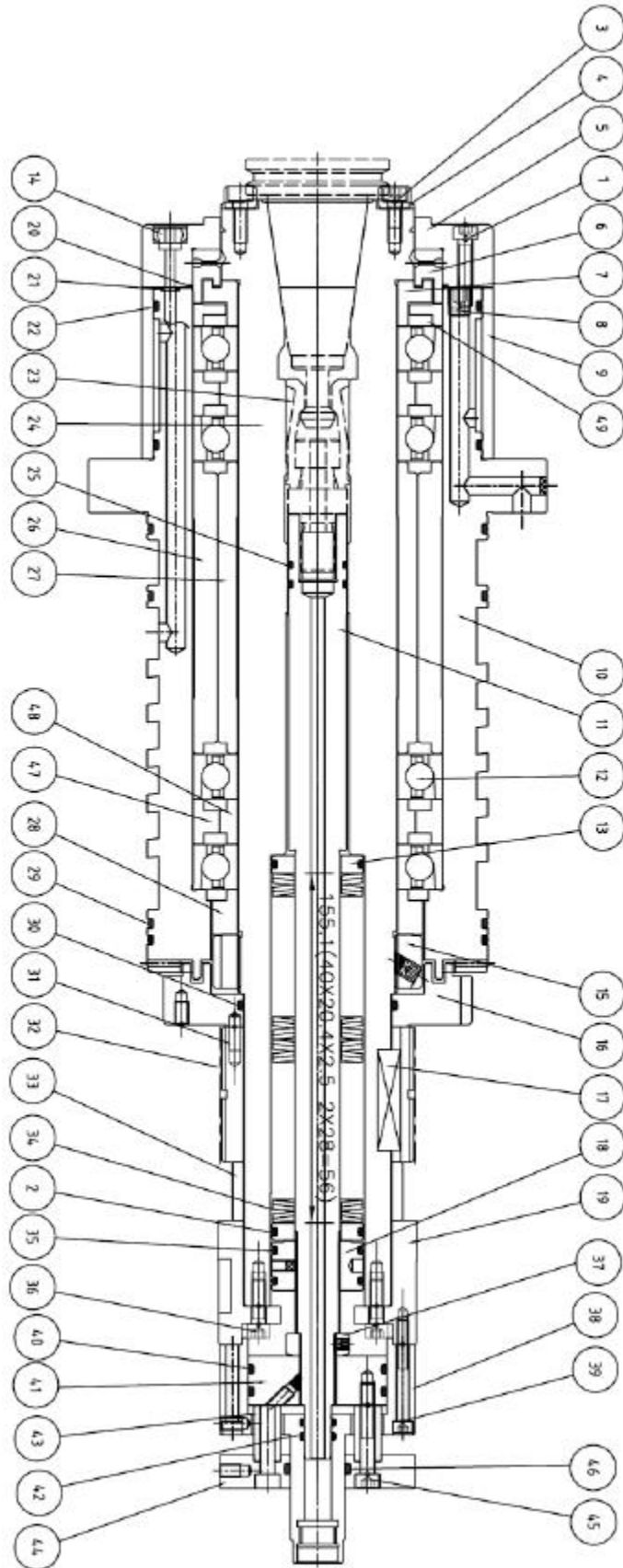

Item	NAME	SIZE	Qty	Item	NAME	SIZE	Qty
1	Hex Socket-Head Screw	M6xP1.0x30	6	33	Bush	R1267A	1
10	Spindle	R2059A	1	34	Disk Spring	40*20.4*2.5	56
11	Pull Stud	R1122D	1	35	O-Ring	ID34.7,W3.5	2
12	Steel Bearing	70BNR10STYNDUELP4	2	36	Hex Socket-Head Screw	M6xP1.0x35	8
13	Washer	R0013C	2	37	Nut	YSR M16*P1.5	1
14	Blot	SNA4(90101)	6	38	Adapter Seat	R1033D	1
15	Nut	YSF M70*P2	1	39	Hex Socket-Head Screw	M5xP0.8x45	6
16	Collar	R1266A	1	4	Fixed Key	R0021B	2
17	Round Key	R4180B	1	40	O-Ring	ID51.6,W5.7	2
18	Nut	R1314B	1	41	Nut	R1034C	1
19	Sensor Ring	R1152E	1	42	O-Ring	ID11.8,W2.4	2
2	O-Ring	ID29.7,W3.5	1	43	Bracket	R1035B	4
20	O-Ring	ID107.67,W1.78	1	44	Cylinder Seat	R1032D	1
21	O-Ring	ID4.8,W1.9	1	45	Hex Socket-Head Screw	M6xP1.0x40	4
22	O-Ring	ID134.4,W3.1	1	46	O-Ring	ID23.4,W3.1	1
23	Collect	BT40-45°(90003)	1	47	Collar	R0010A	2
24	Shaft	R8419A	1	48	Collar	R0008B	2
25	O-Ring	ID21.8,W2.4	2	49	Collar	R5054A	1
26	Collar	R5198A	1	5	Cover	R2062A	1
27	Collar	R5199A	1	6	Collar	R0006B	1
28	Collar	R1114A	1	7	Collar	R5055A	1
29	O-Ring	ID139.4,W3.1	4	8	Plug	PT1/8	3
3	Hex Socket-Head Screw	M6xP1.0x20	2	9	Jacketing	R1271A	1
30	O-Ring	ID64.4,W3.1	1				
31	Spring Pin	φ5x16	2				
32	Belt Pulley	R1265B	1				

2) SV6332

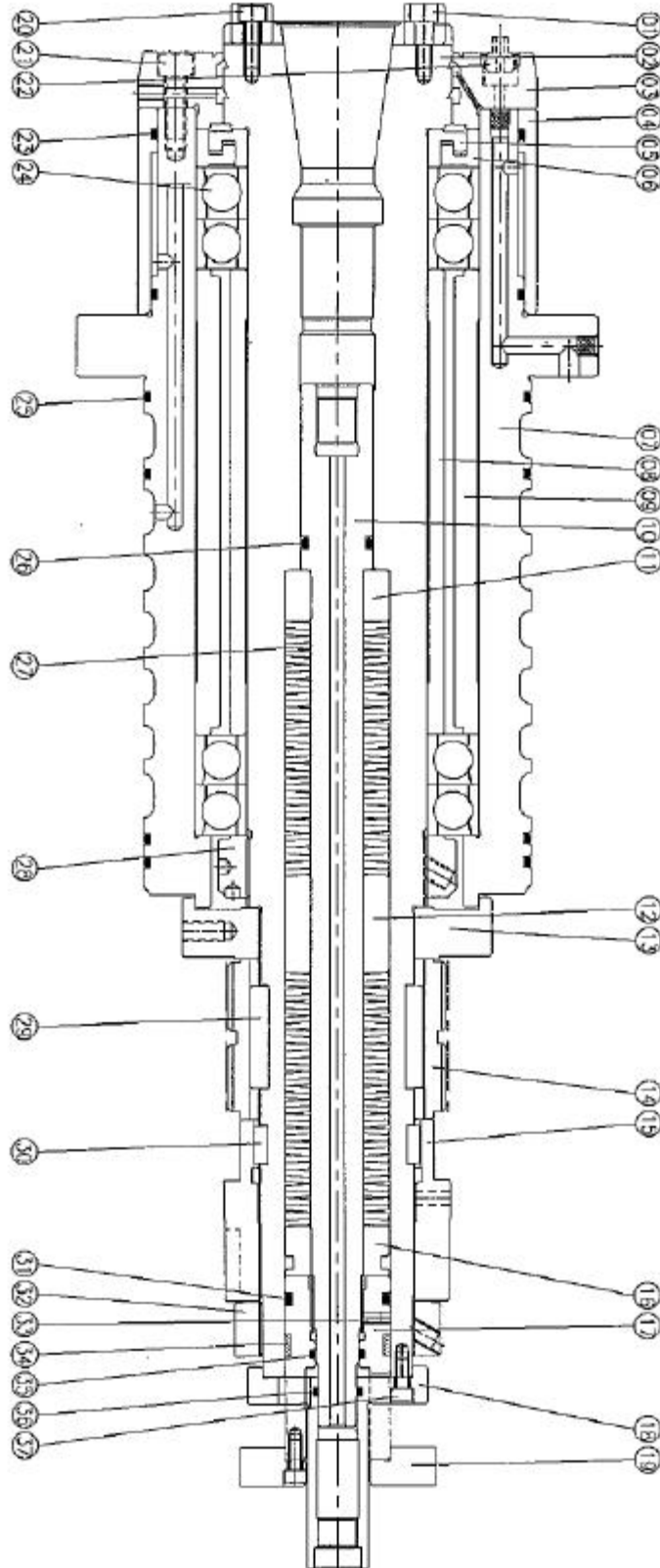

Item	NAME	SIZE	Qty	Item	NAME	SIZE	Qty
1	Driver Key	#40	2	21	Hex socket- head screw	M8*P1.25*25	6
2	Shaft	V10F02	1	22	Blot	6*6L	6
3	Cover	V10E03	1	23	O-Ring	G140	2
4	Jacketing	KC14008-A	1	24	Bearing	70BNR10H	1
5	Collar	KC141005	1	25	O-Ring	G145	4
6	Collar	KC141004	1	26	O-Ring	P22A	1
7	Spindle body	V10E01	1	27	Disk spring	40*20.4*2.5	72
8	Collar	KCA141011C	1	28	Nut	YSF M70*P2.0	1
9	Collar	KCA141012C	1	29	Round key	8*7*40L	2
10	Pull stud	V10F17	1	30	Round key	5*5*15L	2
11	Washer	KC141025B	1	31	O-Ring	P35	1
12	Washer	V10A25	1	32	Nut	M60*P1.5	1
13	Collar	V10F07	1	33	Hex socket screw - no head	M5*P0.8*8L	4
14	Pulley	V10F13	1	34	Collar	WRS-08	1
15	Bush	V10F15	1	35	O-Ring	P16	1
16	Washer	KC141025F	1	36	O-Ring	P15	1
17	Nut	KCA141019H	1	37	Hex socket- head screw	M5*P0.8*12L	12
18	CTS connector	V10F29	1				
19	Cylinder Seat	V10F30	1				
20	Hex socket-head screw	M6 * P1.0*18	2				

7. MAGAZINE

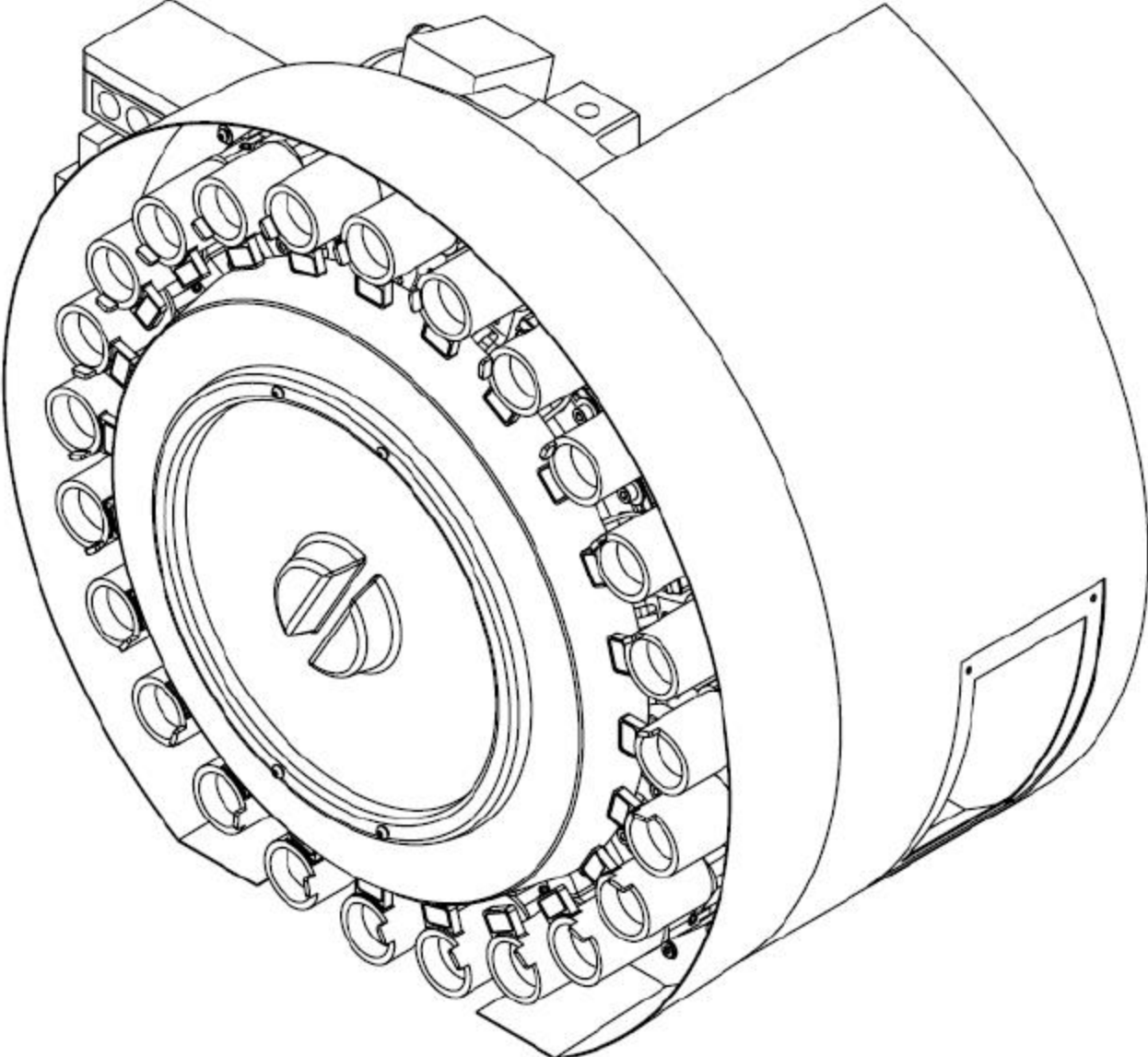

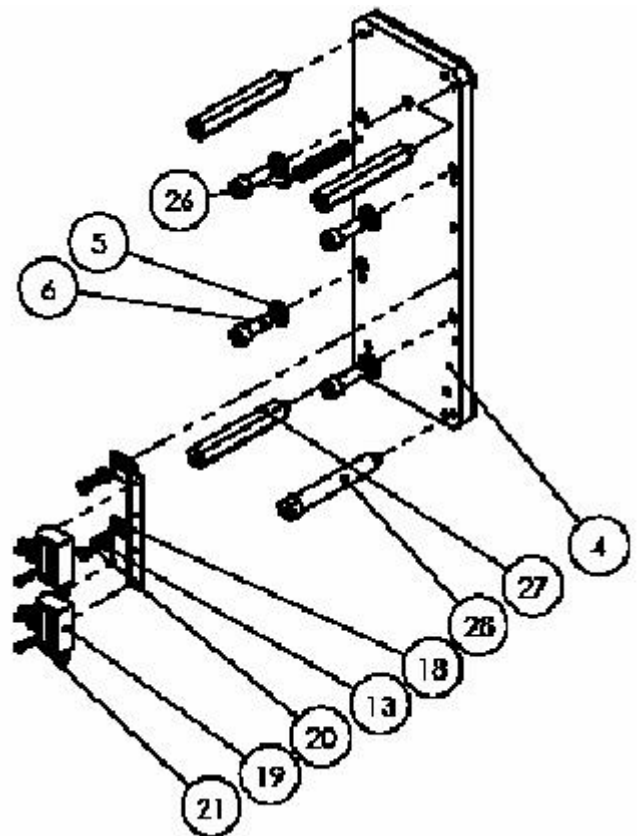
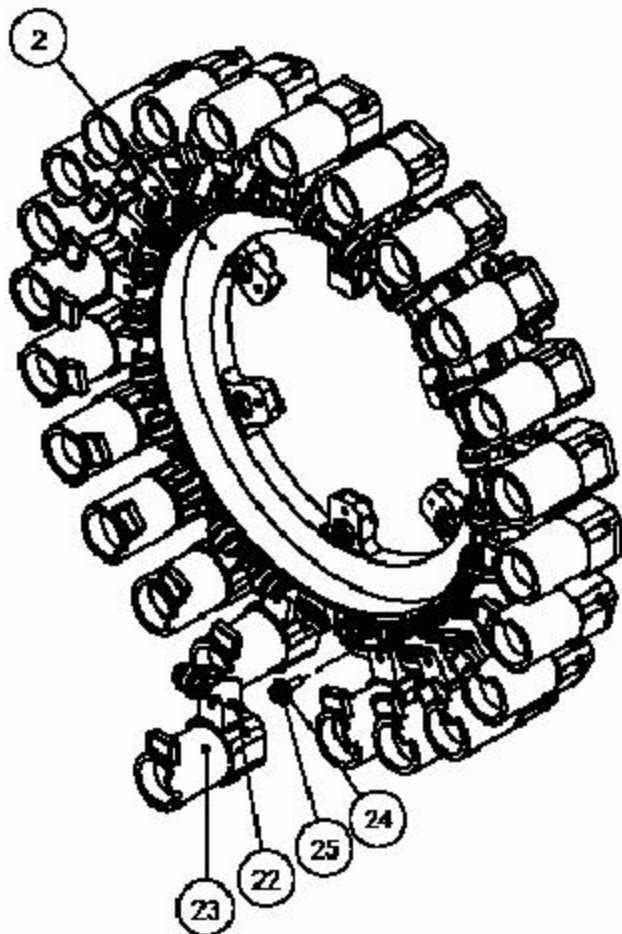
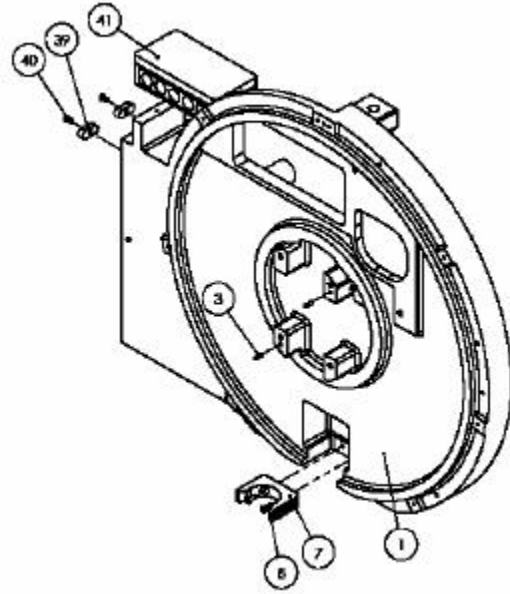
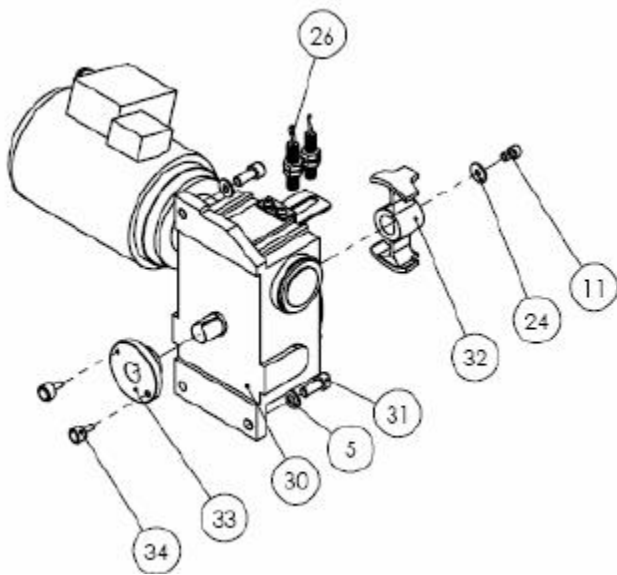

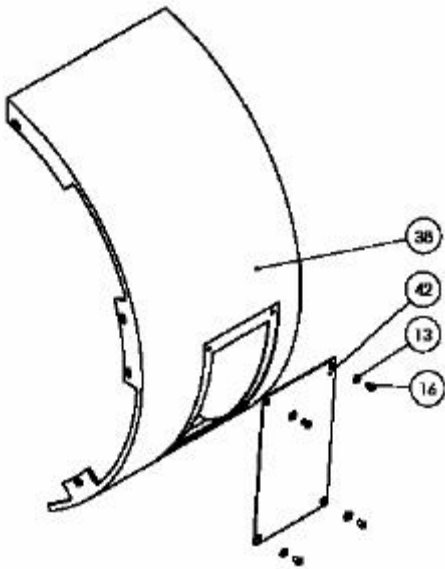
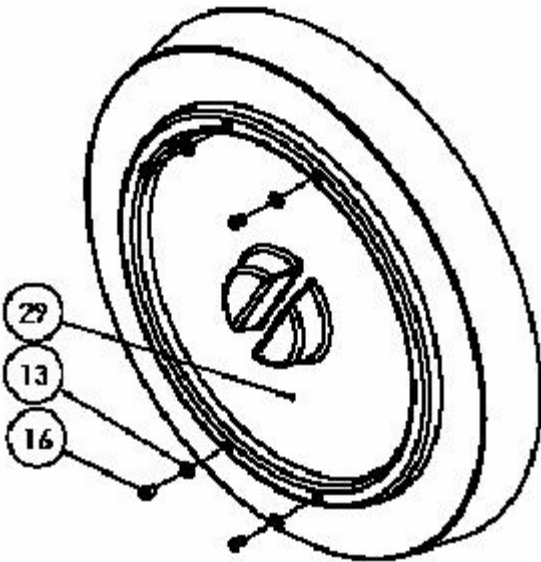
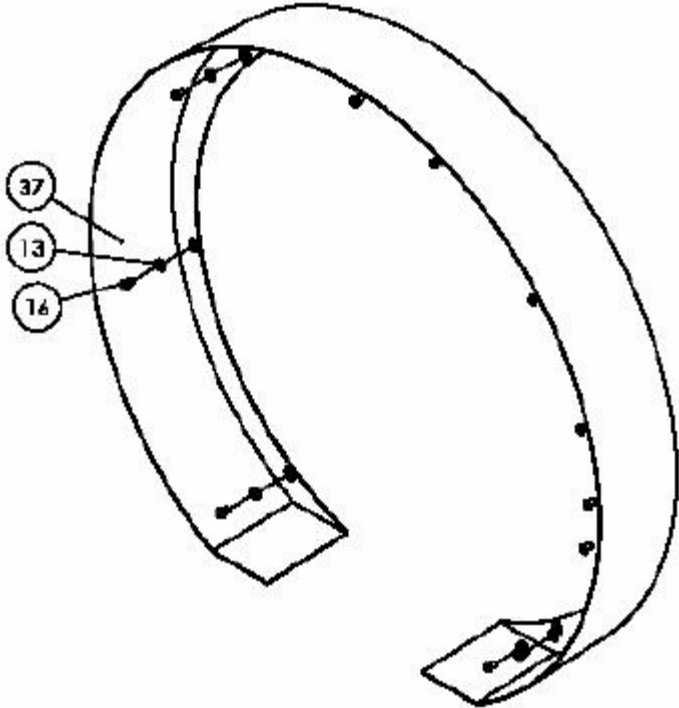
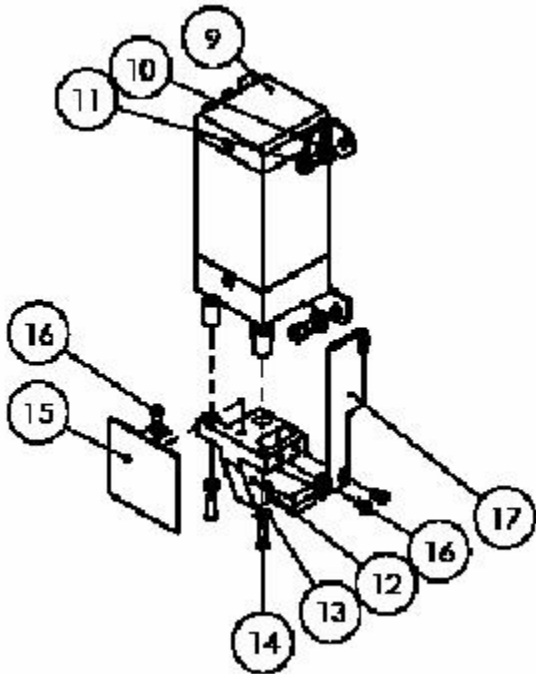

ITEM NO.	QTY.	MATERIAL	TITLE-C	TITLE-E	NOTE
1	1	FC30	刀庫本體	Main Body	
2	1		刀盤組	Tool disk module	
3	2		平行銷	Paralle Pin	
4	1		壓缸固定板組	Cylinder Mounting Plate Module	
5	7		平墊圈	Finished Circular Plain Washer	
6	4		內六角承窩頭螺栓	Hexagon Socket Head Screw	
7	1	尼龍6+礦纖維40%	倒刀定位座	POCKET POSITIONING SEAT	
8	2		圓頭內六角承窩頭螺絲	Hexagon Socket Button Head Screw	
9	1	市購品	倒刀壓缸	Pneumatic Cylinder	
10	4		平墊圈	Finished Circular Plain Washer	
11	5		內六角承窩頭螺栓	Hexagon Socket Head Screw	
12	1	S45C	倒刀塊	TOOL TILT BLOCK	
13	26		平墊圈	Finished Circular Plain Washer	
14	2		圓頭內六角承窩頭螺絲	Hexagon Socket Button Head Screw	
15	1	SS41(2t)	倒刀蓋板	Cover Plate	
16	24		圓頭內六角承窩頭螺絲	Hexagon Socket Button Head Screw	
17	1	SS41(4t)	極限開關碰塊	Limit Switch Sensing Dog	
18	1	SS41	極限開關固定板	LIMIT SWITCH BLOCK	
19	2	YAMAATAKE(LS1-A)	極限開關	LIMIT SWITCH	
20	2		內六角承窩頭螺栓	Hexagon Socket Head Screw	
21	4		內六角承窩頭螺栓	Hexagon Socket Head Screw	
22	24	S45C	刀套固定桿	Shaft	
23	24		BT40刀套(65度)	Pocket	
24	25	市購品	墊片	Washer	
25	24		內六角承窩頭螺絲	Hexagon Socket Head Screw	
26	3	市購品	近接開關	Proximity Sensor	
27	3	SS41	前蓋支撐桿	Support Rod	
28	1	六角鐵	前蓋支撐桿	Support Rod	
29	1	SS41	壓缸前蓋	COVER	
30	1	市購品	渦輪減速機馬達(220V)	Worm Gear Motor(220V)	
31	3		內六角承窩頭螺絲	Hexagon Socket Head Screw	
32	1	SS41	定位感應片	SS41	
33	1	S45C	驅動軸	Tool Disk Driver	
34	2	CF6	曲線滾輪	ROLLER	
37	1	ABS	刀庫前外罩	Mag. front cover	
38	1	FRP	刀庫後外罩	Mag. after cover	
39	2	S45C	承靠塊	Positioning Key	
40	2		圓頭內六角承窩頭螺絲	Hexagon Socket Button Head Screw	
41	1	PS-1809-6	CE 電控盒	CE ELECTRIC BOX	
42	1	壓克力	鍍金視窗	WINDOW	

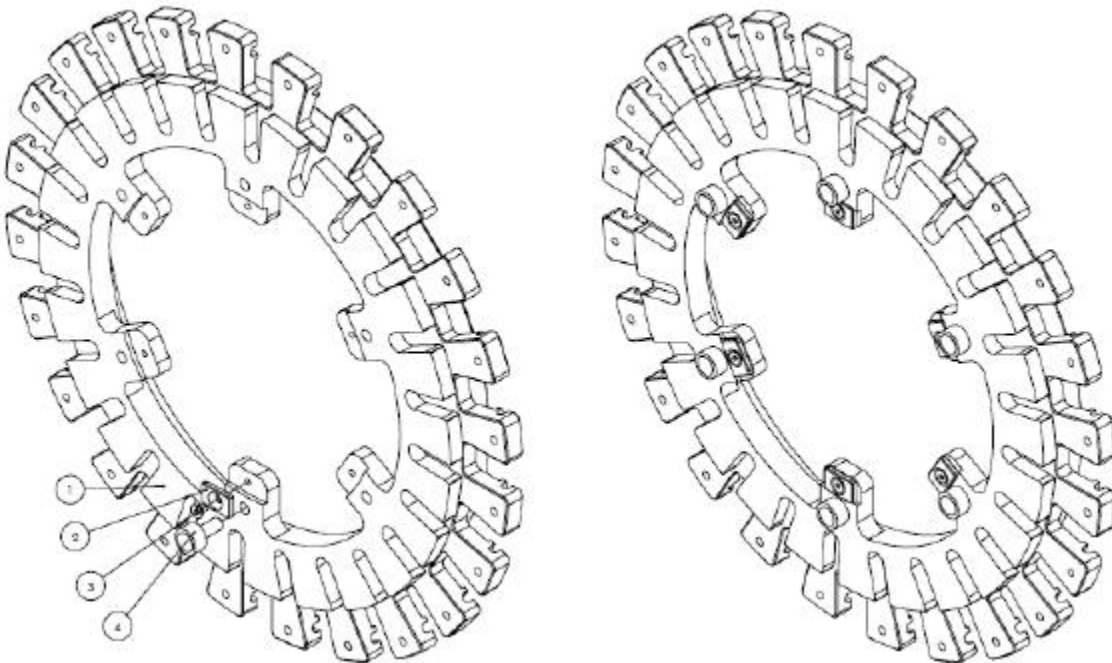

ITEM NO.	QTY.	MATERIAL	TITLE-C	TITLE-E	NOTE
1	1	FC30	刀盤	Tool Disk	
2	6	POM聚縮醛樹脂CL-500CL	耐磨片(I)	Wear resistant Strip(I)	
3	6		內六角皿頭螺栓	Socket Countersunk Head Screw	
4	6	CF10	曲線滾輪軸承	ROLLER	

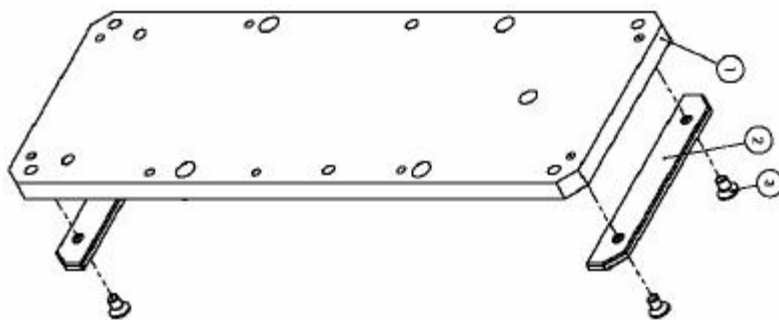

ITEM NO.	QTY.	MATERIAL	TITLE-C	TITLE-E	NOTE
1	1	SS41	壓缸固定板	Cylinder Mounting Plate	
2	2	UP	耐磨片(II)	Wear resistant Strip(II)	
3	4		內六角皿頭螺栓	Socket Countersunk Head Screw	

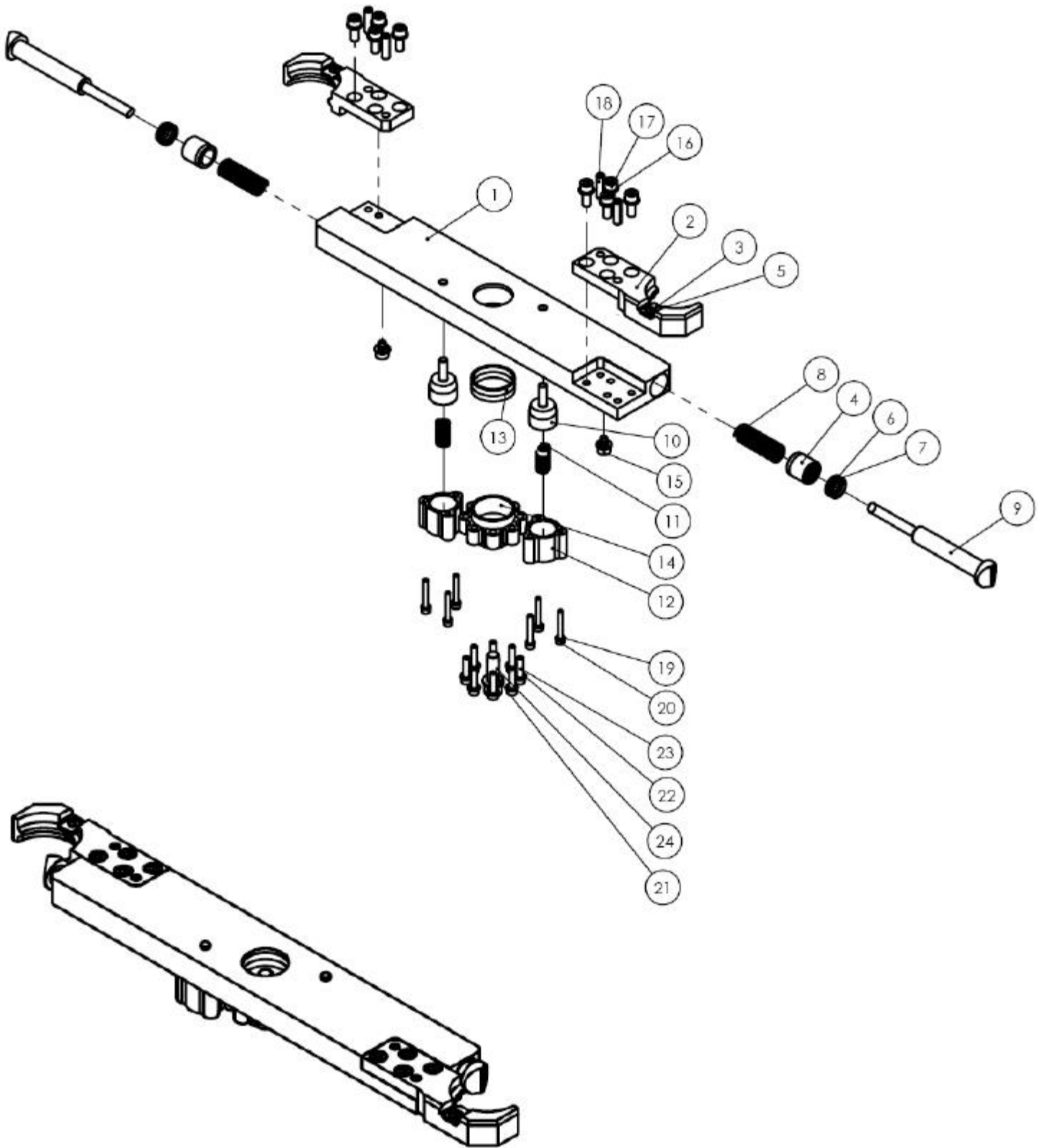

ITEM NO.	PART NO.	QTY.	MATERIAL	TITLE-C	TITLE-E	NOTE
1	A40C-0001B08	1	SS41	刀臂本體	MAIN BODY	
2	A40C-0002A03	2	S50C	扣刀爪	Gripper(BT)	
3	A40C-0004A01	2	S45C	定位鍵	KEY(BT,CAT,DIN)	
4	A40C-0020A06	2	粉末冶金	銅套	COPPER COVER	
5	M5XP0.8X12L	2		內六角皿頭螺栓	Socket Countersunk Head Screw	
6	OR0000000P18	2	P18	O型環	O-RNIG	
7	OT00000SER18	2	SER-18	刮刷環	SEAL	
8	A40C-0007A02	2	SWPB	頂刀爪彈簧	FINGER SPRING	
9	A40C-0003B06	2	S50C	頂刀爪(R265)	Finger	
10	A40C-0005A03	2	S45C	安全頂銷	SAFETY PIN	
11	A40C-0008A02	2	SWPB	安全頂銷彈簧	PIN SPRING	
12	A40C-0006A04	2	SS41	彈簧蓋板	SPRING COVER	
13	CX0000d40D45	2		迫緊環	TAPER SNAP RING	
14	A40C-0009A03	1	SCM4	迫緊環蓋	COX COVER	
15	A40C-0013A03	2	市購品	頂刀爪限位銷	SKT,HD,CAP SCR	
16	M8	10		彈簧墊圈	Spring Lock Washer	
17	M8XP1.25X20L	8		內六角承窩頭螺栓	Hexagon Socket Heard Screw	
18	M8x28L	4		彈簧銷	Spring Pin	
19	M5	6		彈簧墊圈	Spring Lock Washer	
20	M5XP0.8X35L	6		內六角承窩頭螺栓	Hexagon Socket Heard Screw	
21	M12	1		彈簧墊圈	Spring Lock Washer	
22	M6	8		彈簧墊圈	Spring Lock Washer	
23	M6XP1X25L	8		內六角承窩頭螺栓	Hexagon Socket Heard Screw	
24	M12XP1.75X35L	1		內六角承窩頭螺栓	Hexagon Socket Heard Screw	

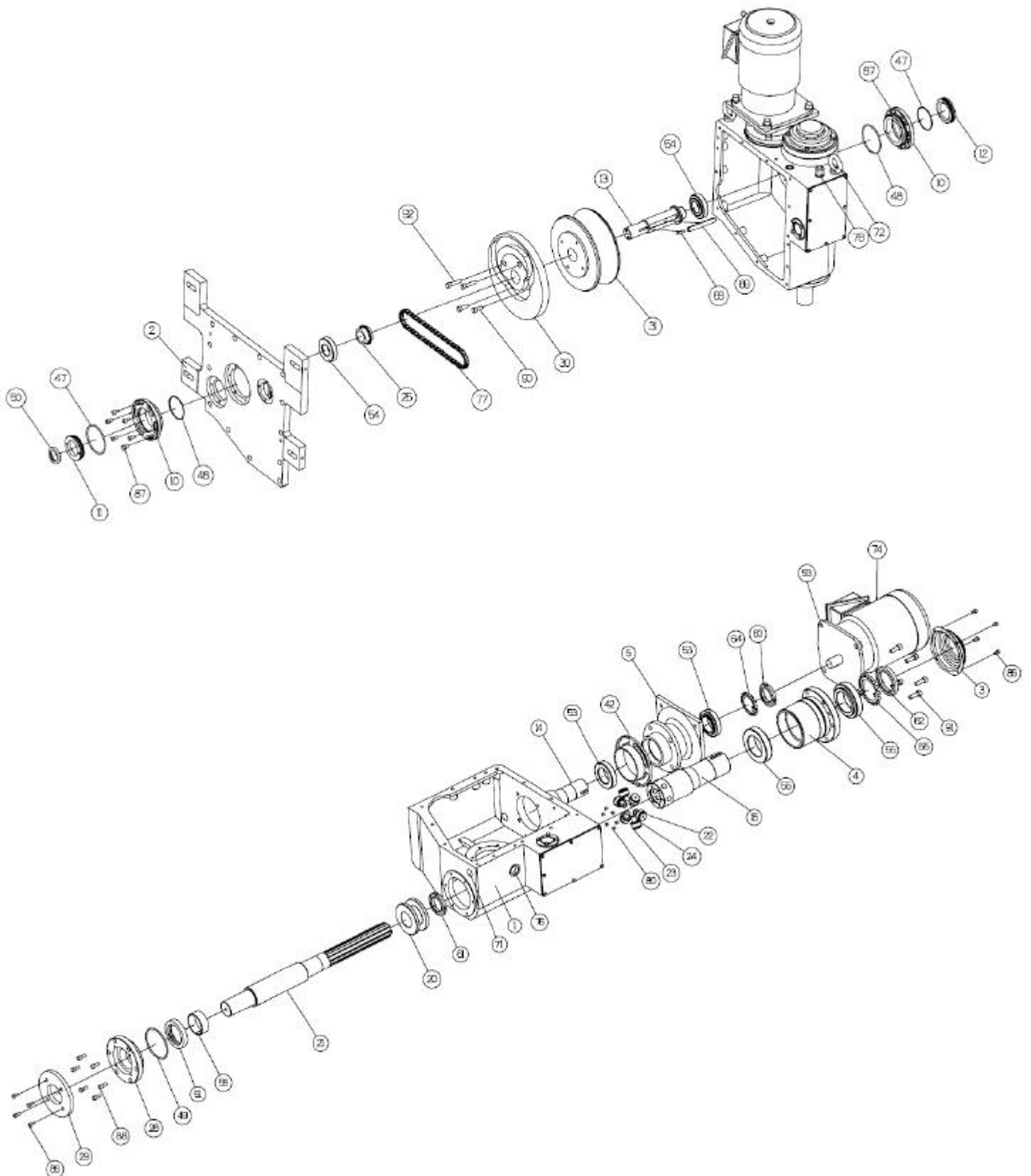

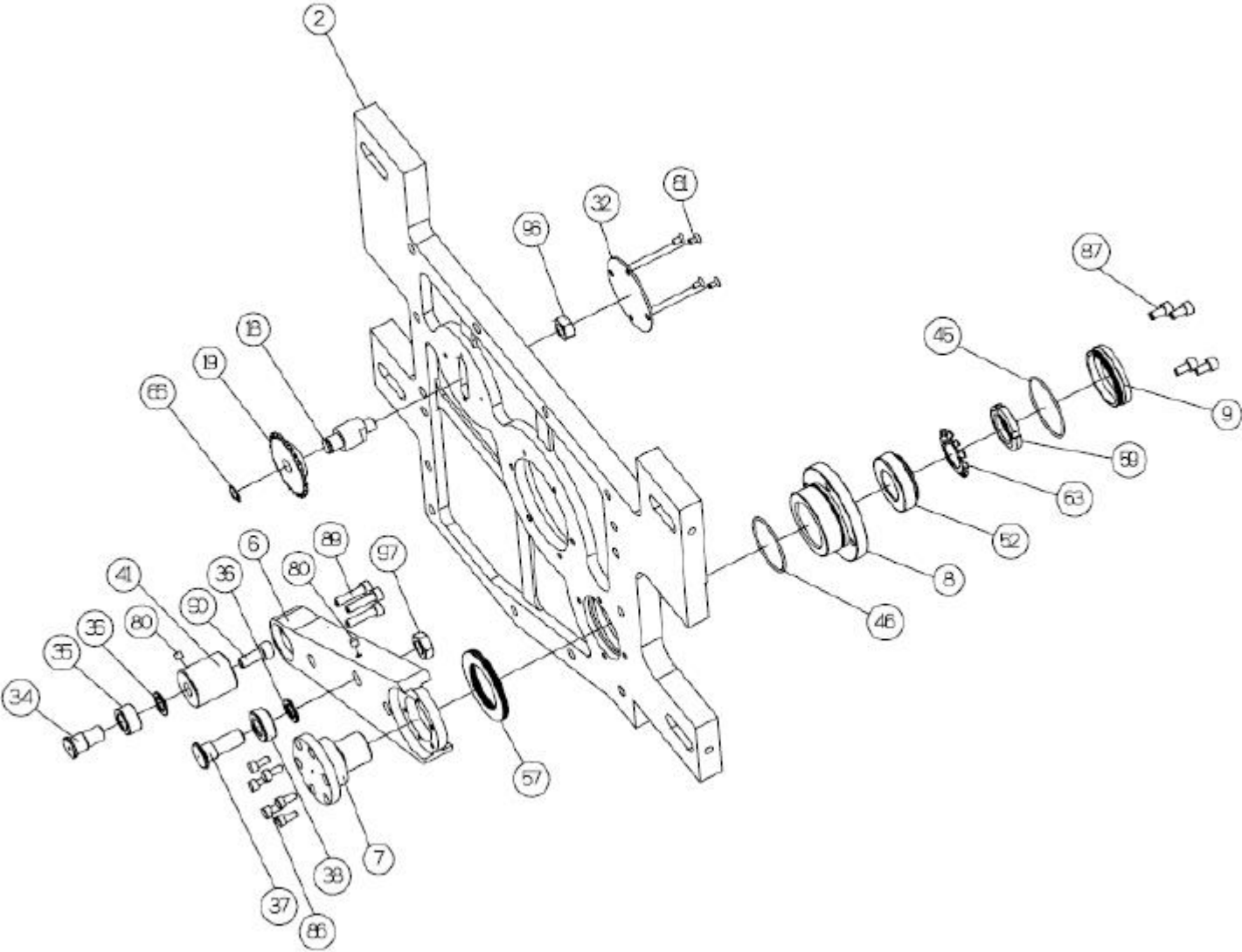

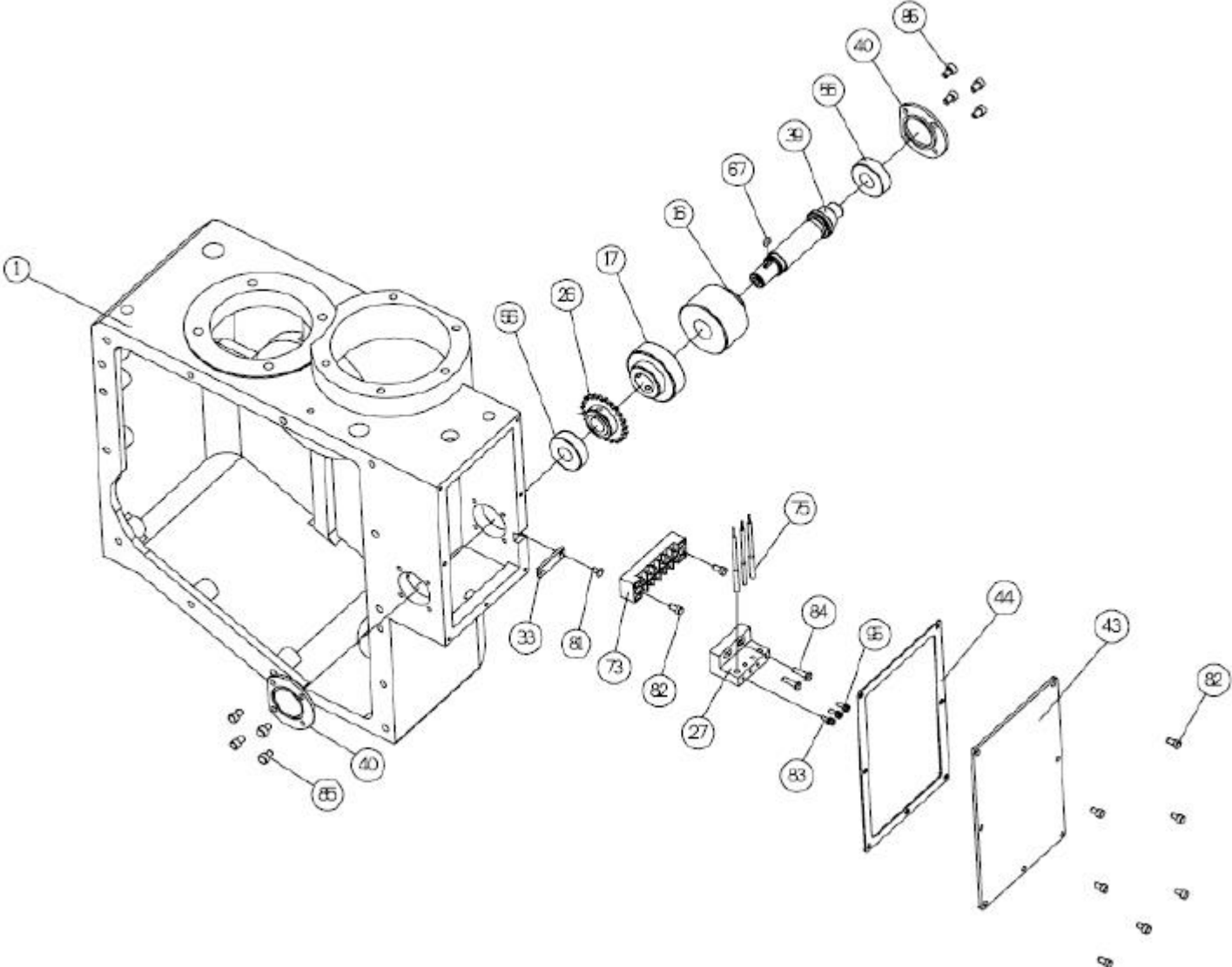

NO.	Parts No.	Specification	Q'TY	NO.	Parts No.	Specification	Q'TY
1	A01-001	Cambox	1	25	A01-023	Chain Wheel	1
2	A01-002	Box Cover	1	26	A01-024	Chain Wheel	1
3	A01-003	Cover	1	27	A01-025	Proximity Switch Holder	1
4	A01-004	Bearing Bracket	1	28	A01-126	Shaft Bracket	1
5	A01-005	Motor Bracket	1	29	A01-027	Flange	1
6	A01-006	Move Arm	1	30	A01-028	Plate Cam	1
7	A01-007	Arm Shaft	1	31	A01-029	Roller Gear Cam	1
8	A01-008	Arm Bracket	1	32	A01-031	Cover	1
9	A01-009	Cover	1	33	A01-032	Position indicator	1
10	A01-010	Bearing Bracket	2	34	A01-033	Needle Bearing	1
11	A01-011	Cover	1	35	A01-133	Ring	1
12	A01-012	Cover	1	36	A01-233	Washer	2
13	A01-013	Cam Shaft	1	37	A01-034	Needle Bearing	1
14	A01-014	Driving Gear	1	38	A01-134	Ring	1
15	A01-015	Turret	1	39	A01-035	Dog Shaft	1
16	A01-016	Checking Dog	1	40	A01-036	Cover	2
17	A01-017	Braking Dog	1	41	A01-037	Needle Bearing Holder	1
18	A01-018	Idle Wheel Shaft	1	42	A01-038	Adjusting Ring	1
19	A01-019	Idle Wheel	1	43	A01-040	Cover	1
20	A01-020	Fork	1	44	A01-052	Rubber Seal	1
21	A01-021	Spring Shaft	1	45	AS031	O Ring	1
22	A01-022	Needle Bearing	6	46	AS033	O Ring	1
23	A01-122	Ring	6	47	AS035	O Ring	2
24	A01-222	Washer	6	48	G75	O Ring	2

NO.	Parts No.	Specification	Q'TY	NO.	Parts No.	Specification	Q'TY
49	G80	O Ring	1	73	6P	Terminal Block	1
50	TC30427	Oil Seal	1	74	3/4HP	Motor	1
51	T34 507212	Oil Seal	1	75	E2E-CR8B1	Sensor	3
52	32005	Roller Bearing	1	76		Oil Gauge	1
53	32008	Roller Bearing	2	77	RS25x597L(94)	Chain	1
54	30206	Roller Bearing	2	78	M10x1.5	Cable Gland	1
55	32011	Roller Bearing	2	79	M5x6	Set Screw	5
56	6202ZZ	Ball Bearing	2	80	M6x5	Set Screw	14
57	NTB40603	Thrust Bearing	1	81	M4x6	Screw	5
58	L3B5020	Bearing	1	82	M4x8	Screw	9
59	AN05	Locking Nut	1	83	M4x10	Screw	3
60	AN08	Locking Nut	1	84	M4x16	Cable Gland	2
61	AN08	Locking Nut	1	85	M5x8	Set Screw	12
62	AN11	Locking Nut	2	86	M5x12	Set Screw	10
63	AW05	Washer	1	87	M6x12	Screw	16
64	AW08	Washer	1	88	M6x16	Screw	6
65	AW11	Washer	1	89	M6x25	Screw	3
66	S12	Ring	1	90	M8x20	Screw	3
67	4x8x4mm	Key	1	91	M8x25	Screw	18
68	5x20x5mm	Key	1	92	M8x35	Screw	2
69	10x85x8mm	Key	1	93	M10x25	Screw	4
70	#6x38L	Taper Pins	2	94	M10x30	Screw	4
71	1/2"1CL	OIL Plug	2	95	M4XP0.7	Nut	3
72	M12	Hook Ring	2	96	M10xP1.25	Nut	1
97	M12xP1.5	Nut	1				

8. Pneumatic System

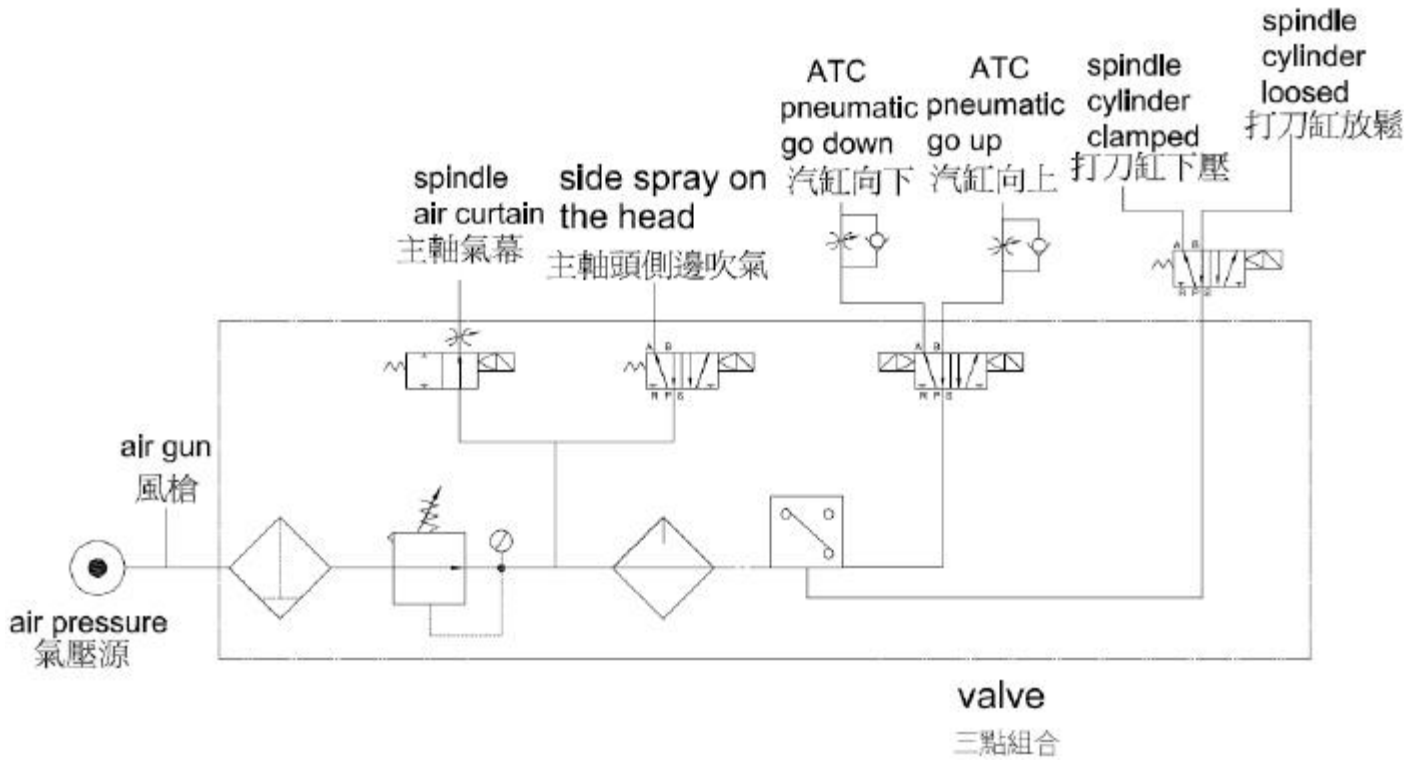

Air Unit Layout

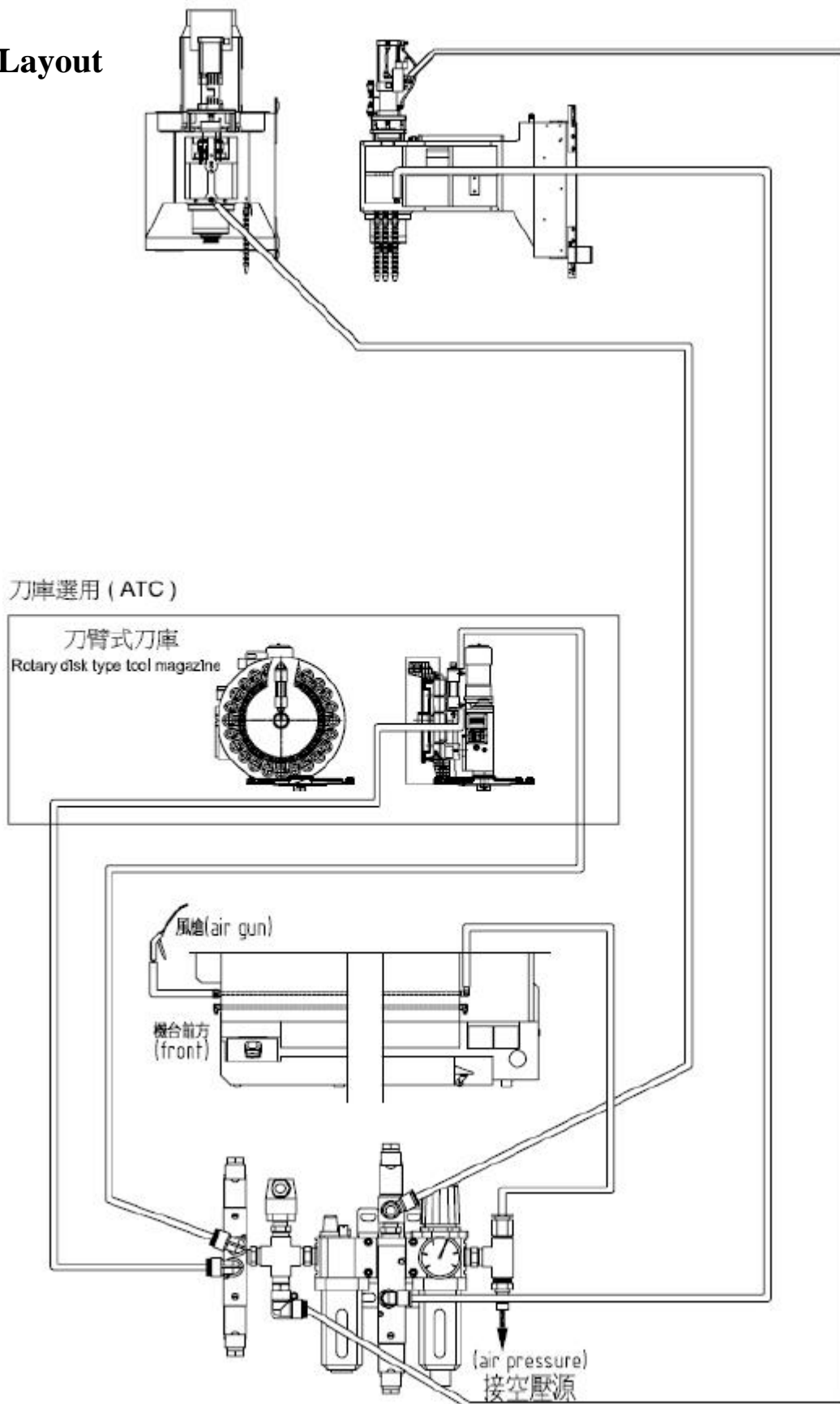

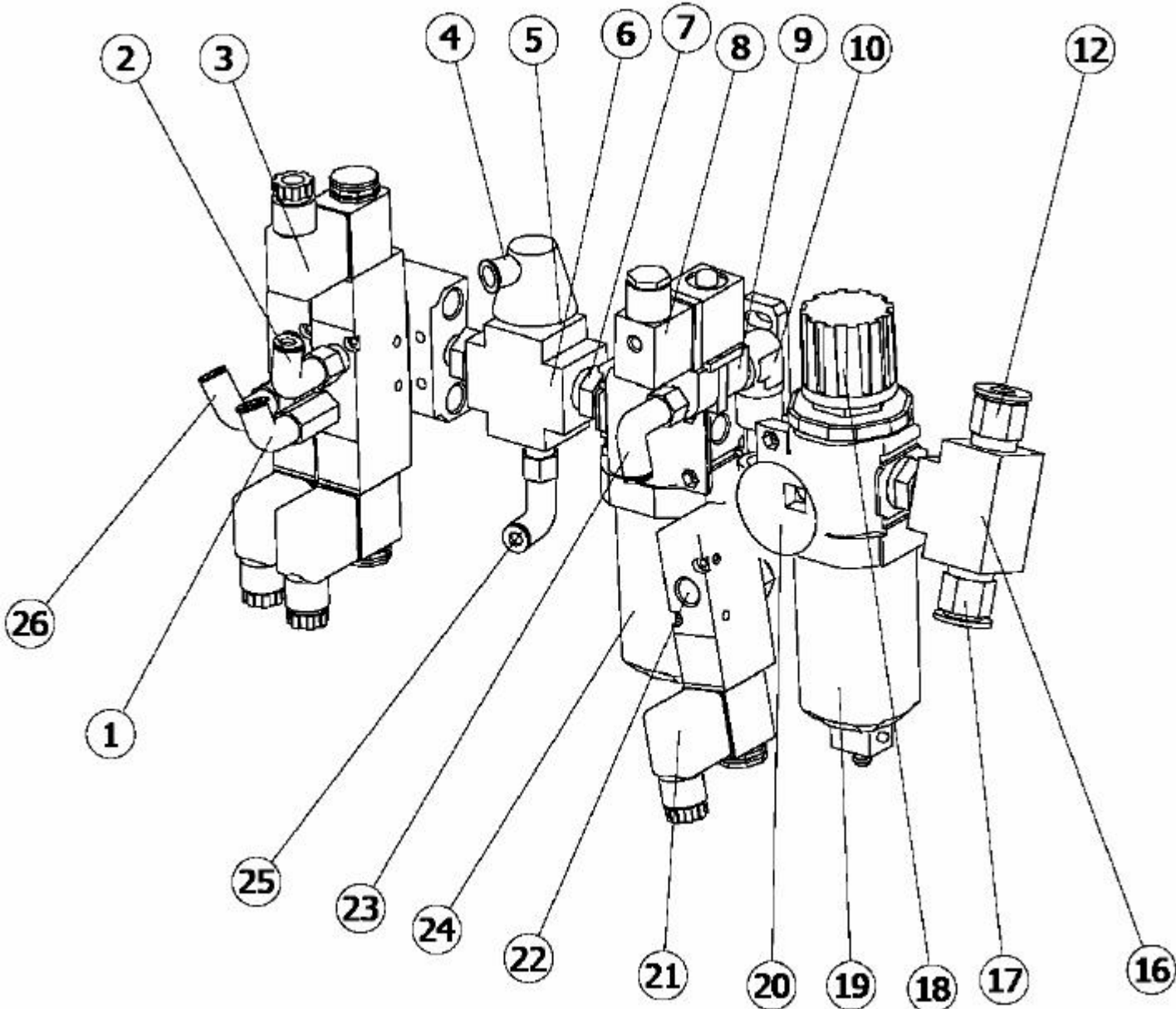

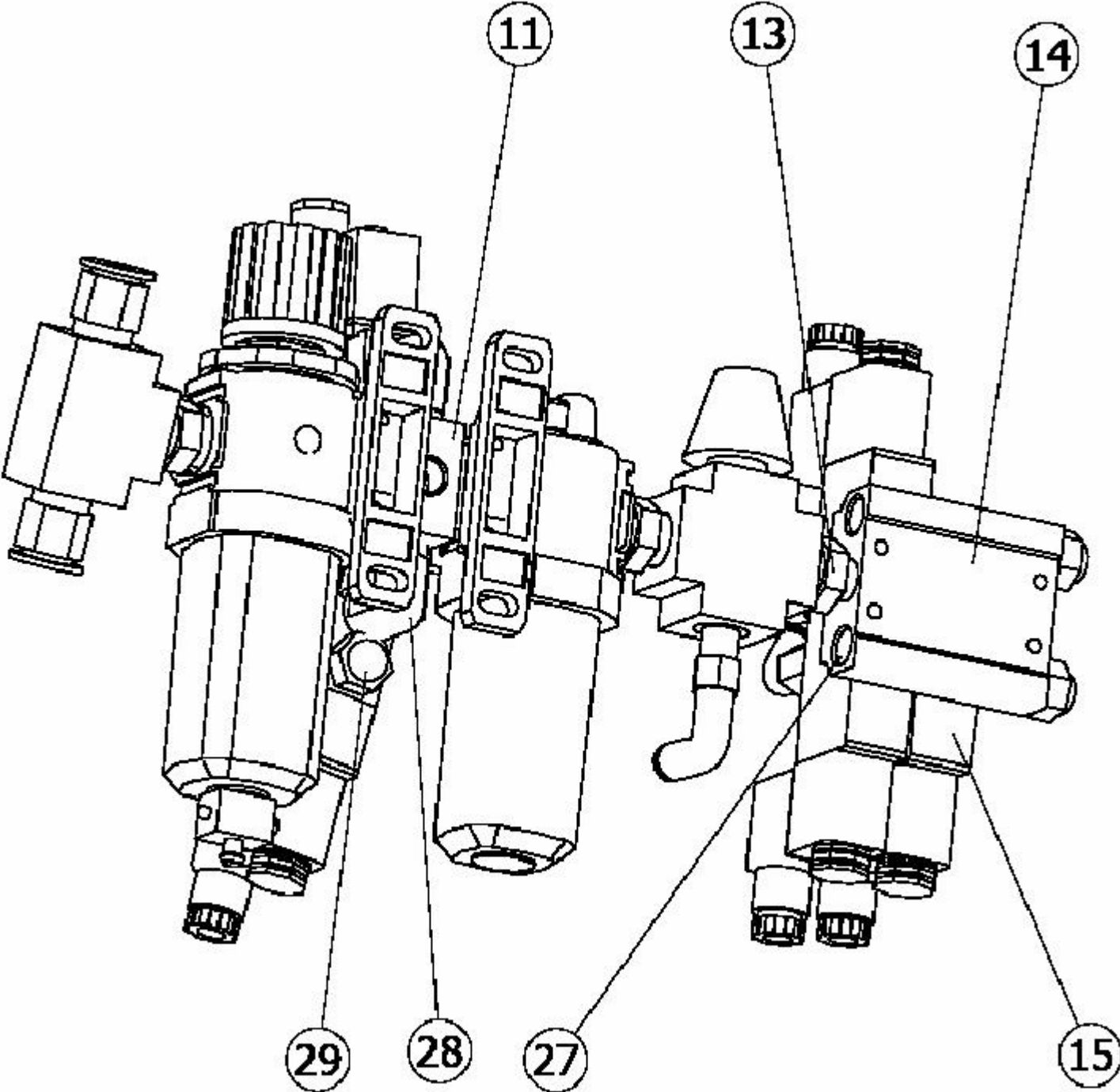

Item	Name	Size	Qty.
1	Elbow Quick Coupling	Ø10mm_1/4"	1
2	Elbow Quick Coupling	Ø10mm_1/4"	1
3	Solenoid	1/4" 五口二位_雙電控	1
4	Air Pressure Switch	1/4"	1
5	Reducing Bush	1/4"x3/8"	3
6	Cross Joint	3/8"	1
7	Hex. Double Joint	3/8"	1
8	Solenoid	1/4" 二位二通	1
9	Hex. Double Joint	1/4"	1
10	Elbow Hex. Double Joint	1/4"	2
11	Adapter	MACP300 T10	1
12	Straight Quick Coupling	Ø10mm_3/8"	1
13	Straight Coupling	1/4"T*3/8"T	1
14	Control Valve Seat	1/4"*2 聯	1
15	Solenoid	MUSC-220-4E1-DC24 附燈	1
16	T-Joint	3/8"	1
17	Quick Coupling	Ø12mm_3/8"	1
18	Pressure Control Valve	MACP300-12A	1
19	Filter Regular Unit	MACP300-12A	1
20	Pressure Display	1.5" 10KG/PSI	1
21	Solenoid	3/8" 三口二位_單電控	1
22	Elbow Quick Coupling	Ø8mm_3/8"	1
23	Speed Control Joint	Ø8mm_1/4"	1
24	Lubricator Regular Unit Seat	55cc MACP300-12A	1
25	Elbow Quick Coupling	Ø10mm_3/8"	1
26	Quick Coupling	Ø10mm_1/4"*90 度	1
27	Hex. Socket plug	1/4"	4
28	Elbow Hex. Double Joint	3/8"	1
29	Silencer	1/4"	3

Chapter 8 APPENDIX

1. Replacing fuse on control unit

WARNING

Before replacing a blown fuse, locate and remove the cause of the blown fuse.

For this reason, only those personnel who have received approved safety and maintenance training may perform this replacement work.

When opening the cabinet and replacing a fuse, be careful not to touch the high-voltage circuits (marked  and fitted with an insulating cover).

Touching the uncovered high-voltage circuits presents an extremely dangerous electric shock hazard.

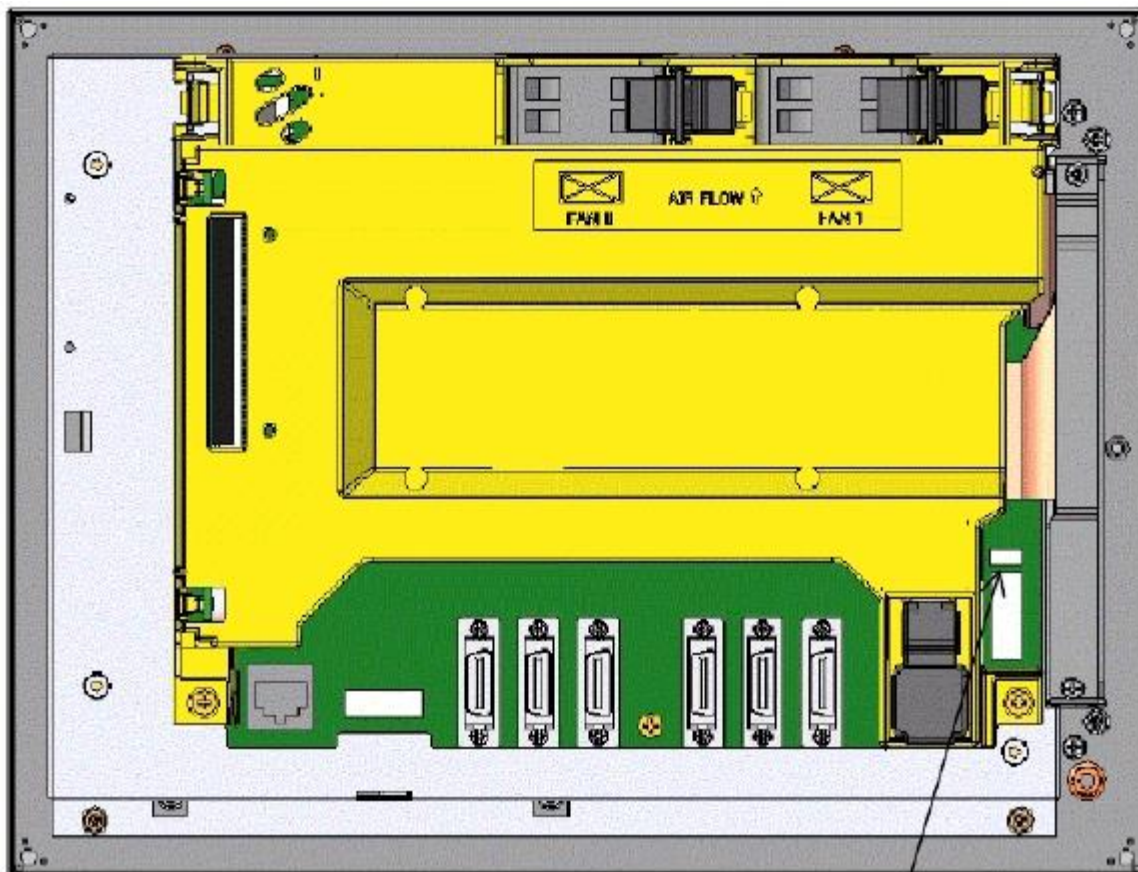

FUSE1 (transparent)
for 24 VDC input

2. Replacing battery

Offset data, and system parameters are stored in SRAM in the control unit. The power to the SRAM is backed up by a lithium battery mounted on the front panel of the control unit. The above data is not lost even when the main battery goes dead. The backup battery is mounted on the control unit at shipping. This battery can maintain the contents of memory for about a year.

When the voltage of the battery becomes low, alarm message "BAT" blinks on the display and the battery alarm signal is output to the PMC. When this alarm is displayed, replace the battery as soon as possible. In general, the battery can be replaced within two or three weeks, however, this depends on the system configuration.

If the voltage of the battery becomes any lower, memory can no longer be backed up. Turning on the power to the control unit in this state causes system alarm to occur because the contents of memory are lost. Clear the entire memory and reenter data after replacing the battery.

FANUC thus recommends that the battery be replaced periodically, once a year, regardless of whether a battery alarm is issued.

The following two kinds of batteries can be used.

- Lithium battery built into the CNC control unit.
- Two alkaline dry cells (size D) in the external battery case.

NOTE

A lithium battery is installed as standard at the factory.

2.1 When a lithium battery is used**- Replacement procedure**

Prepare a new battery unit (ordering code: A02B-0309-K102).

- (1) Turn on the power to the CNC. After about 30 seconds, turn off the power.
- (2) Extract the old battery unit from the lower right of the rear of the CNC unit. (Hold the latch of the battery unit, and extract the unit upward while releasing the claw from the case.)

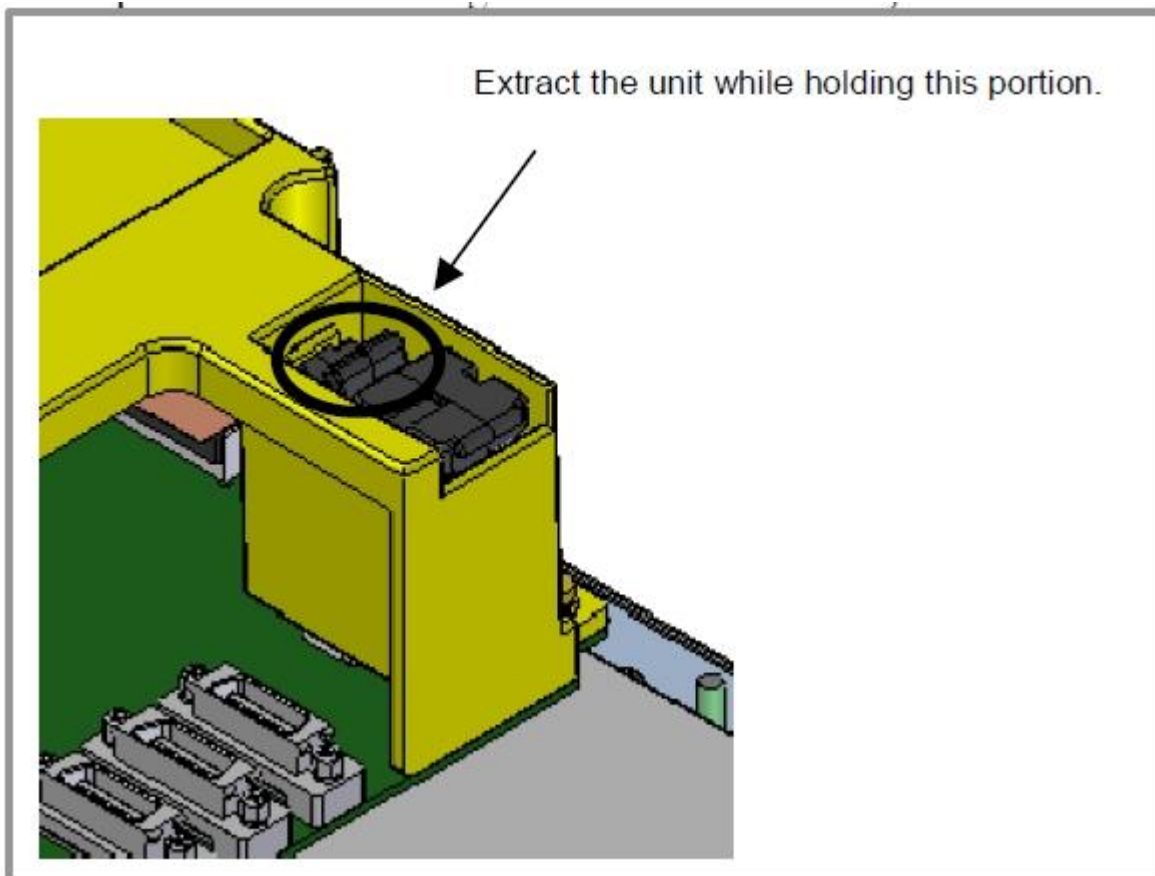

- (3) Mount the new battery unit. (Push the battery unit in until the claw is latched into the case.) Ensure that the latch is engaged securely.

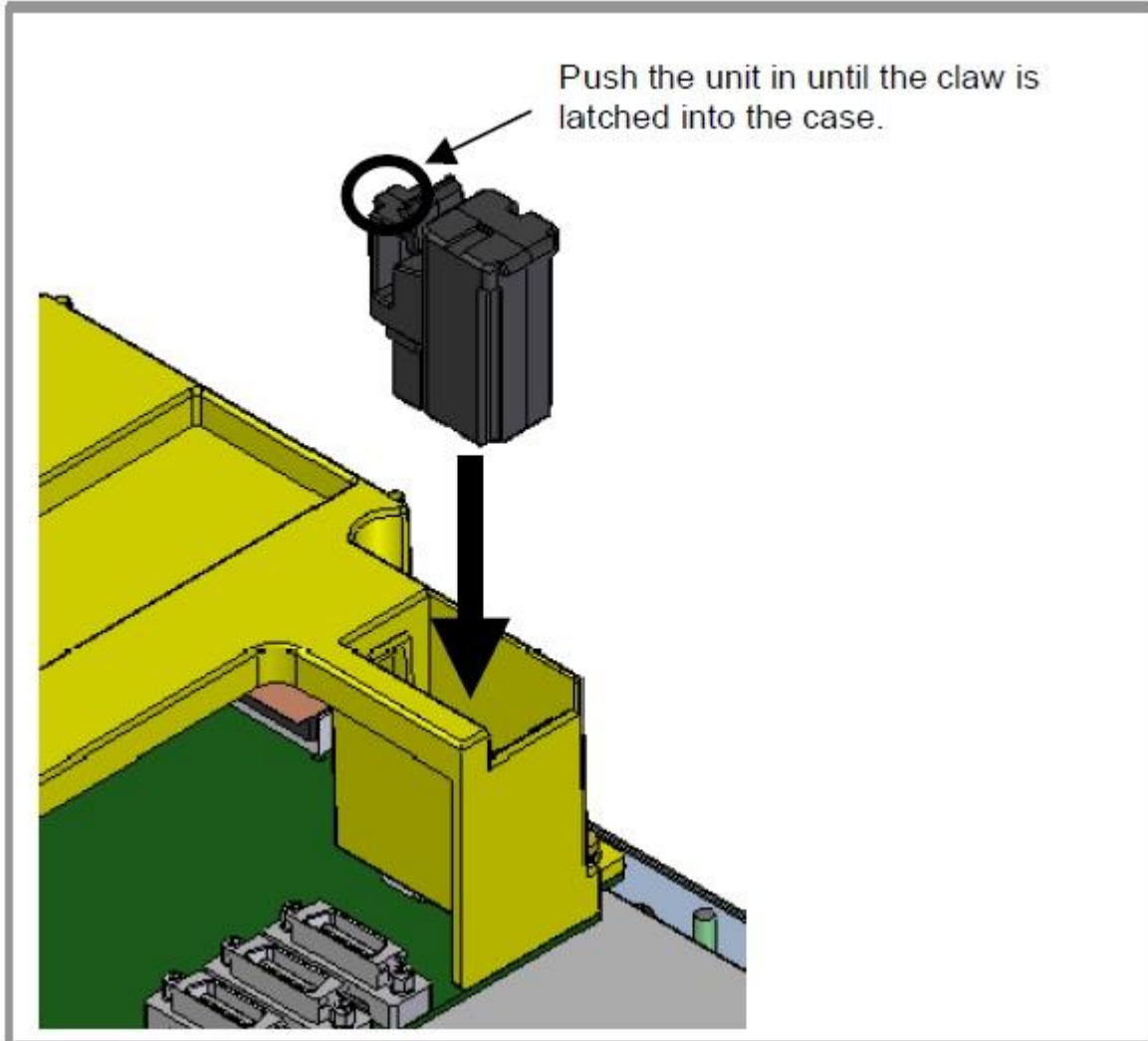

⚠ WARNING

Using other than the recommended battery may result in the battery exploding. Replace the battery only with the specified battery (A02B-0309-K102).

⚠ CAUTION

Steps 1 to 3 should be completed within 30 minutes. Do not leave the control unit without a battery for any longer than the specified period. Otherwise, the contents of memory may be lost. If steps 1 to 3 may not be completed within 30 minutes, save all contents of the SRAM memory to the memory card beforehand. Thus, if the contents of the SRAM memory are lost, the contents can be restored easily. See Chapter 3 or Appendix C for explanations about how to save the contents of the SRAM memory.

When discarding a battery, observe the applicable ordinances or other rules of your local government. In addition, cover the exposed pins with tape or other insulation materials to prevent a short circuit before discarding the battery.

2.2 When alkaline dry cells (size D) are used

- Replacing the battery

- (1) Prepare two new alkaline dry cells (size D).
- (2) Turn on the power of the control unit.
- (3) Remove the battery case cover.
- (5) Replace the batteries, paying careful attention to their orientation.
- (6) Replace the battery case cover.

⚠ CAUTION

To replace the battery when the power is off, follow the same procedure as that for the replacement of a lithium battery, described above.

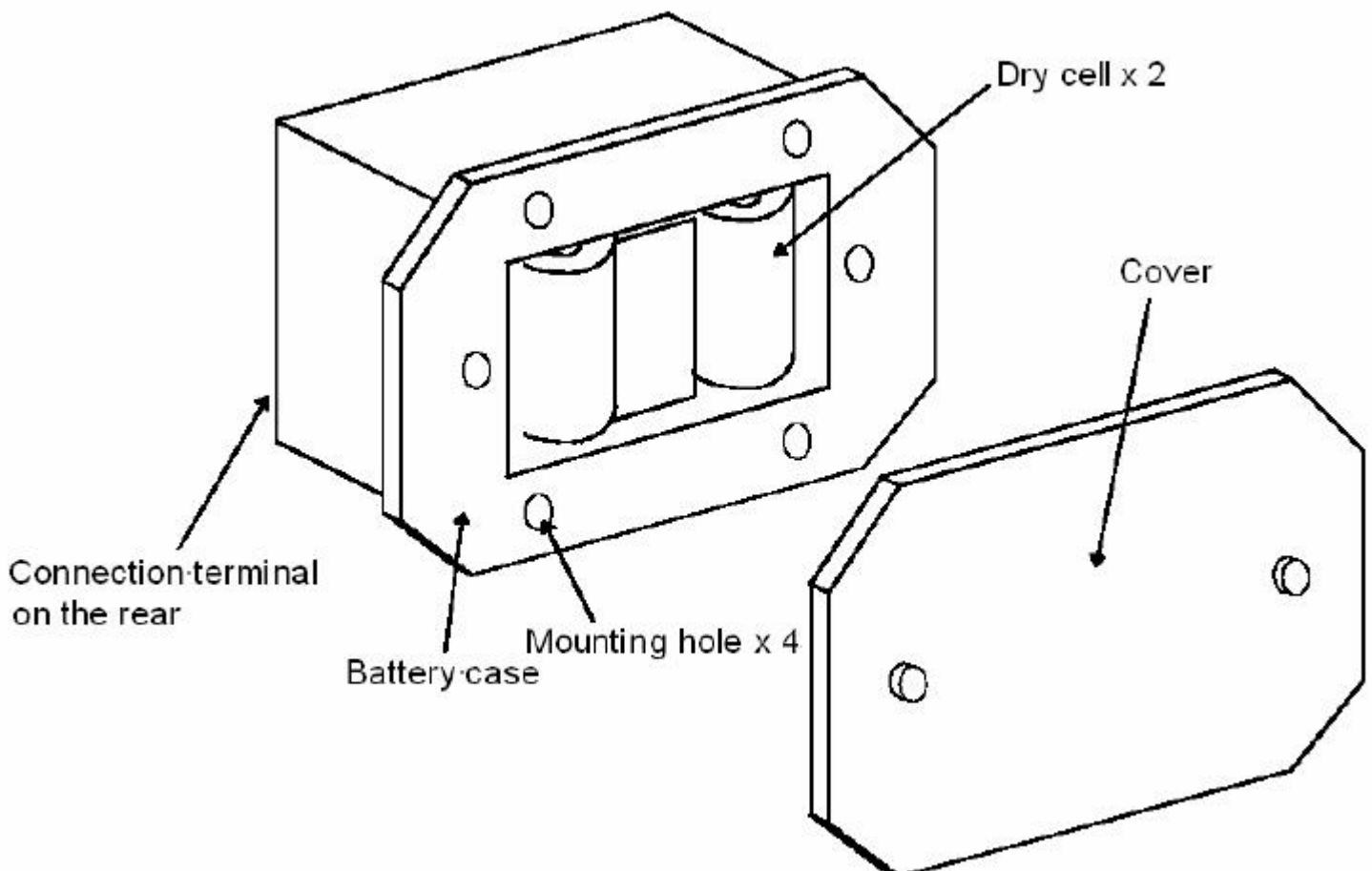

2.3 Battery for separate absolute pulse coders (6VDC)

The current position data of the absolute pulse coder connected to the separate detector interface unit is saved by the battery connected to connector JA4A of the separate detector interface unit.

If the voltage of the battery drops, DS alarms 306 to 308 are issued. When DS alarm 307 (battery voltage drop alarm) occurs, replace the battery as soon as possible. Estimated time to run out of the battery is 1 to 2 weeks, but the actual life depends on the number of pulse coders.

If the voltage of the battery further drops, DS alarm 306 (battery zero alarm) occurs. In this case, the current position of the pulse coder cannot be recorded and DS alarm 300 (reference position return alarm) occurs. Replace the battery and perform a reference position return.

Although the battery life depends on the number of pulse coders connected, it is recommended that the battery be replaced annually regardless of the issuance of the above alarms.

Replacing a battery

Obtain four commercially available alkaline batteries (size D).

- <1> Turn on the power of the machine (CNC).
- <2> Loosen the screws of the battery case, and remove the cover.
- <3> Replace the dry batteries in the case.

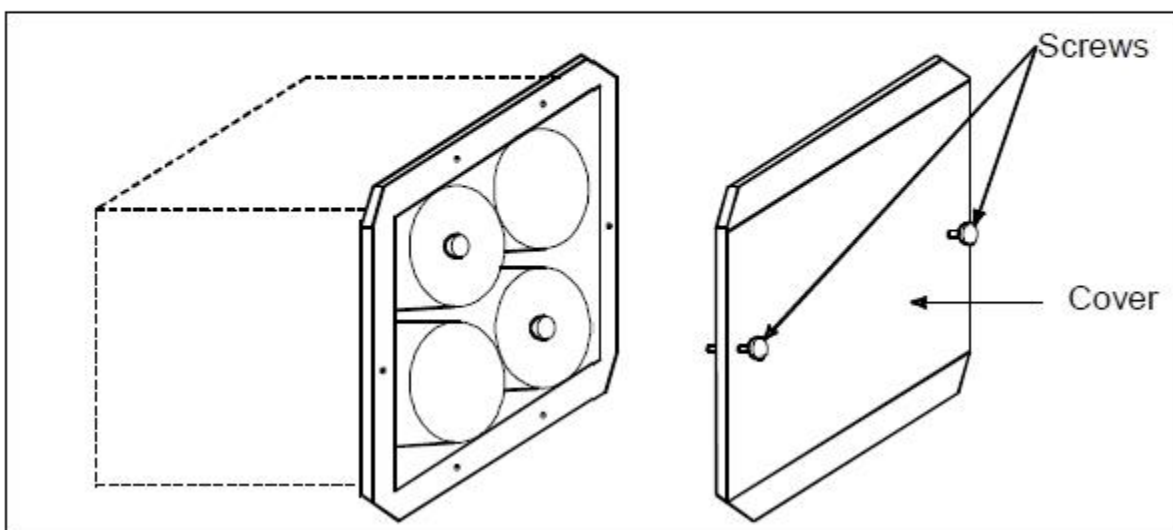

- <4> After installing the new batteries, replace the cover.
<5> Turn off the power to the machine (CNC).

⚠ WARNING

When connecting the battery, pay attention to its polarity. Connecting it in reverse polarity may lead to abnormal heat generation, explosion, or even fire. It may also lead to loss of absolute position data from the absolute pulse coder. Never use batteries other than the specified type (Size D alkaline batteries).

⚠ CAUTION

The battery must be replaced with the power of the CNC turned on (the servo amplifier turned on). Note that, if batteries are replaced while no power is supplied to the CNC, the recorded absolute position is lost.

2.4 Battery for absolute pulse coders Built into the built Motor (6VDC)

The battery for the absolute pulse coder built into the motor is installed in the servo amplifier. For the methods of connection and replacement, refer to the maintenance manual of your servo amplifier.

3. Replacing fan unit

⚠ WARNING

When opening the cabinet and replacing a fan motor, be careful not to touch the high-voltage circuits (marked  and fitted with an insulating cover).

Touching the uncovered high-voltage circuits presents an extremely dangerous electric shock hazard.

3.1 Replacement procedure

- <1> Before replacing a fan motor, turn off the power to the CNC.
- <2> Extract the fan motor to be replaced. (Hold the latch of the fan unit, and extract the unit upward while releasing the claw from the case.)

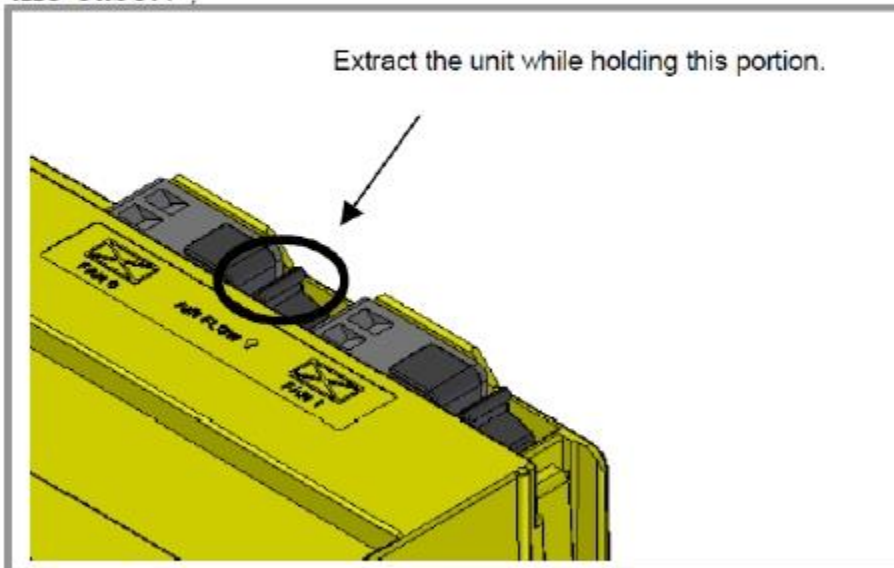

- <3> Mount a new fan unit. (Push the fan unit in until the claw is latched into the case.)

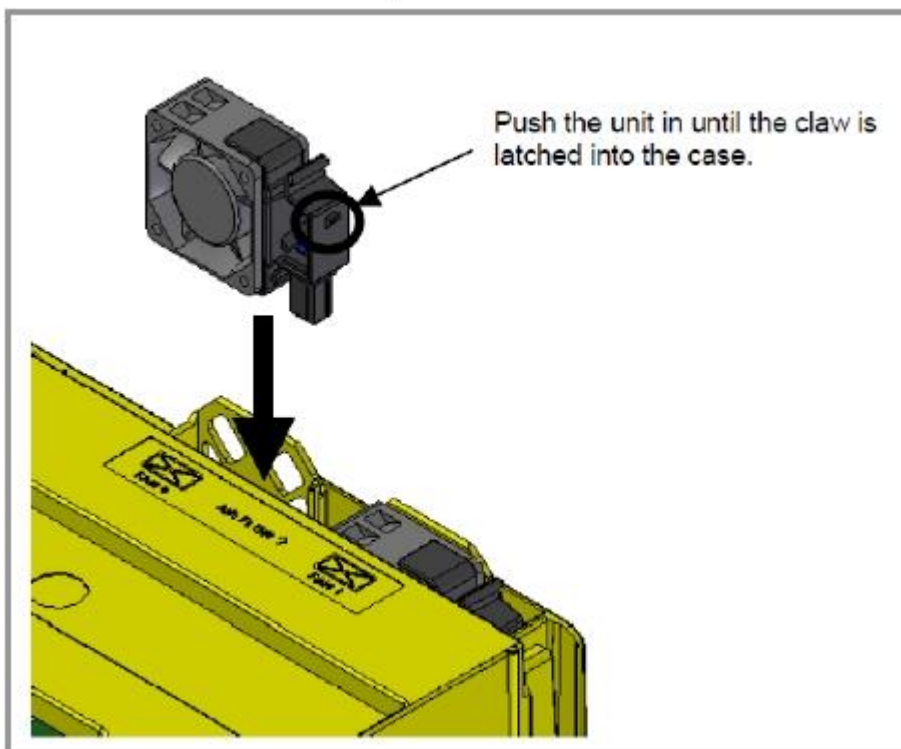

4. High Speed High Accuracy Machining Control Function

This function is applied major in machining with high speed and high accuracy. It can reduce delay of acceleration/deceleration due to promotion of federate so that the error of shape in machining is reduced too.

Besides, with the function of the most blocks looked-ahead in linear acceleration/deceleration before interpolation, smooth acceleration/deceleration over multi-blocks is achieved. Therefore, the machining effect is improved.

4.1 AI Advanced Preview Control (AI-APC)

Format :

G05.1 Q_ :

Explanations :

Q1 : AI advanced preview control ON

Q0 : AI advanced preview control OFF

The following functions become effective in the AI-APC mode.

1. Multiple blocks look – ahead bell-shaped acceleration / deceleration function before interpolation (Maximum 30 block).
2. Linear acceleration / deceleration after interpolation.
3. Automatic corner deceleration function.
4. Feed rate clamp based on are radius function.
5. Block overlap function (Maximum 5 blocks).
6. Look-ahead feed forward function.

Note : (1) Please command G05.1 with an independent block.

(2) AI-APC is released by the RESET key .

(3) It's necessary to turn off AI-APC mode before tool change then turn on AI-APC mode.

EX : O2233 ;

:

G05.1 Q1 ;

:

G05.1 Q0 ;

M6T_ ;

M30 ;

4.2 AI NANO Contour Control (AI NANO CC)

Format :

G05.1 Q_ :

Explanations :

Q1 : AI NANO contour control ON

Q0 : AI NANO contour control OFF

The following functions become effective in the AI NANO CC mode.

1. Multiple blocks look – ahead bell-shaped acceleration / deceleration function before interpolation.
2. Linear acceleration / deceleration after interpolation.
3. Automatic corner deceleration function.
4. Feed rate clamp based on arc radius function.
5. Block overlap function (Maximum 5 blocks).
6. Look-ahead feed forward function.

7. NANO interpolation function

Note : (1) Please command G05.1 with an independent block.

(2) AI NANO CC is released by the RESET key  .

(3) It's necessary to turn off AI NANO CC mode before tool change then turn on AI NANO CC mode.

EX : O2233 ;

:

G05.1 Q1 ;

:

G05.1 Q0 ;

M6T_ ;

M30 ;

4.3 AI NANO High Precision Contour Control (AI NANO HPCC) (Optional Function)

Format :

G05.1 P_ :

Explanations :

P10000 : AI NANO high precision contour control ON

Q0 : AI NANO high precision contour control OFF

The following functions become effective in the AI NANO HPCC mode.

1. Multiple blocks look – ahead bell-shaped acceleration / deceleration function before interpolation. (Maximum 600 blocks)
2. Linear acceleration / deceleration after interpolation.
3. Automatic corner deceleration function.

4. Feed rate clamp based on arc radius function.
5. Block overlap function (Maximum 5 blocks).
6. Look-ahead feed forward function.
7. Smooth interpolation function
8. NANO interpolation function

Note : (1) Please command G05 with an independent block.

(2) AI NANO HPCC is released by the RESET key  .

(3) It's necessary to turn off AI NANO HPCC mode before tool change then turn on AI NANO HPCC mode.

EX : O2233 ;

:

G05 P10000 ;

:

G05 P0 ;

M6T_ ;

M30 ;

4.4 Conditions for High Speed High Accuracy Control

When the function of high speed high accuracy is commanded , the alarm No.5111 will occur if
The following conditions are not satisfied.

G code	Meaning
G00	Positioning
G01	Linear Interpolation
G02	Circular Interpolation / Helical Interpolation (CW).
G03	Circular Interpolation / Helical Interpolation (CCW).
G13.1	Polar coordinate interpolation cancel mode
G15	Polar coordinate command cancel
G25	Spindle speed fluctuation detection off
G40	Cutter compensation cancel
G40.1	Normal direction control cancel mode
G49	Tool length compensation cancel
G50	Scaling cancel
G50.1	Programmable mirror image cancel
G64	Cutting mode
G67	Macro modal call cancel
G69	Coordinate system rotation cancel
G80	Canned cycle cancel
G94	Feed per minute
G97	Constant surface speed control cancel
G160	Infeed control function cancel

4.5 Alarm Message

No.	Message	Contents
5000	ILLEGAL COMMAND CODE	The specified code was incorrect in the high-precision contour control (HPCC) mode.
5003	ILLEGAL PARAMETER (HPCC)	The parameter setting is incorrect.
5009	PARAMETER ZERO (DRY RUN)	The maximum feedrate (par. No. 1422) or the feedrate in dry run (par. No. 1410) is 0 in the HPCC model.
5012	G05 P10000 ILLEGAL START UP(HPCC)	G05 P10000 has been specified in a mode from which HPCC mode cannot be entered. (par. No. 8403#1)
5110	IMPROPER G-CODE (G05.1 Q1 MODE)	An illegal G code was specified in simple high-precision contour control mode. A command was specified for the index table indexing axis in simple high-precision contour control mode.
5111	IMPROPER MODAL G-CODE (G05.1 Q1)	An illegal G code is left modal when simple high-precision contour control mode was specified.
5112	G08 CAN NOT BE COMMANDED	Look-ahead control (G08) was specified in simple high-precision contour control mode.
5114	NOT STOP POSITION (G05.1 Q1)	At the time of restart after manual intervention, the coordinates at which the manual intervention occurred have not been restored.

4.6 NURBS Function (Optional Function)

4.6.1 Features and Advantages

NURBS is the abbreviation of Non Uniform Rotational B – Spine .It is a type of free-form curve (free-form curved surfaces) representation. It is often applied in mold design recently. (NURBS is supported by IGES , Initial Graphics Data Exchange Specification).

1. Features :

- 1). Smooth over the entire length (continuous liner and quadratic differentiation)
- 2). NURBS can represent quadratic curves (such as a circle , ellipse , parabola and hyperbola) that can not be represented with Bezier curves.
- 3). It is a solution for problems of NC program used in mold cutting and achieves NURBS interpolation in mode of high speed high accuracy for mold cutting.

2. Advantages of using the NURBS commands :

- 1). Reduce the volume of memory occupied by the program.
Because of fewer control points in NURBS interpolation, the volume of memory occupied by the program is reduced.
- 2). High speed is not necessary for program transfer.
Because memory of program is reduced , it is possible to do cutting in mode of high speed high accuracy without high speed of program transfer .

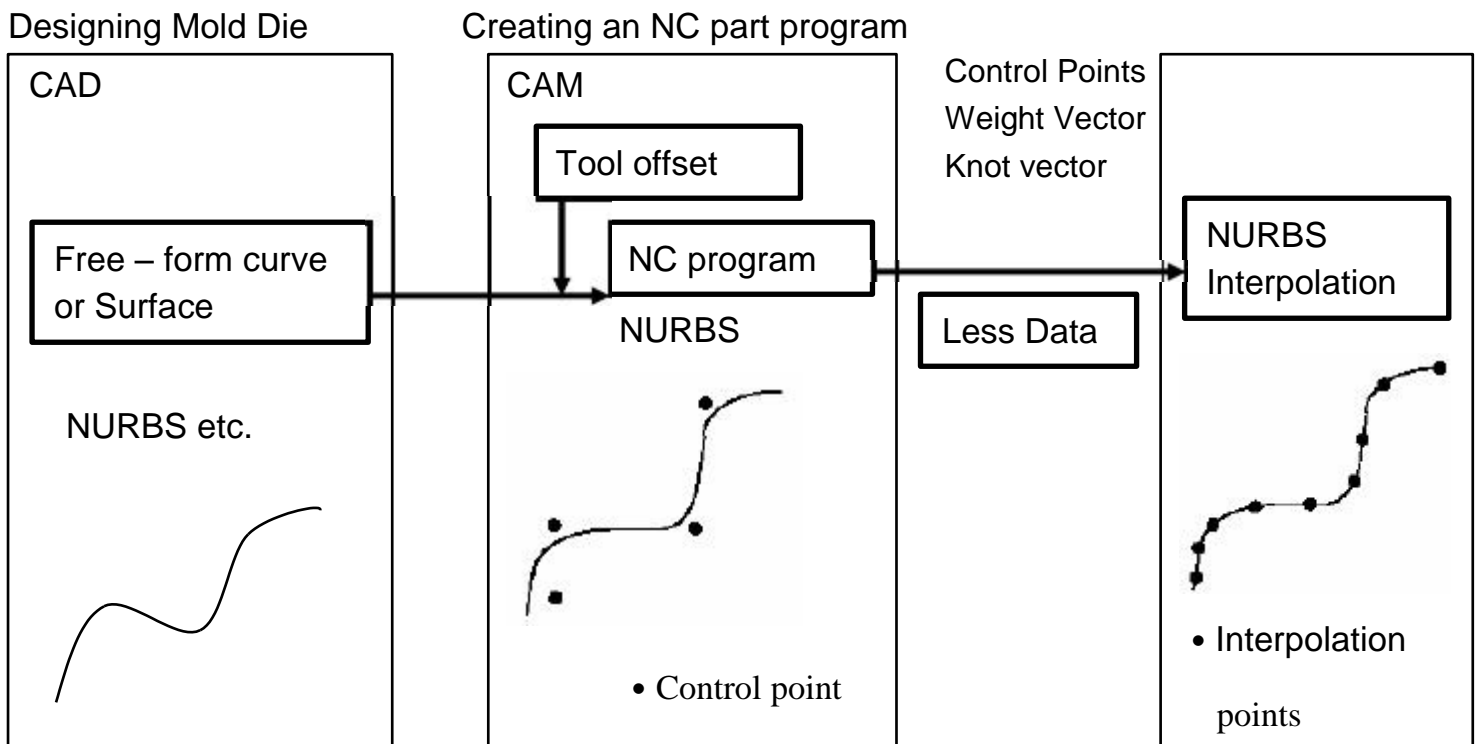

4.6.2 Definition

Definition of variables :

k : Rank

Pi : Control point

wi : Weight

Xi : Knot (Xi ≤ Xi + 1)

Knot vector [X0 , X1 , ... , Xm] (m = n + k)

t : Spline parameter

The major function N of the B curve can be expressed with Boor-Cox as follows :

$$N_{i, 1}(t) = \begin{cases} 1 & (X_i \leq t \leq X_{i+1}) \\ 0 & (t < X_i, X_{i+1} < t) \end{cases}$$

$$N_{i, 1}(t) = \frac{(t - X_i) N_{i, k-1}(t)}{X_{i+k-1} - X_i} + \frac{(X_{i+k} - t) N_{i+1, k-1}(t)}{X_{i+k} - X_{i+1}}$$

NURBS curve P(t) is expressed as follows :

$$p(t) = \frac{\sum_{i=0}^n N_{i, k}(t) w_i p_i}{\sum_{i=0}^n N_{i, k}(t) w_i} \quad (X_0 \leq t \leq X_m)$$

Note : (1) When the signal of MANUAL ABSOLUTE is ON and manual operation is interrupted, an alarm message will occur.

(2) The tool diameter offset is not available in the NURBS interpolation. Thus, the tool diameter offset has to be cancelled before starting the NURBS interpolation.

(3) When the RESET key  is pressed during the NURBS interpolation being executed, the G code of group 01 will become the preset value.

Parameter

No.	Meaning
3402 # 0	Mode entered when the power is turned on or when the control is cleared 0 : G00 mode (positioning) 1 : G01 mode (linear interpolation)

Alarm

No.	Displayed message	Meaning
PS 5115	SPL : ERROR	Number of rank is out of the range.
		Knot is not assigned.
		Illegal knot is assigned.
		Number of axis is out of the range.
		Other error of program.
PS 5116	SPL : ERROR	Format error.
		Knot is not increased progressively.
		Mode error
PS 5117	SPL : ERROR	The first NURBS control point is illegal.
PS 5118	SPL : ERROR	Manual operation is interrupted when the signal of Manual Absolute is ON.

4.6.3 Format

The NURBS interpolation must be applied in the mode of AI NANO High Precision Contour Control (AI NANO HPCC)

Format :

G05 P10000 ;  AI NANO HPCC Control ON

:

G06.2 [P] K _ X _ Y _ Z [R] [F] ;

K _ X _ Y _ Z [R] ;

K _ X _ Y _ Z [R] ;

:

K _ X _ Y _ Z [R] ;

K _ ;

:

K _ ;

G01.....

:

G05 P10000 ;  AI NANO HPCC Control OFF

Description of commands

G06.2 : NURBS Interpolation ON

P_ : Rank of NURBS curve

X_ Y_ Z_ : Control point

R_ : Weight

K_ : Knot

F_ : Feed rate

4.6.4 Notation

1. G06.2 is a modal G code of group 01. So, it cannot be used together with other G codes such as G01, G02 in the same block.
2. The NURBS interpolation mode is selected when G06.2 is programmed in AI NANO HPCC mode.
3. The valid data range for P is 2 to 4. The meaning of P values is as follows :
 - P2 : NURBS has a rank of two (degree of one).
 - P3 : NURBS has a rank of three (degree of two).
 - P4 : NURBS has a rank of four (degree of three).
4. In the NURBS interpolation mode, any command other than the NURBS interpolation command (miscellaneous function and others) can not be specified.

NURBS applies variables of control points (X__Y__Z__), weight (R) and Knot vector (K) to express a free-form curve.

Control point : The coordinated points to determine the shape of a curve. The curve is not necessary to pass the control point.

Weight : Each control point keeps a weight which property is similar to the attracting force. The larger the weight is, the curve is closer to the control point.

Knot vector : Specify the values of the number series for the parameter t in the NURBS function. If the increasing rate is small, the increasing rate in the function becomes small. Example : The situation of swift current in water flow.

5. Rotary table Interface Install Description

5.1 Interface detail

Item	Name		Qty
1	Rotary table side	Motor power wire	2
		4 th clamp/unclamp switch wire	
		4 th clamp/unclamp solenoid valve wire	
2		Motor encoder wire	2
3	Machine side	Motor encoder wire	2
4		Motor power wire	2
5		4 th clamp/unclamp switch wire	2
6		4 th clamp/unclamp solenoid valve wire	2
7		waterproof cover for item 4	2
8		waterproof cover for item 3	2

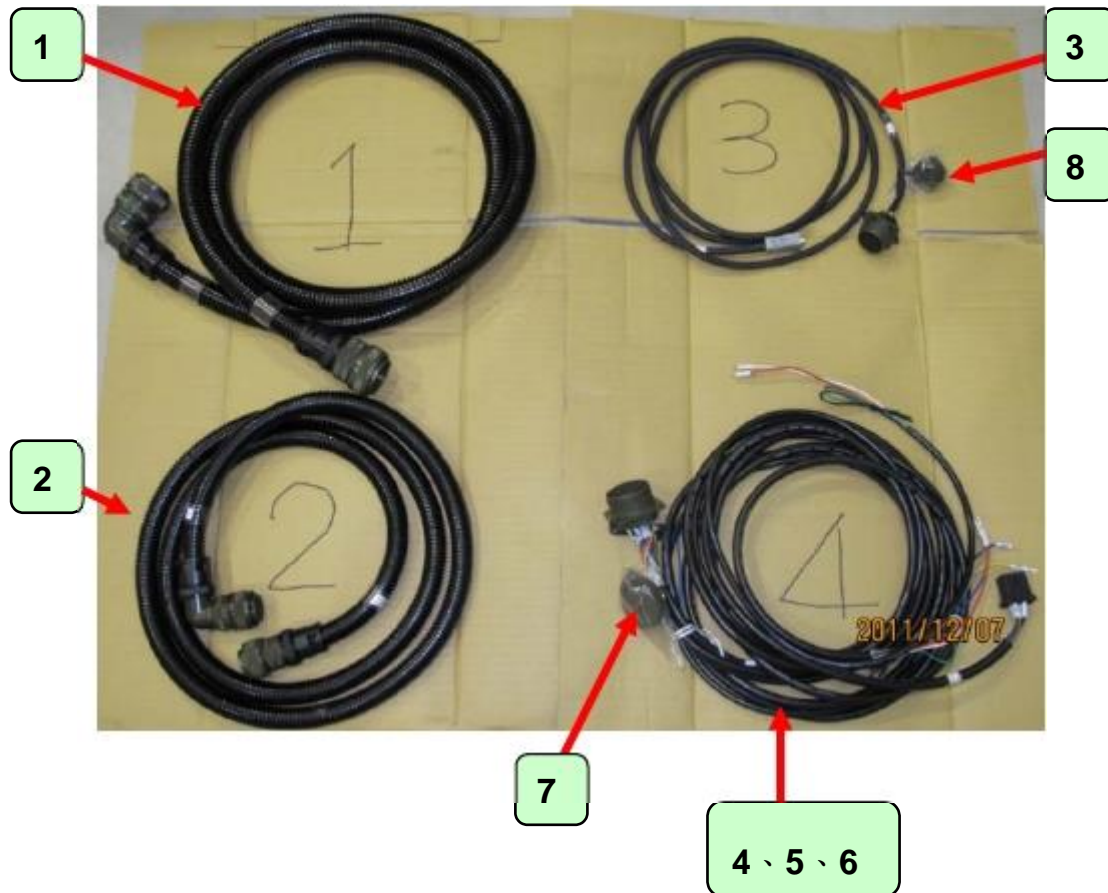

5.2 Parts description

1) Motor power wire
(Rotary table side)



2) Motor encoder wire
(Rotary table side)



3) Motor encoder wire
(Rotary table side)



4 、 5 、 6) Motor power wire
(Machine side)



7) waterproof cover
for item 4



8) waterproof cover
for item 3



5.3 Terminal block input side wires description

Item	Name	Wire number	Remark
1	4 th motor power	AU.AV.AW.PE	
2	DC24V	24V	For clamp/unclamp switch power
3	Clamp switch	185	
4	Unclamp switch	186	
5	Z axis zrn switch	193	
6	4 th clamp/unclamp solenoid valve	277	★Solenoid valve power is DC24V pls double check it

1) DC24V

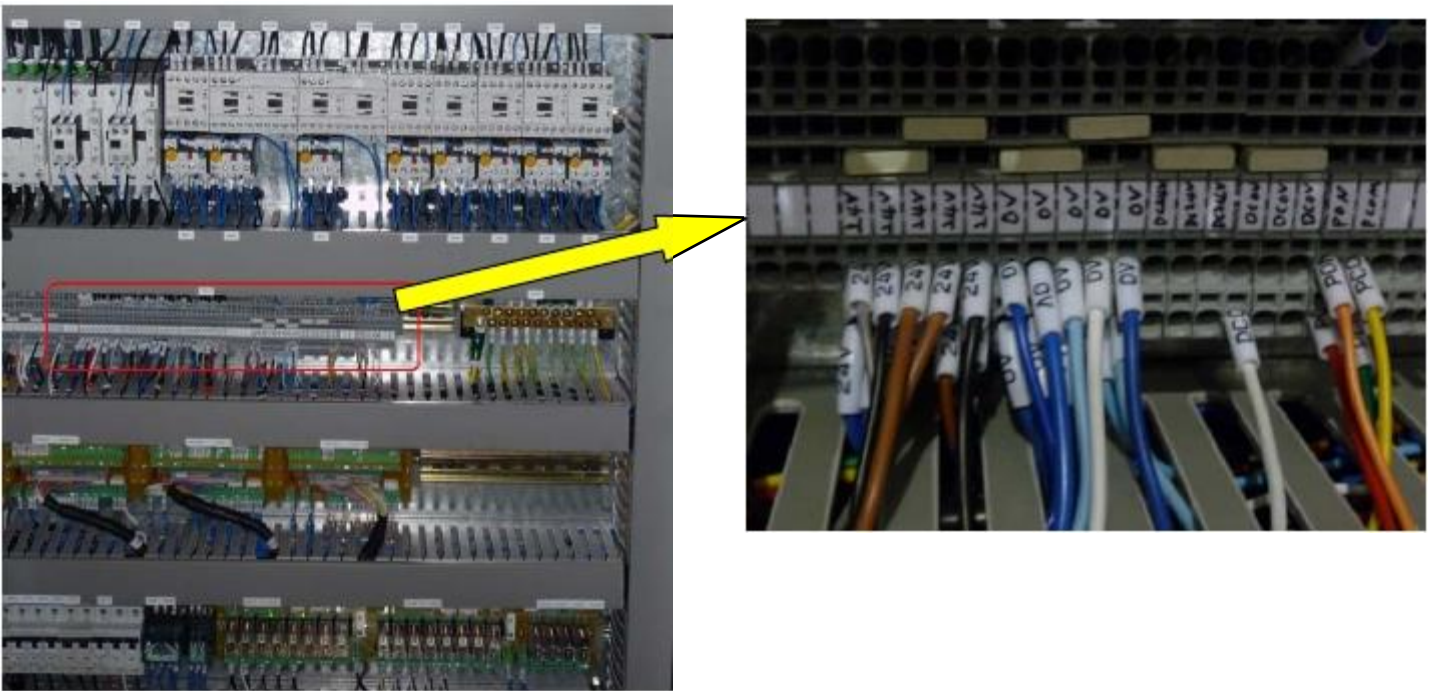

5.4 PLC description :

1) M CODE :

M25 : A Axis Unclamp M26 : A Axis Clamp

2) A Axis Clamp / Unclamp Detect :

Clamp Detect : X8.5 Unclamp Detect : X8.6

3) Clamp/unclamp solenoid valve power : Y7.7

4) Alarm message Description :

AL1084 : A AXIS UNCLAMP FINISH ERROR

AL1085 : A AXIS CLAMP FINISH ERROR

5) Unclamp delay time :

Timer NO.80 , setting value : 496

6) Alarm Detect Timer :

Timer NO.81 , setting value : 2000 → Unclamp

Timer NO.82 , setting value : 2000 → clamp

6. Tool Setter Probe Install



1. Hardware assembly description
Tool touch direction

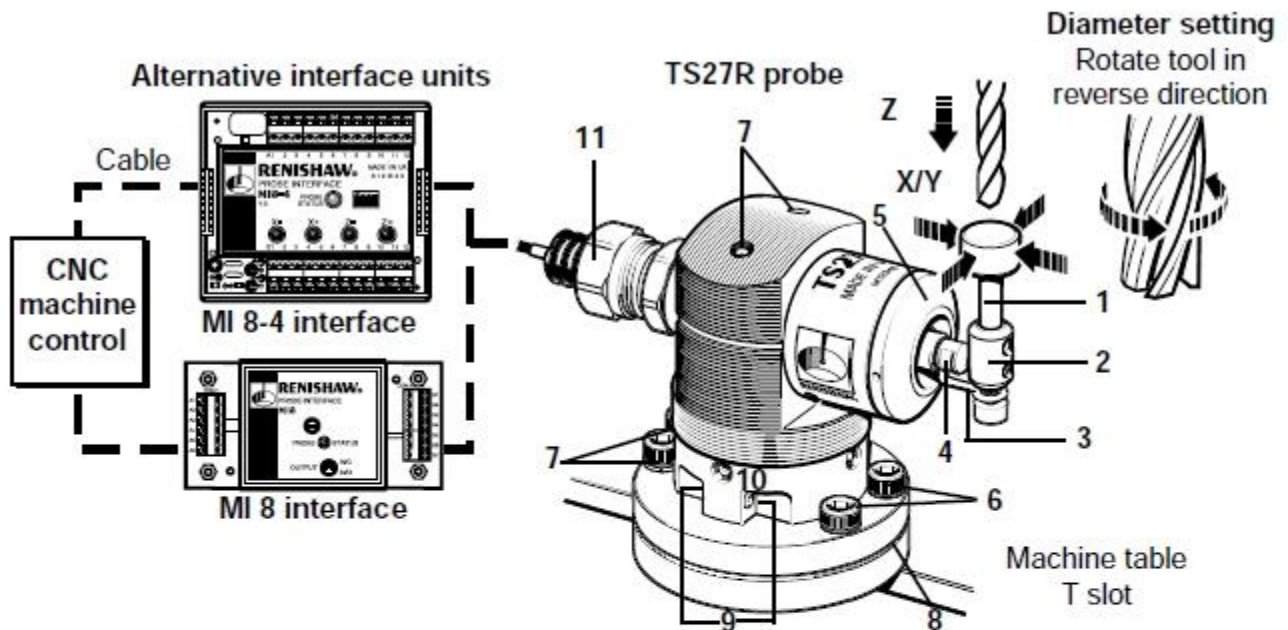

The TS27R probe is used for tool setting on CNC machining centres.

For tool length measurements and broken tool detection, the tool is driven against the probe's stylus in the Z axis. Rotating tools can be set in X and Y axes for tool radius offsets.

Screw adjusters allow the stylus to be aligned with the machine's axes.

An interface unit processes signals between the probe and the CNC control.

1. Stylus
2. Stylus holder for disc or square styli
3. Captive link
4. Break stem
5. Front cover
6. Probe's base holding screws
7. Stylus level alignment – adjusting screws
8. Plinth
9. Square stylus axes alignment – adjusting screws
10. Square stylus axes alignment – locking screws
11. Conduit adaptor

2. hardware specification description

Achievable set-up tolerances

The tolerances to which tools can be set depend upon the flatness and parallelism of the stylus tip setting. A value of 5 μm (0.0002 in) front to back and side to side is easily achievable over the flat portion of the stylus tip, and 5 μm (0.0002 in) parallelism is easily achievable with the axes of a square tip stylus. This setting accuracy is sufficient for the majority of tool setting applications.

Recommended rotating tool feed rates

Cutters should be rotated in reverse to the cutting direction.

First touch – machine spindle rev/min

Rev/min for the first move against the probe stylus is calculated from a surface cutting speed of 60 m/min (197 ft/min).

Spindle speed should be maintained within the range 150 rev/min to 800 rev/min and relates to cutters of $\varnothing 24$ mm to $\varnothing 127$ mm ($\varnothing 0.95$ in to $\varnothing 5.0$ in).

The surface cutting speed is not maintained if cutters smaller than $\varnothing 24$ mm ($\varnothing 0.95$) or larger than $\varnothing 127$ mm ($\varnothing 5.0$ in) are used.

First touch – machine feed rate

The feedrate (f) is calculated as follows:

$$f = 0.16 \times \text{rev/min} \quad f \text{ units mm/min (diameter set)}$$

$$f = 0.12 \times \text{rev/min} \quad f \text{ units mm/min (length set)}$$

Second touch – machine feed rate

800 rev/min, 4 mm/min (0.16 in/min) feedrate.

Software routines

Software routines for tool setting are available from Renishaw for various machine controllers and are described in data sheet H-2000-2289.

Specification	
Sense directions	Normally mounted to sense in the machine's $\pm X$, $\pm Y$ and $-Z$ axes
Uni-directional repeatability	1 μm (0.00004 in). Maximum mean 2 sigma (2σ) value*
Stylus trigger force	1.3 N to 2.4 N / 130 gf to 240 gf (4.6 ozf to 8.5 ozf) depending on sense direction
Temperature Operating Storage	+5 °C to 60 °C (41 °F to 140° F) -10 °C to 70 °C (14 °F to 158 °F)
*Valid as tested with a 35 mm straight stylus and a velocity of 480 mm/min in the centre of the stylus tip	
Disc stylus Tungsten carbide 75 Rockwell C. Ø12.7 mm × 8 mm (Ø0.5 in × 0.31 in)	Square stylus Ceramic tip, 75 Rockwell C. 19.05 mm × 19.05 mm × 8 mm (0.75 in × 0.75 in × 0.31 in) Ø19.05 mm (0.75 in)

Interface unit

The MI 8-4 interface is fully described in user's guide H-2000-5008. The alternative MI 8 interface is fully described in user's guide H-2000-5015.

The MI 8-4 interface is used with the standard G31 SKIP type control probe input. The probe's status output operates between 4.75 Vdc and 30 Vdc.

All inputs are fully configurable for ACTIVE HIGH and ACTIVE LOW operation.

The interface also includes an 'inhibit' function, as well as a facility for simple selection between the tool setting probe and an inspection probe.

The MI 8 interface is used with the standard G31 SKIP type control probe input. Probe status output is a voltage-free SSR (solid state relay) which is invertable via a switch (SW1).

Maximum current 50 mA peak

Maximum voltage ± 50 V peak

An inhibit function is included, and a facility to drive an external probe status LED.

dimensions mm (in)

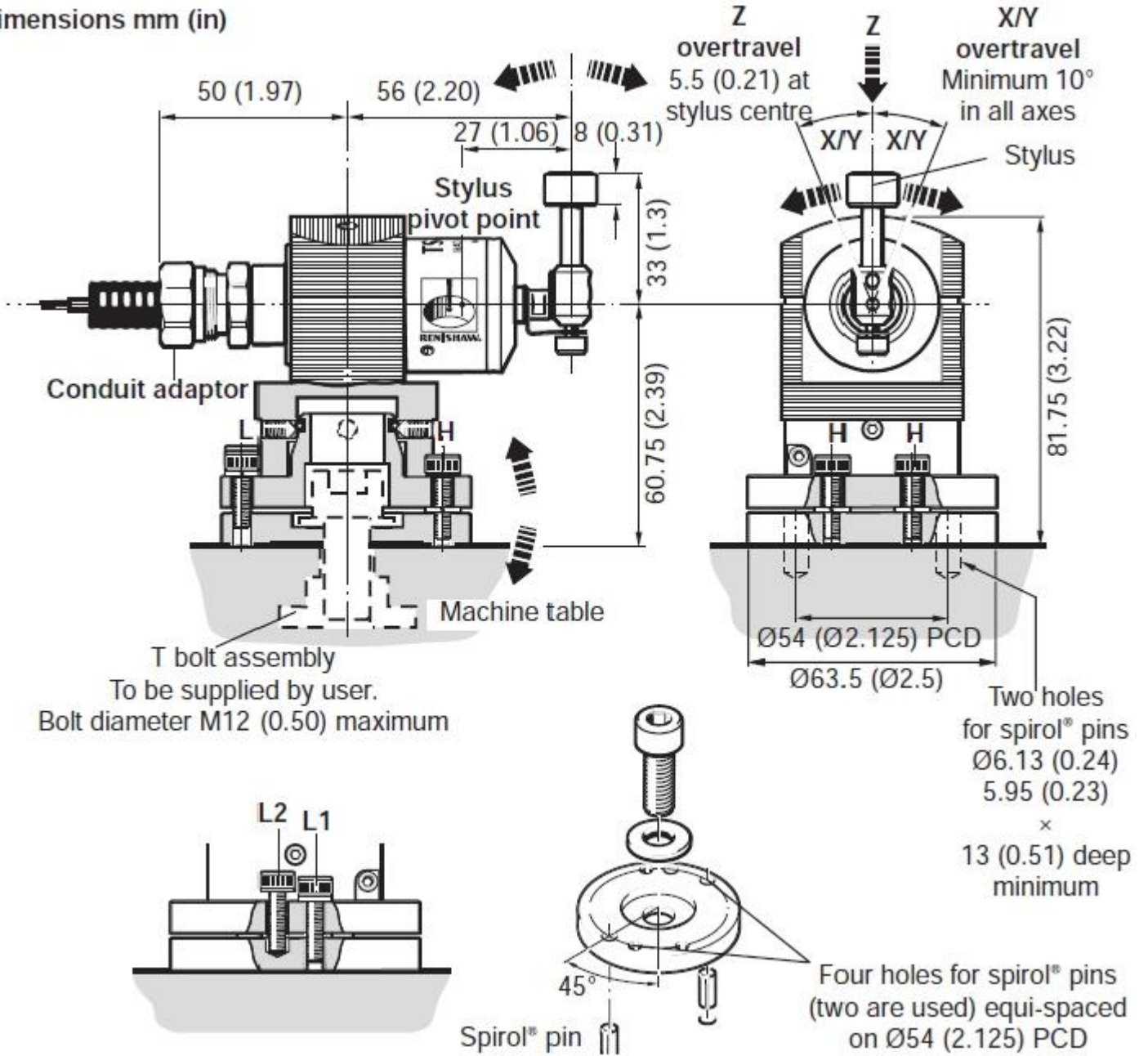

Mounting the probe on the machine table

1. Select a position for the probe on the machine table.
2. Detach the probe base and the plinth from the probe by removing the two screws H and the screw L1 using a 4 mm AF hexagon key.
3. Fit the T bolt (not supplied by Renishaw).
4. Tighten the T bolt to secure the probe base to the machine table.
5. Refit the probe and plinth onto the base and fit the screws. Tighten the two screws H firmly. Keep the adjusting screws L1 and L2 loose before setting the stylus alignment (see page 1-12).
6. Fit the stylus (see pages 1-10 and 1-11).

Spirol® pins (see page 1-4)

The T bolt provides adequate clamping for all normal circumstances. However two Spirol® pins (supplied in the probe kit) may be fitted on installations where there is a requirement to remove and remount the TS27R. To fit the Spirol® pins, drill two holes in the machine table to correspond with two of the probe base holes. Place the Spirol® pins in the holes and refit the probe base.

Cable

Four-core 7/0.2 polyurethane insulated and screened cable 10 m (32.8 ft) long. Cable

diameter 4.4 mm (0.17 in). Probe circuit – red and blue cores (yellow and green not used).

Extension cable (15 m maximum extension)

Maximum permitted cable length:

Probe to interface – 25 m (82 ft) long

Two-core 7/0.2 mm polyurethane insulated and screened cable. Maintain the screen through the joins.

Conduit for cable protection

Renishaw recommends that Thomas and Betts Type EF conduit, or a suitable alternative, is fitted to all installations. The TS27R conduit adaptor accepts Ø11 mm (0.43 in) flexible conduit.

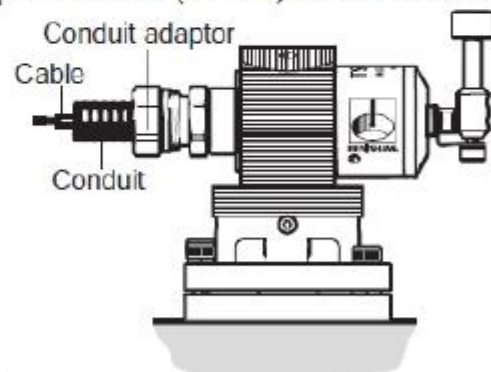
**Note:**

The cable screen is connected to the machine via a 100 nF capacitor inside the TS27R to prevent possible earth loops. Ensure the cable screen is connected to the appropriate input on the interface.

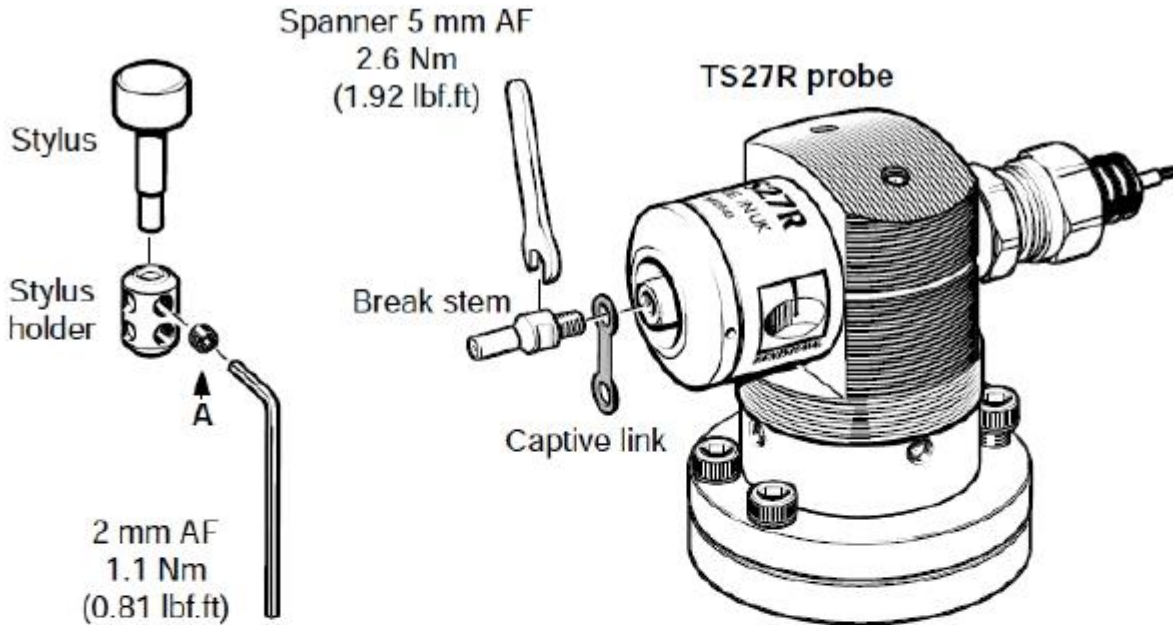

Screw torque values

Tighten all the screws to the torque values shown, remembering to use the support bar whenever adding or removing parts attached to the break stem (see page 1-11).

Fitting the stylus

The stylus is retained in the stylus holder by tightening grubscrew A.

Captive link

In the event of excessive stylus overtravel, the break stem breaks at its weakest point, preventing damage to the probe mechanism.

The captive link connected to the probe and stylus holds onto the stylus, otherwise the stylus could fall into the machine and become lost.

When a new captive link is fitted, it must be bent to accept screw C (see page 1-11).

Always hold the support bar in position to counteract twisting forces and avoid over-stressing the stylus break stem.

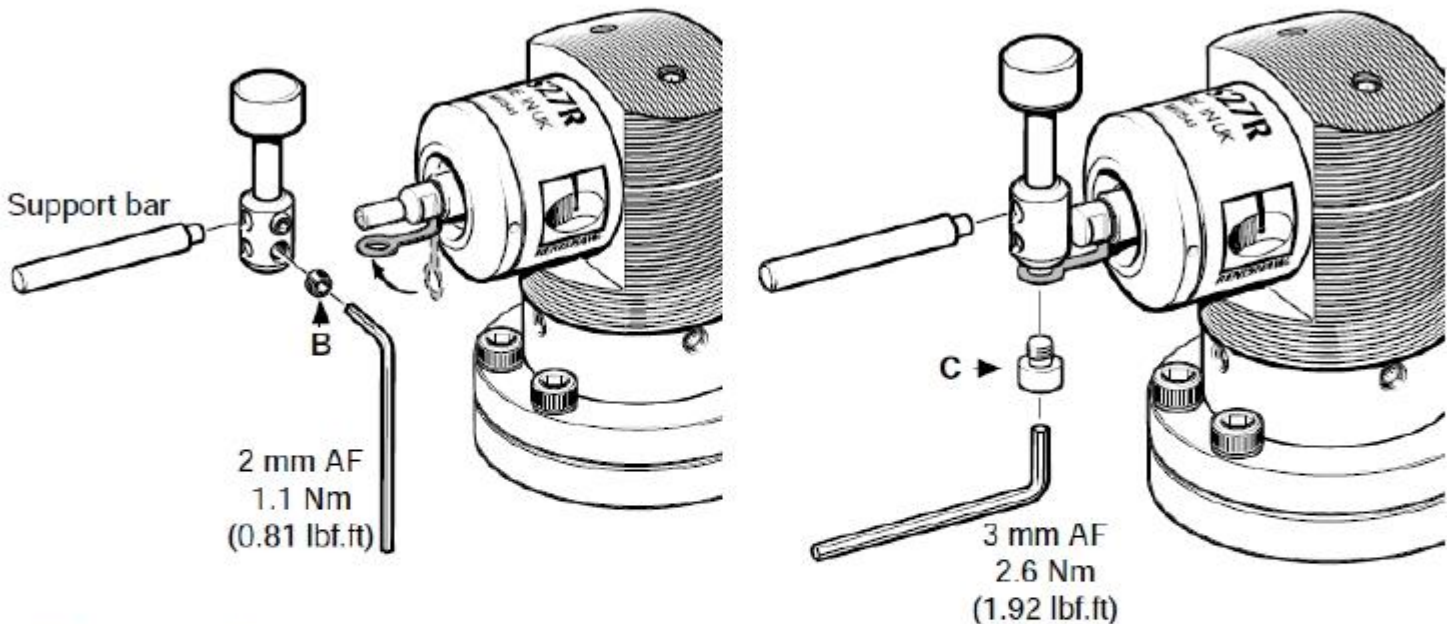

Stylus and holder

Place the stylus and holder onto the break stem and loosely fit grub screw B.

Fit screw C through the captive link and into the stylus holder, then tighten all the screws.

Replacing the break stem

Remove the broken parts and rebuild in the sequence shown above.

Note: Earlier versions of the TS27R probe were supplied with cup-pointed grub screws and a different break stem. Only fit current components supplied with this probe or with the break stem retrofit kit.

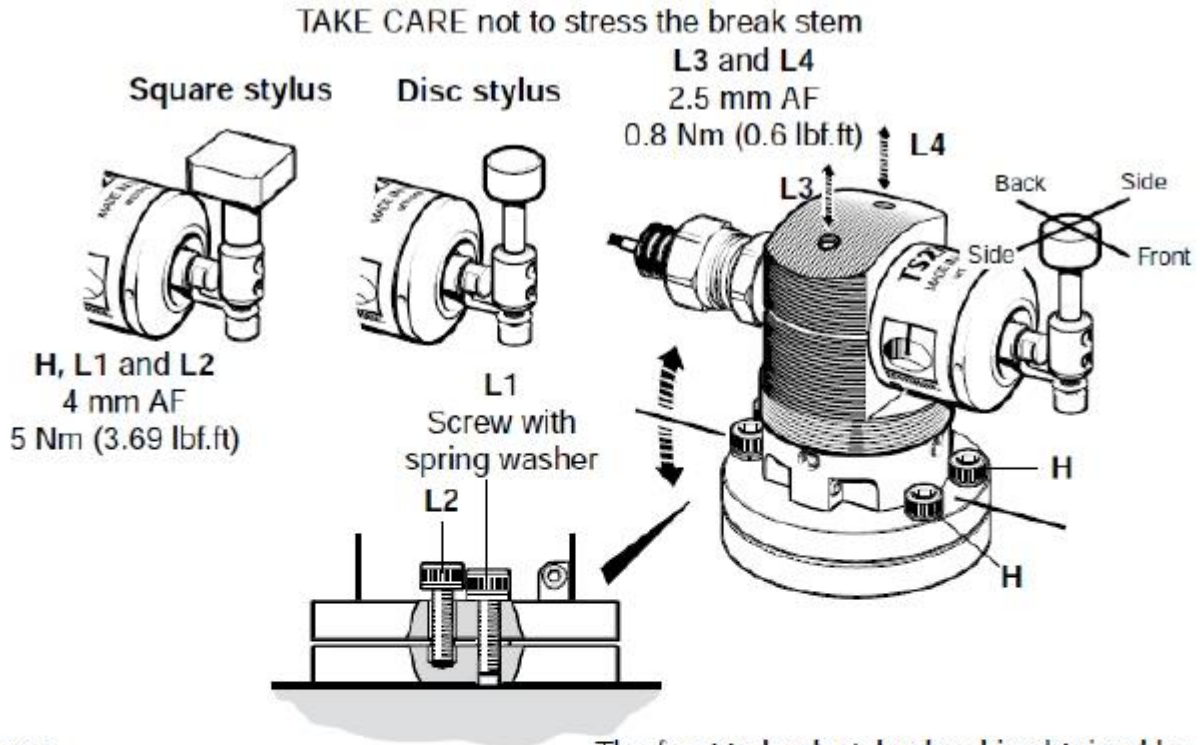

Stylus types

Disc stylus	Ø12.7 mm (Ø0.5 in)
Square stylus	19.05 mm × 19.05 mm (0.75 in × 0.75 in).

Stylus level setting

The top surface of the stylus must be set level, front to back and side to side.

The front to back stylus level is obtained by alternately adjusting screws L1 and L2, which causes the probe cable end to rise or lower, changing the stylus level setting. When a level stylus surface is obtained, tighten screws L1 and L2.

Side to side level is obtained by alternately adjusting grubscrews L3 and L4, which causes the probe module to rotate and change the stylus level setting. When a level stylus surface is obtained, tighten screws L3 and L4.

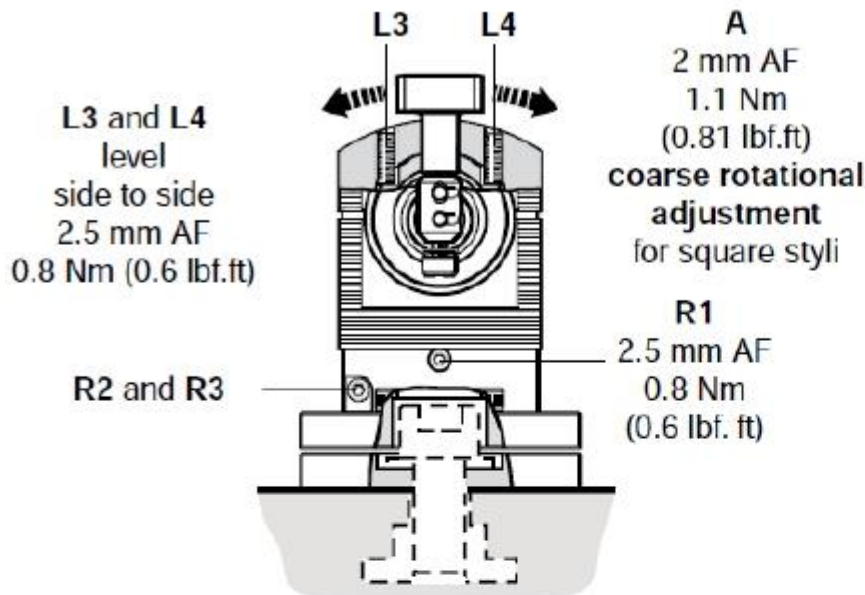

Always hold the support bar in position to counteract twisting forces and avoid over-stressing the stylus break stem.

Additional setting for square styli

Stylus level setting is the same for disc and square styli. In addition, square styli side faces can be aligned with the machine's X/Y axes.

Coarse rotational adjustment is obtained by slackening the stylus holder grub screw A, rotating the stylus in its holder, then retightening grub screw A. (Always use the support bar – see page 1-11.)

Fine rotational adjustment is obtained by loosening the four grub screws R1 and alternately adjusting the two probe rotational adjuster screws R2 and R3 until the required tip parallelism to the axes is achieved. Retighten grub screws R1, R2 and R3.

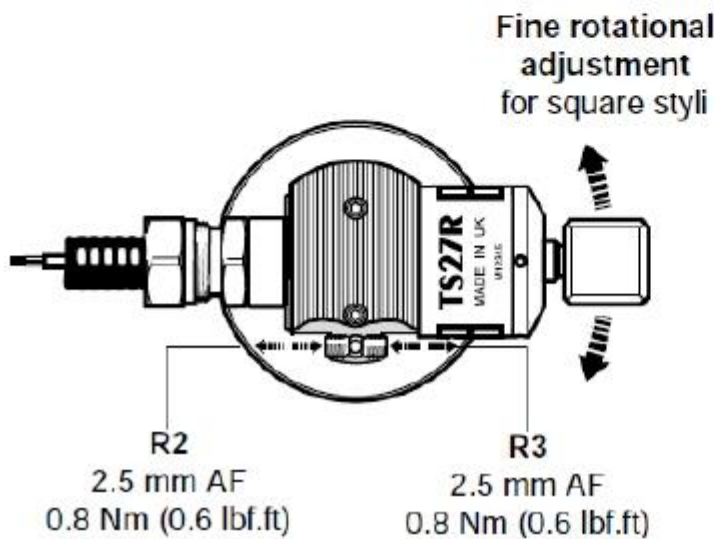

Ensure all screws are tight after adjustment.

Service

You may undertake the maintenance routines described in this handbook.

Further dismantling and repair of Renishaw equipment is a highly specialised operation, which must be carried out at authorised Renishaw Service Centres.

Equipment requiring repair, overhaul or attention under warranty should be returned to your supplier.

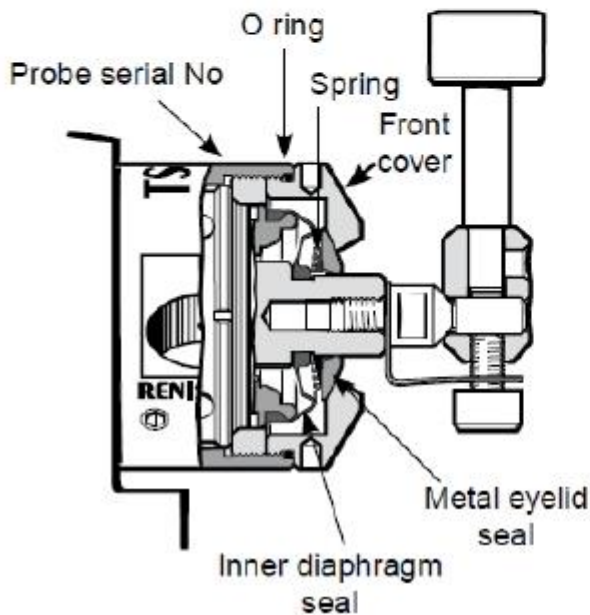
**Maintenance**

The probe is a precision tool and must be handled with care.

Ensure the probe is firmly secured to its mounting.

The probe requires minimal maintenance as it is designed to operate as a permanent fixture on CNC machining centres, where it is subject to a hot chip and coolant environment.

1. Do not allow excessive waste material to build up around the probe.
2. Keep all electrical connections clean.
3. The probe mechanism is protected by an outer metal eyelid seal and an inner flexible diaphragm seal.

Approximately once a month, inspect the probe inner diaphragm seal. If it is pierced or damaged, return the probe to your supplier for repair.

The service interval may be extended or reduced depending on experience.

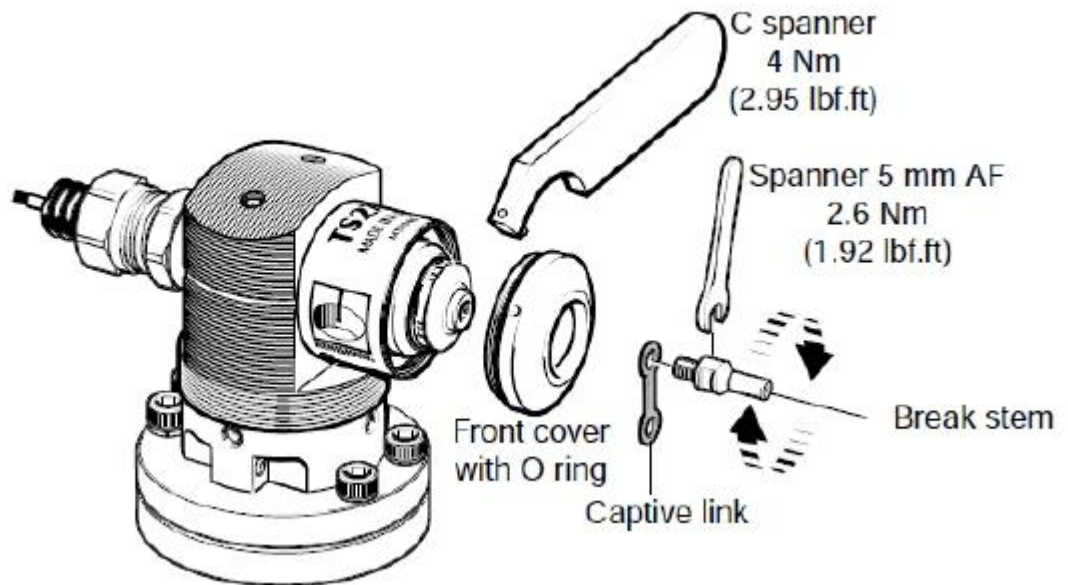

1. Remove the stylus and holder (see page 1-11).
2. Remove the break stem using the 5 mm AF spanner.
3. Use a C spanner to remove the probe's front cover. This will expose the metal eyelid seal and the inner diaphragm seal. Remove the metal eyelid and spring. CAUTION – these may fall out.
4. Wash inside the probe, using clean coolant. (DO NOT use sharp metal objects to clean out debris.)
5. Inspect the diaphragm seal for signs of piercing or damage. In the event of damage, return the probe to your supplier for repair, as coolant entering the probe mechanism could cause the probe to fail.
6. Refit the spring and metal eyelid (the spring's widest diameter is against the metal eyelid).
7. Refit the remaining components (see pages 1-10 and 1-11).

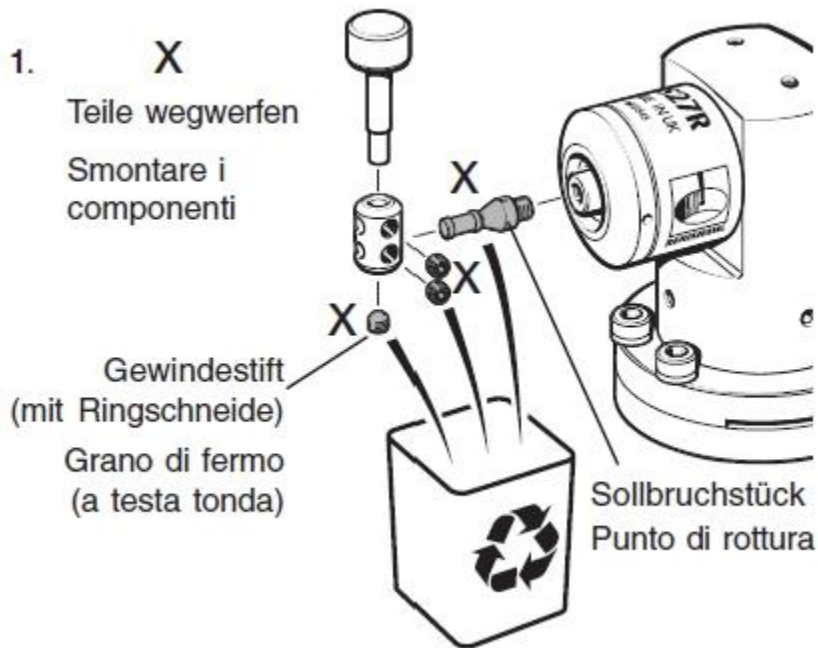

2. Sicherungsband und Sollbruchstück am Messtaster befestigen. Mit dem Gabelschlüssel SW 5 mm festziehen. Das Sicherungsband wie gezeigt ausrichten.

Installare sulla sonda il raccordo e il punto di rottura.
Stringere con una chiave da 5 mm.
Il raccordo deve essere orientato come indicato nella figura.

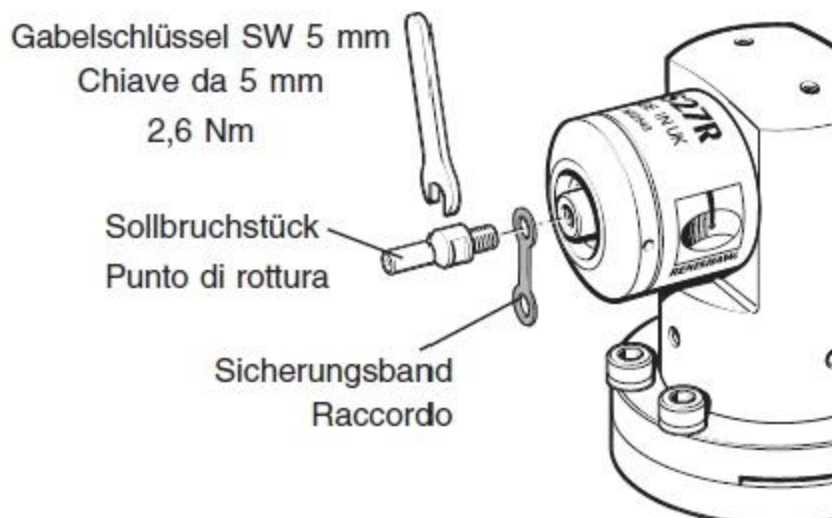

3. Tastereinsatz und Tastereinsatzhalter einbauen
Gewindestift A verwenden.
Mit 2 mm Innensechskantschlüssel anziehen.

Montare stilo e portastilo - utilizzare il grano A (a testa piatta).
Stringere con una chiave da 2 mm.

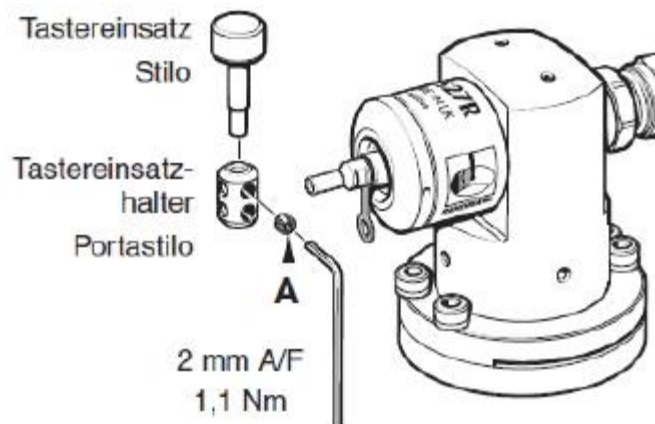

4. Tastereinsatz/Halter am Sollbruchstück befestigen.
Unbedingt den Montagegriff beim Anziehen des Gewindestiftes B (mit 2 mm Innensechskantschlüssel) verwenden, um das Sollbruchstück nicht zu beschädigen.

Installare il gruppo stilo/portastilo sul punto di rottura.
Quando si stringe il grano B (a testa piatta), utilizzare la barra di supporto per evitare di sottoporre lo stilo a sollecitazioni eccessive.
Stringere con una chiave da 2 mm.

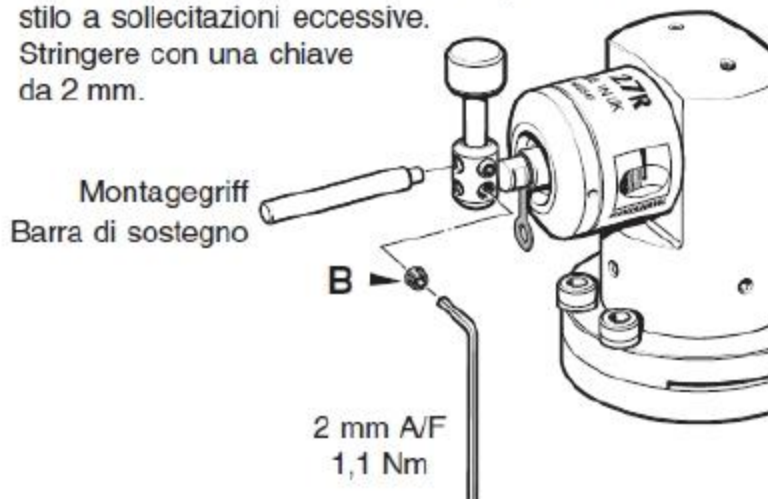

5. Das Sicherungsband umbiegen und mit Schraube C befestigen. Unbedingt den Montagegriff beim Anziehen der Schraube C (mit 3 mm Innensechskantschlüssel) verwenden, um das Sollbruchstück nicht zu beschädigen.

Piegare il raccordo e inserire la vite C (a testa piatta).
Quando si stringe la vite C, utilizzare la barra di supporto per evitare di sottoporre lo stilo a sollecitazioni eccessive.
Stringere con una chiave da 3 mm.

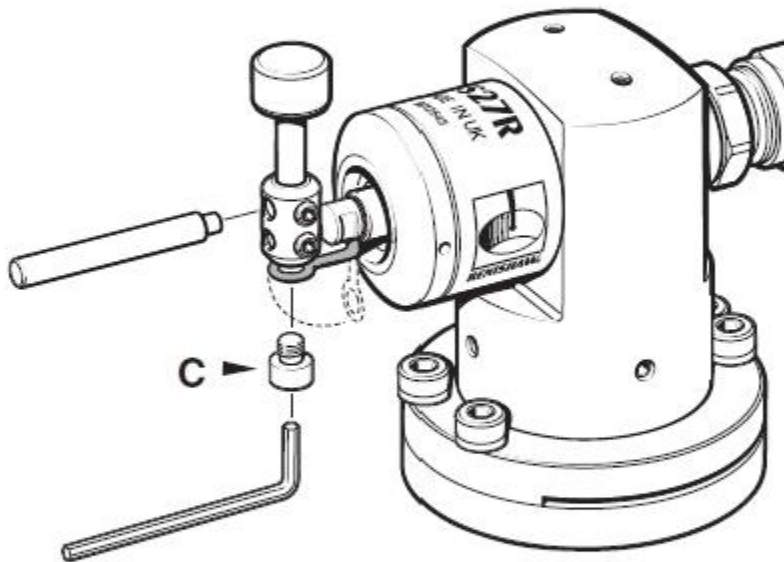

3 mm A/F
2,6 Nm

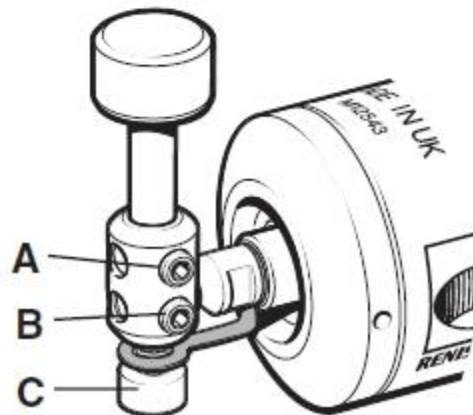

探針調整步驟：

- (1) Put the dial gauge on the main shaft and adjust the horizontal level of the stylus to **3 μ** or less.

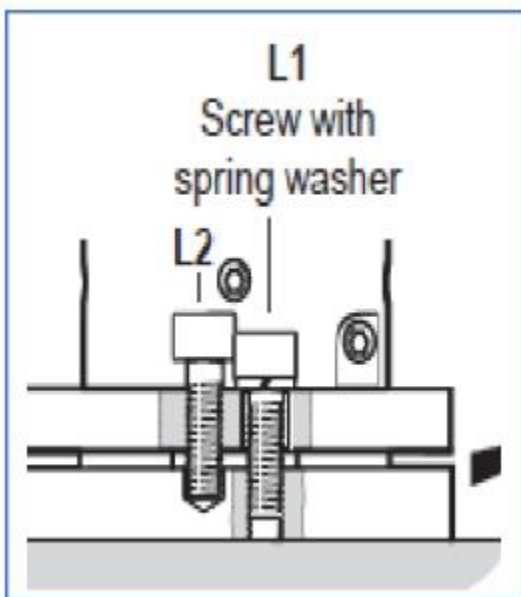

- (2) L1 and L2 bolts at the back of TS27R can be used to adjust the pitch angle (Front/Back).

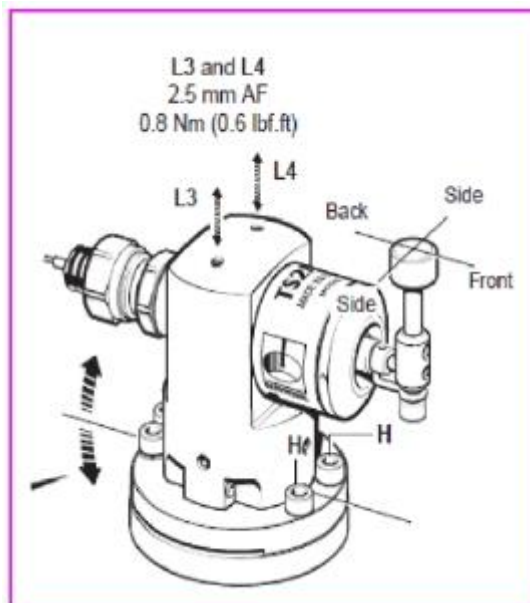

- (3) L3 and L4 fine tuning bolts on top of TS27R can be used to adjust the degree of offset (Side).

*If the front is too high, loose the L1 bolt but tighten up the L2 bolt. Do the opposite if the back is too high.

*If the side of the L3 bolt is slightly higher, loose the L4 bolt and tighten up the L3 bolt. Do the opposite if the L4 bolt that is slightly higher.

* The diameter of the column-style stylus: 12.7mm.

Software setup and calibration:

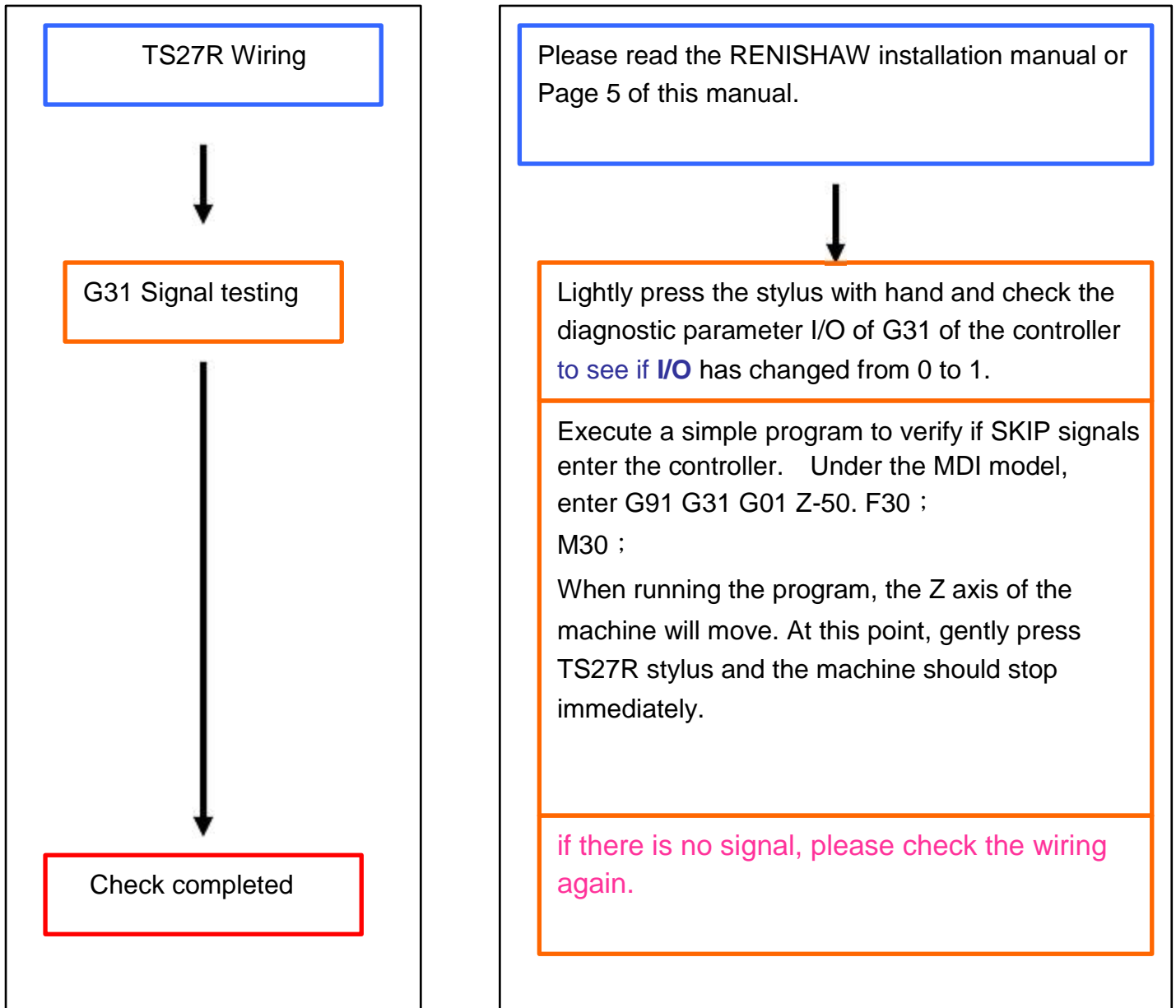

SKIP signal :

FANUC : X4.7 (18M)or X1004.7or F122 (High speed SKIP I/O)

Software Installation Descriptions :

System

Annotations for System Setup:

- (1) System Setup
- Select the controller model
- For the ...i series controller, put a tick here
- Machine parameter Setting
- Metric vs. English setting unit
- TS27R installation orientation
- Measuring orientation: positive or negative

Annotations for Advanced Setup:

- (2) Advanced setup for using two sets of probes and OTS or axial swapping
- Main shaft orientation
- X axis safe retract position
- Y axis safe retract position
- Two measuring position
- Selection code of probe of the second set
- Where variables of probe of the second set are saved
- Select the OTS system
- OTS (M-code function on)
- OTS (M-code function off)

Tool Data

Tool offset Type A ▾
 <=200 offsets ▾
 Radius offset ▾
 10 Tools above this diameter rotate
 100 Diameter above value will set on one side

(3) Cutter related Setup
 Select type of Tool compensation
 Select the number of Tool compensation
 Tool diameter compensation (radius/diameter)
 Spindle will running if the value exceeds the cutter diameter
 Select Tool side for measurement

Software Setup

English ▾ Message language
 520 Variable base number
 G31 ▾ Skip format
 100 Initial approach position
 10 Clearance position above the stylus
 5000 Fast positioning feed rate
 Tick, to out put macros into seperate programs
 Click here for Advanced software settings (defaults recommended)

(4) Software setup
 Language option (Error message)
 Initial numbers for co-variables Style of
 SKIP signal points
 The first safety retract height
 (from cutter tip to stylus)
 The second safety retract height
 (from cutter tip to stylus)
 Setting up the high speed feed rate
 Splitting into separated programs

Click here for Advanced software settings (defaults recommended)

0.005

Zone check

5

Overtravel

5

Radial clearance when setting a diameter.

.3

Backoff factor during measure moves

200

First touch feed rate

(5) Advanced Software setup

(Avoid changing the default values)

Position error

Travel displacement

Offset of cutter diameter

measurement

Withdraw quantity First contact feed rate

Long Tool Short tool Search

0

Maximum tool length

0

Minimum tool length

2000

Feed rate from long to short tool search

Measurement and calibration program:

Program codes	Program descriptions
O9750	Variable store (Basic parameter setup)
O9855	Calibrating the stylus (Stylus calibration program)
O9856	Manual tool length setting (Manually measuring the length of the cutter)
O9857	Auto length and diameter setting (Auto-cutter length/Cutter diameter measuring program)
O9858	Rotating tool broken tool cycle (Broken cutter check program)

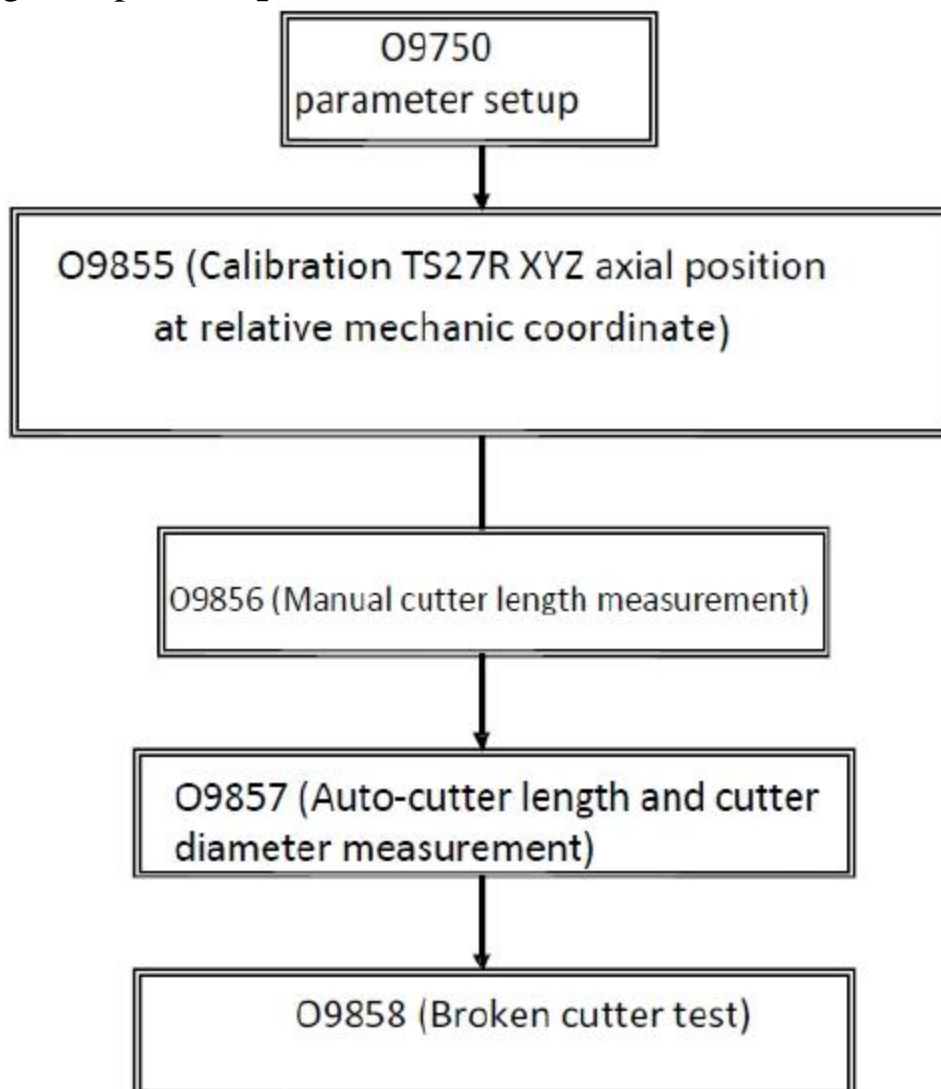
Measuring program operation procedure:

Macro programs and setup: (Set the parameters before calibration.)

Variables	Content	Descriptions
#101	200	The first stylus contact feed rate
#102	3	Compensation type (1 = A, 2 = B, 3 = C); default = 1
#103	1	Single side measuring setup
#104	2	TS25 direction setup (Please refer to the factory manual).
#105	0.3	Withdraw quantity (please refer to the default manual); default = 0.3
#106	0	Dual stylus (0 = NO, 1 = Yes)
#107	1	Metric vs. English system (1 = mm, 0.04 = inch); default = 1
#109	1	Compensation of the radius or the diameter (1 = radius, 2 = diameter); default = 1
#110	10	Radius offset (when measurement cutter length)
#111	100	If the cutter diameter is greater than this value, single-sided measurement will be carried out.
#113	100	The first safety retract height (from cutter tip to stylus)
#114	10	The second safety retract height (from cutter tip to stylus)
#117	5	Over Travel displacement (default = 5)
#118	0	OTS probe (yes=1,NO=0)
#120	520	Position of the variables; default = 520
#121	1	Multi-axes setup: X axis (Please refer to the factory manual for the setup))
#122	2	Multi-axes setup: Y axis (Please refer to the factory manual for the setup))
#123	3	Multi-axes setup: Z axis (Please refer to the factory manual for the setup))
#124	2000	Feed rate from the longest cutter to the shorted cutter; default = 2000
#125	5	Offset of cutter diameter measurement; default = 5
#127	5000	High speed feed rate; default = 5000
#128	1	Language option: 1 = English, 2 = German, 3 = French, 4 = Italian
#138	200	Setup of the longest cutter (for a negative cutter length, enter negative value)
#139	30	Setup of the shortest cutter(for a negative cutter length, enter negative values)
#145	0.005	Error value determination; default = 0.005

Setting up TS27R Orientation :

[# 10 4 、 #1 03 = sett ing up TS2 7 R orientation](#)

Position	Probe orientation #104	Side selection #103
1	2	1
2	2	-1
3	1	-1
4	1	1
5	-2	-1
6	-2	1
7	-1	1
8	-1	-1

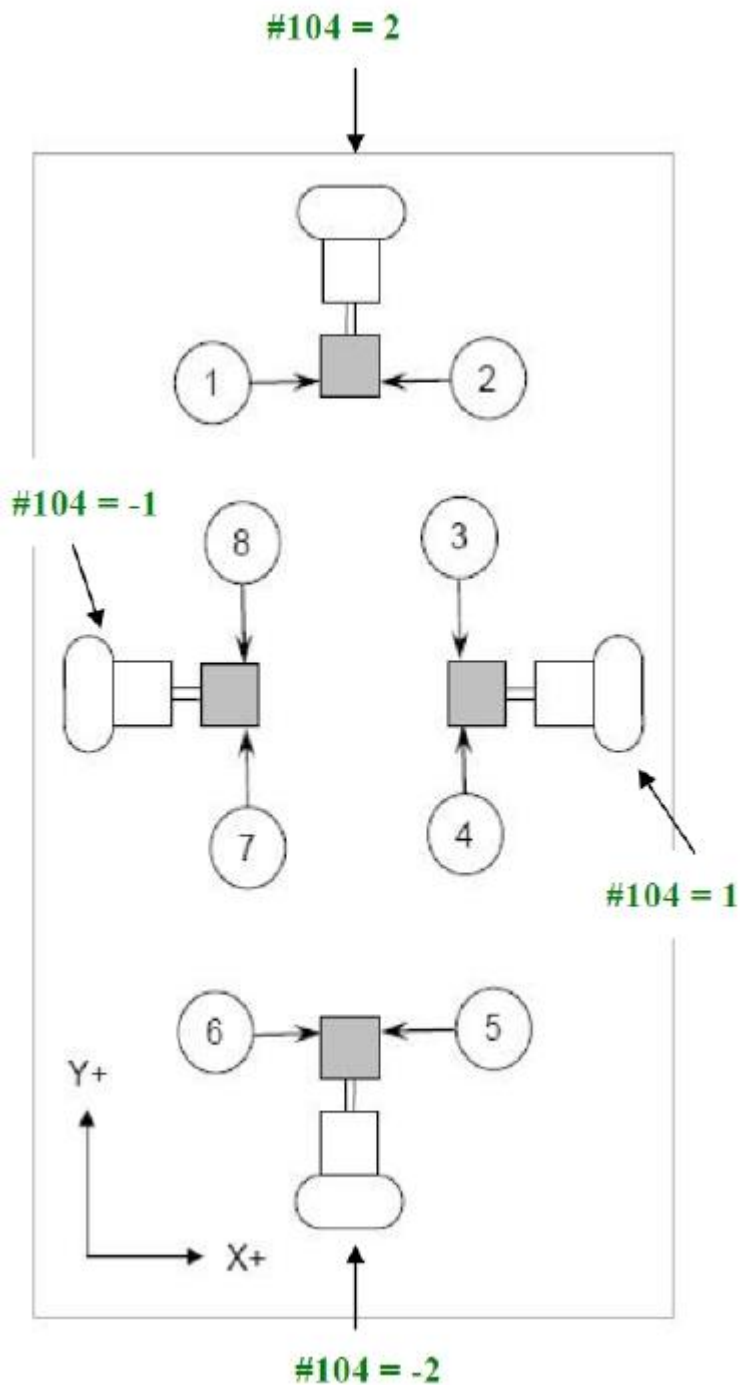

TS27R Software calibration:

Column probe
 O8000;
 G65 P9855 **D12.7 R8. T1.**;
 M30 ;

Co-variables are saved by the calibrated values;
 # 520 : Error of Z axial length
 # 521 : Value of the stylus' X axis
 # 522 : Value of the stylus' -X axis
 # 523 : Value of the stylus' Y axis
 # 524 : Value of the stylus' -Y axis
 # 525 : Error of Z axis length (still)
 # 526 : Error of Z axis length (in motion)

Square stylus
 O8000;
 G65 P9855 **R12.T1.X5.Y19.**
 M30;

(1) Prepare a reference cutter that the length and diameter are known (Precision values)
 (2) Manually move the reference cutter to 10mm above the stylus. Visually move the cutter as close to the center of the stylus as possible.

T1 : Enter the actual No.1 tool length into compensation

R8 : Diameter of the reference cutter is 8mm.

D12.7 : Diameter of the stylus is 12.7mm.

X: Width of the stylus at the X axis

Y: Width of the stylus at the Y axis

(Qq, Zz) can be included
 Qq: Distance of the travel
 Zz : Displacement of the Z axis when measuring the diameter of the cutter of the stylus

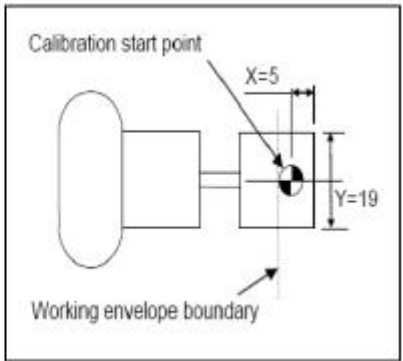
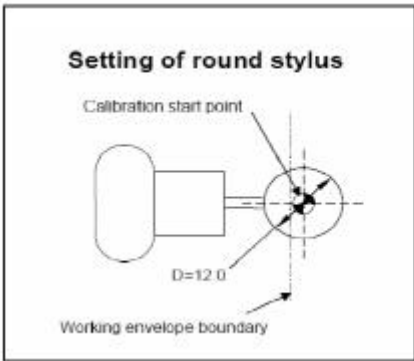

TS27R Measuring programs:

<p>Manual cutter length measurement O8001; G65 P9856 T8. ; M30;</p>	<p>Move the to-be measured cutter to about 10mm above the stylus of TS27R. Manually move the radius of the cutter so the tip of the cutter is at the center. Run this program to measure the length of the cutter and save the value in cutter compensation No.8.</p>
<p>Manual cutter length measurement (in motion) O8002; G65 P9856 D12. ;</p>	<p>D12 = Cutter diameter If cutter diameter exceeds 10mm, the radius measurement will be shifted.</p>

Basic program structure G65 P9856 [Tt Dd]
[] can be added and entered

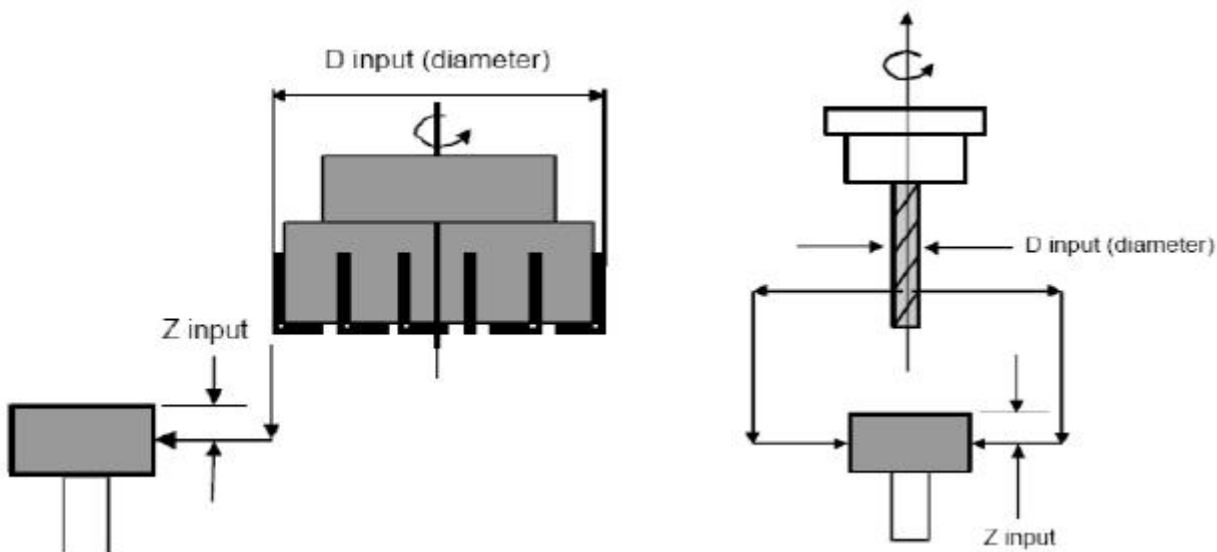

Manual measurement:

Move the cutter to 10mm above the stylus before carrying out the manual measuring program.

There is no need to enter an approximated cutter compensation value into the compensation number.

Automatic measurement:

Enter an approximated cutter length of the radius into the compensation number for the program to determine how much the Z axis has to descend.

<p>Automatic cutter length measurement O8003; G65 P9857 B1 T4. ; M30;</p>	<p>B1→ Automatic cutter length measurement T4.→ After the measurement, the actual cutter length is updated in the cutter compensation No. 4.</p>
---	--

<p>Basic program structure G65 P9857 B1 Dd [Hh Kk Mm Qq Tt Yy] [] can be added and input Dd : Cutter diameter Hh : Tolerable error Kk : Empirical error value of the machine Mm : Input M1 to avoid the message of “tool out of tolerance alarm,” and change could occur in variable #146 (from 0 to 1).</p>	<p>Qq: Distance of travel (Default: 5mm) Yy: Manually input cutter length</p>
---	---

<p>Auto-cutter diameter measurement O8004; G65 P9857 B2 T1. D12. ; M30;</p>	<p>B2→Auto-cutter diameter measurement T1→Enter the approximated cutter length into compensation No. 1. D12→Cutter diameter</p>
---	---

<p>Basic program structure G65 P9857 B2 Dd[Ee Hh Jj Mm Qq Tt Ww Yy Zz] [] can be added and input Ee: Use A Type controller to input cutter compensation number ; B and C Type will be updated by the main shaft cutter number Hh: Tolerable error Jj: Empirical diameter of the radius Mm : Input M1 to avoid the message of “tool out of tolerance alarm,” and change could occur in variable #146 (from 0 to 1). Qq: Distance of travel (Default: 5mm)</p>	<p>Yy : Manually input cutter length Zz : Depth of the Z axis when measuring cutter diameter Ww : Use built-in safety retract height (#114) when increasing the safety retract height</p>
---	---

<p>Automatic cutter length/diameter measurement O8005; G65 P9857 B3 T1. D12. ; M30;</p>	<p>B3→Automatic cutter length/diameter measurement T1→Enter an approximated cutter length into compensation No. 1. D12 → Cutter diameter</p>
<p>Basic program structure G65 P9857 B3 Dd[Ee Hh Jj Mm Qq Tt Ww Yy Zz Kk] [] can be added and input Ee: Use A Type controller to input cutter compensation number; B and C Type will be updated by the main shaft cutter number Hh: Tolerable error Jj: Empirical diameter of the radius Mm : Input M1 to avoid the message of "tool out of tolerance alarm," and change could occur in variable #146 (from 0 to 1). Qq: Distance of travel (Default: 5mm)</p>	<p>Yy : Manually input cutter length Zz : Depth of the Z axis when measuring cutter diameter Ww : Use built-in safety retract height (#114) when increasing the safety retract height Kk : Empirical error of the machine</p>

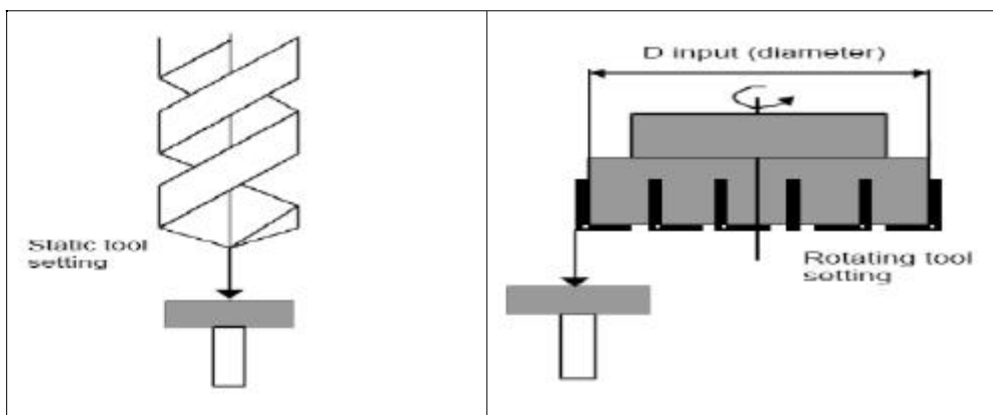

<p>Broken cutter test O8005; G65P9858 T1.H0.5.; M30;</p>	<p>H The tolerable error of broken cutter determination (this tolerable error is bi-directional) is based on the broken cutter criteria set by the user. Once the range is exceeded, abnormal alarm will go off. BROKEN TOOL H0.5 = ±0.5</p>
--	---

<p>Special cutter measurement O8006 ; G65 P9857 B4 D12. T1. ; M30 ;</p>	<p>B4→Special cutter measurement D12→Cutter diameter T1→ Enter an approximate cutter length into compensation No. 1.</p>
<p>Basic structure G65 P9857 B4 Dd[Hh Mm Qq Tt Uu Yy Kk] [] can be added and input Hh: Tolerable error Mm : Input M1 to avoid the message of “tool out of tolerance alarm,” and change could occur in variable #146 (from 0 to 1). Qq: Distance of travel (Default: 5mm)</p>	<p>Uu: Blade teeth width Yy: Manually input cutter length Kk: Empirical error of the machine</p>
Empty space for additional content	

<p>Temperature increase compensation measurement program O8007 ; G65 P9859 C2. D12. T1. X510. Y511. Z512 ; M30 ;</p>	<p>P9859 Calling temperature increase compensation program C2→Saving and comparing the mechanical coordinate values X510→Putting X axis mechanical coordinate values into co-variable No. 510 Y511→Putting Y axis mechanical coordinate values into co-variable No. 511 Z512→Putting Z axis mechanical coordinate values into co-variable No. 512</p>
<p>G65 P9859 Cc Dd Xx Yy Zz[Hh Mm Tt Ww] [] can be added and input Hh: Tolerable error Mm : Input M1 to avoid the message of "tool out of tolerance alarm," and change could occur in variable #103 (from 0 to 1). C1: Saving mechanical coordinate values C2: Saving and comparing mechanical coordinate values Tt: Cutter compensation # Ww: Safe retract height (default = 3mm)</p>	<p>Use C2 variables Put the comparing values in the co-variables. #100→X axis error #102→Z axis error #103→lag position #101→Y axis error</p>

Normal condition:

1. When the probe is not triggered, the LED on MI8 will be on.
2. Once the probe is triggered, the LED on MI8 will go off.

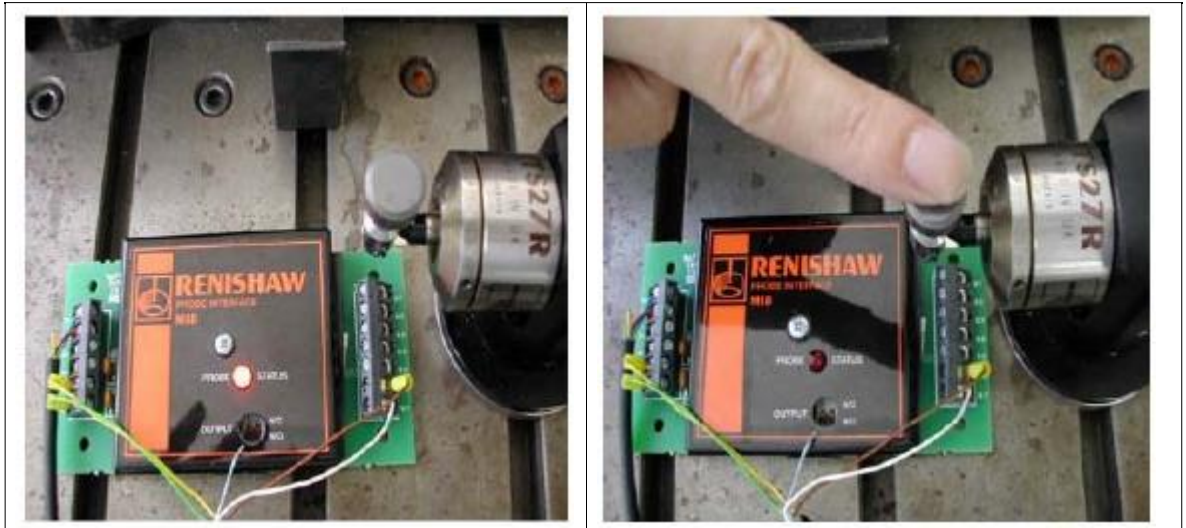

MI8 interface card troubleshooting:

- (1) T o c a u s e a Short circuit to A1 and A2. At this stage, LED on MI8 should be on (normal), while Skip signal should be 0.
- (2) After removing the short circuit of A1 and A2, MI8 LED will go off, while Skip signal will be 1. If the LED cannot be turned on or the Skip signal is wrong, the interface box of MI8 is faulty.

A1、A2 腳短路

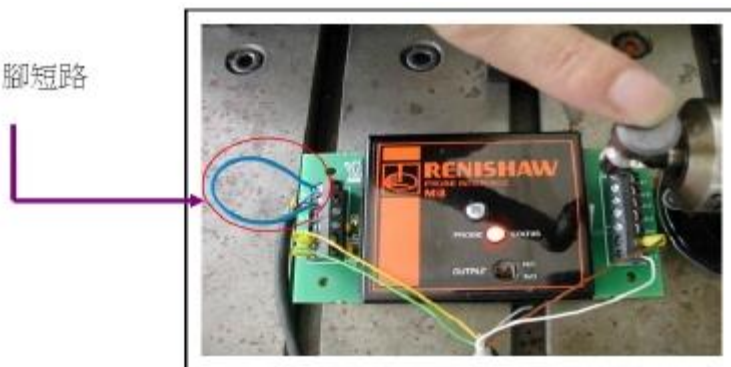

TS27R probe troubleshooting:

- (1) Use a multi meter to measure resistance of the red line and the blue line of TS27R.
- (2) If the probe is triggered, the resistance should be close to 0.
- (3) If the probe is touched, the resistance should be ∞ (displayed as 1).

If what you get is neither, then TS27R is faulty.



7. Compact Touch Probe



Specification :

Dimensions: Length (76mm), Diameter (63mm)

Unidirectional reproducibility: $\pm 1\mu\text{m}$ (2σ)

Trigger force (XY plane): Maximum $\rightarrow 1.4\text{N}$ · Minimum $\rightarrow 0.75\text{N}$

Trigger force (Z plane): 5.2N

Triggering orientation: $\pm X$ · $\pm Y$ · $+Z$

Type of batteries: 2 AA LTC batteries

Stylus full stroke: XY Plane $\rightarrow \pm 18$ · $+Z$ direction $\rightarrow 11\text{mm}$

Note for hardware installation:

For OMM/OMI-2 installation:

When installing OMM or OMI-2, it is important to pay attention to the transmission range and the angle to avoid interferences.

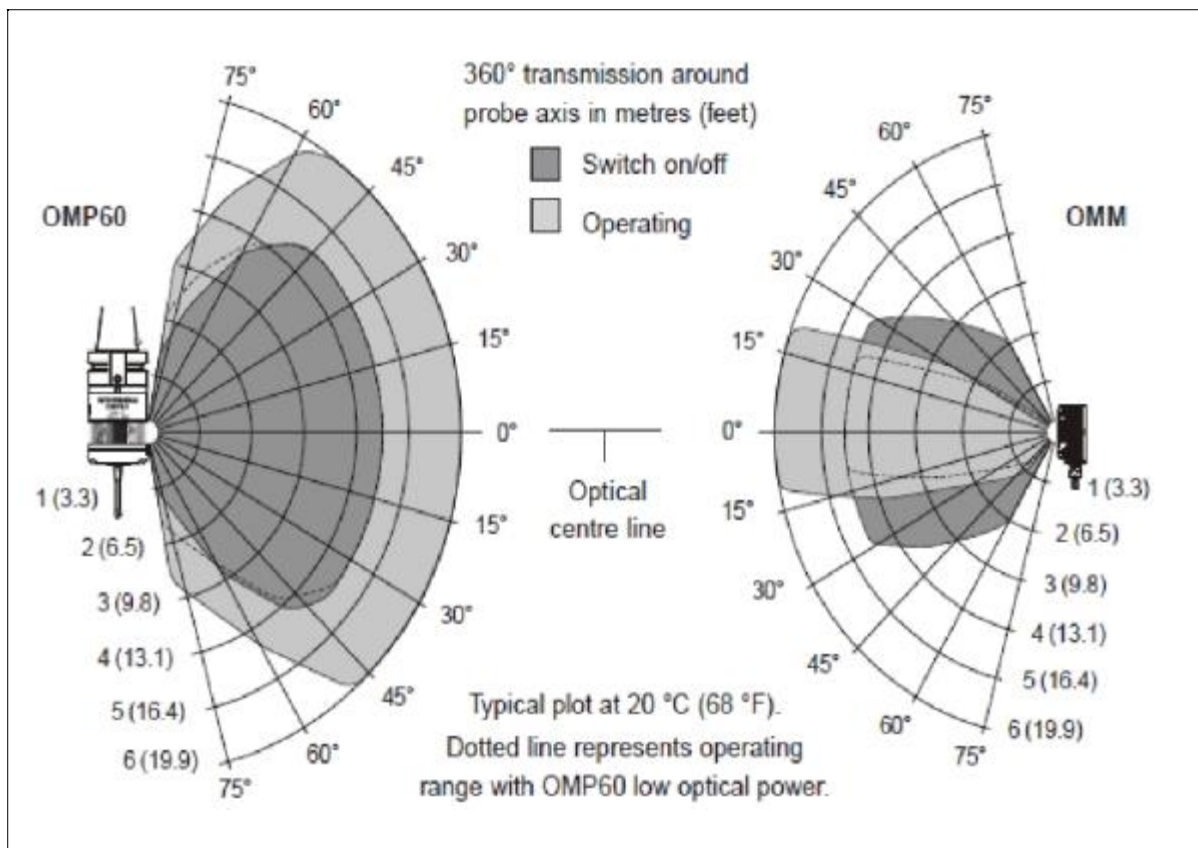

MI12 Switch setup:

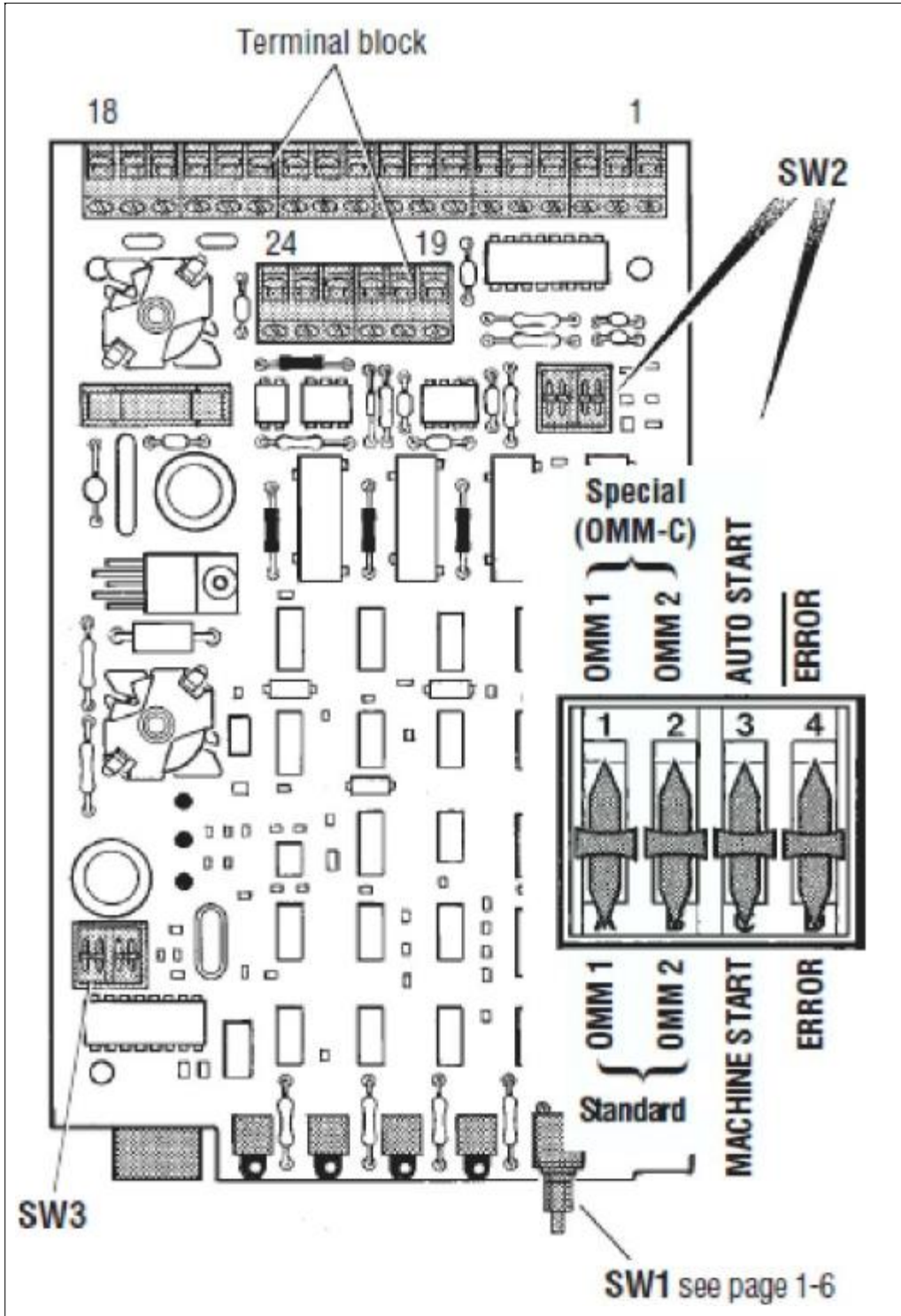

Options	14 &15 Grounding wire	23& 24 Grounding wire	SW3
1	State of the probe	State of the probe	
2	SKIP state N/C	State of the probe N/C	
3	SKIP State N/O	State of the probe N/C	
4	State of the probe N/O	SKIP State N/C	
5	State of the probe N/O	SKIP State N/O	

OMI12 Setting up the switch:

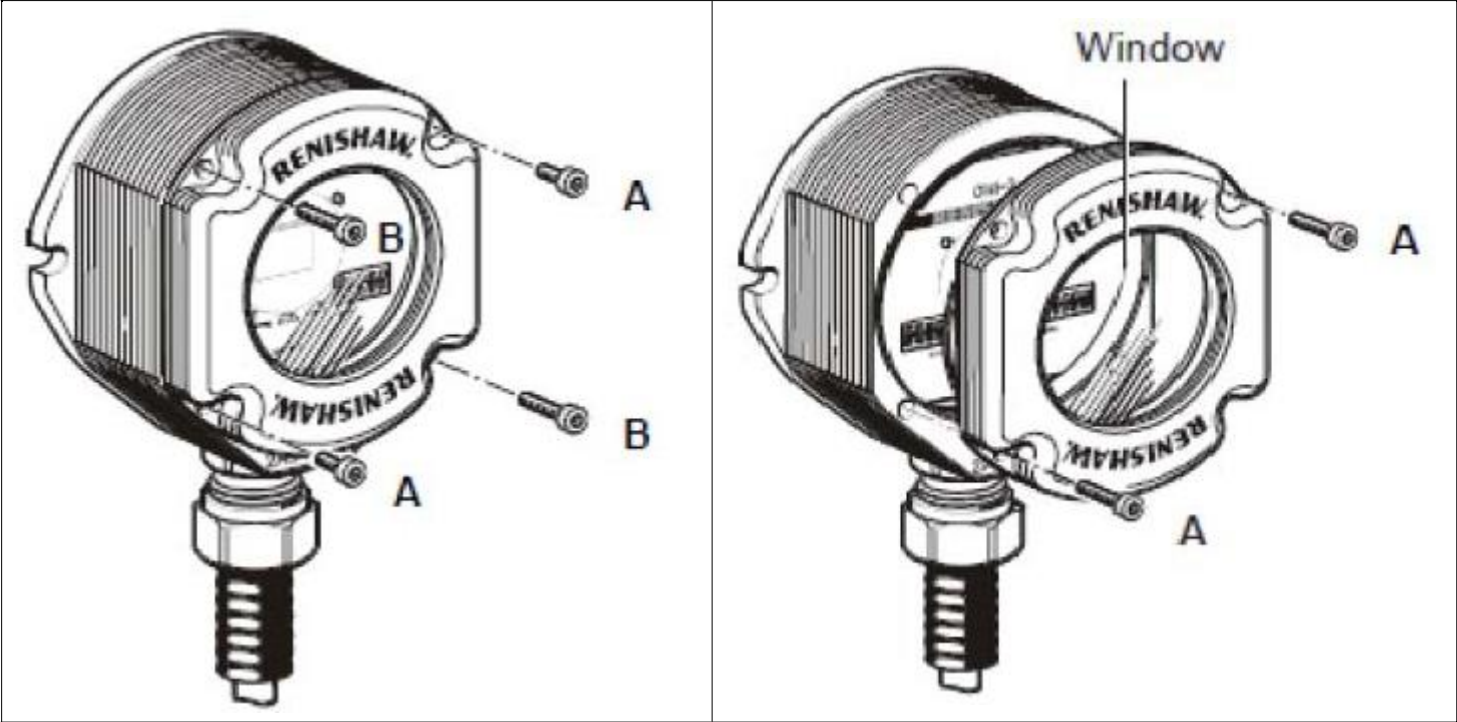

Step 1: Take out the A and B bolts.

Step 2: Remove the lens cover.
(Do not turn the lens cover, or the sealing ring may be damaged.)

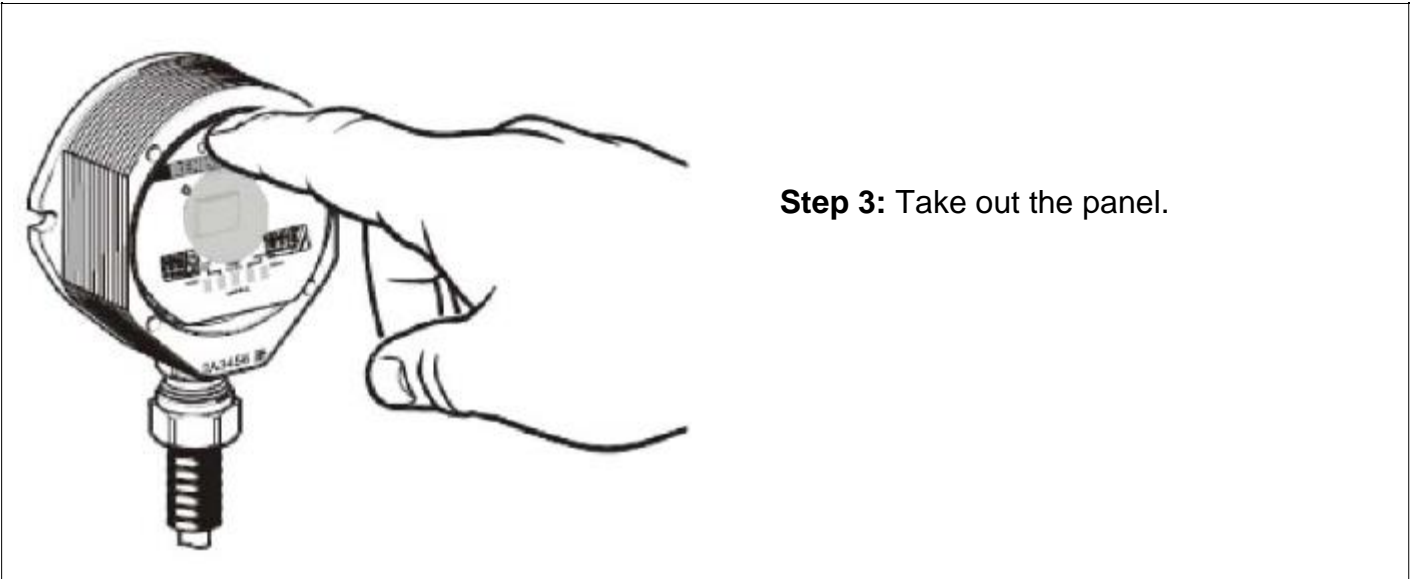

Step 3: Take out the panel.

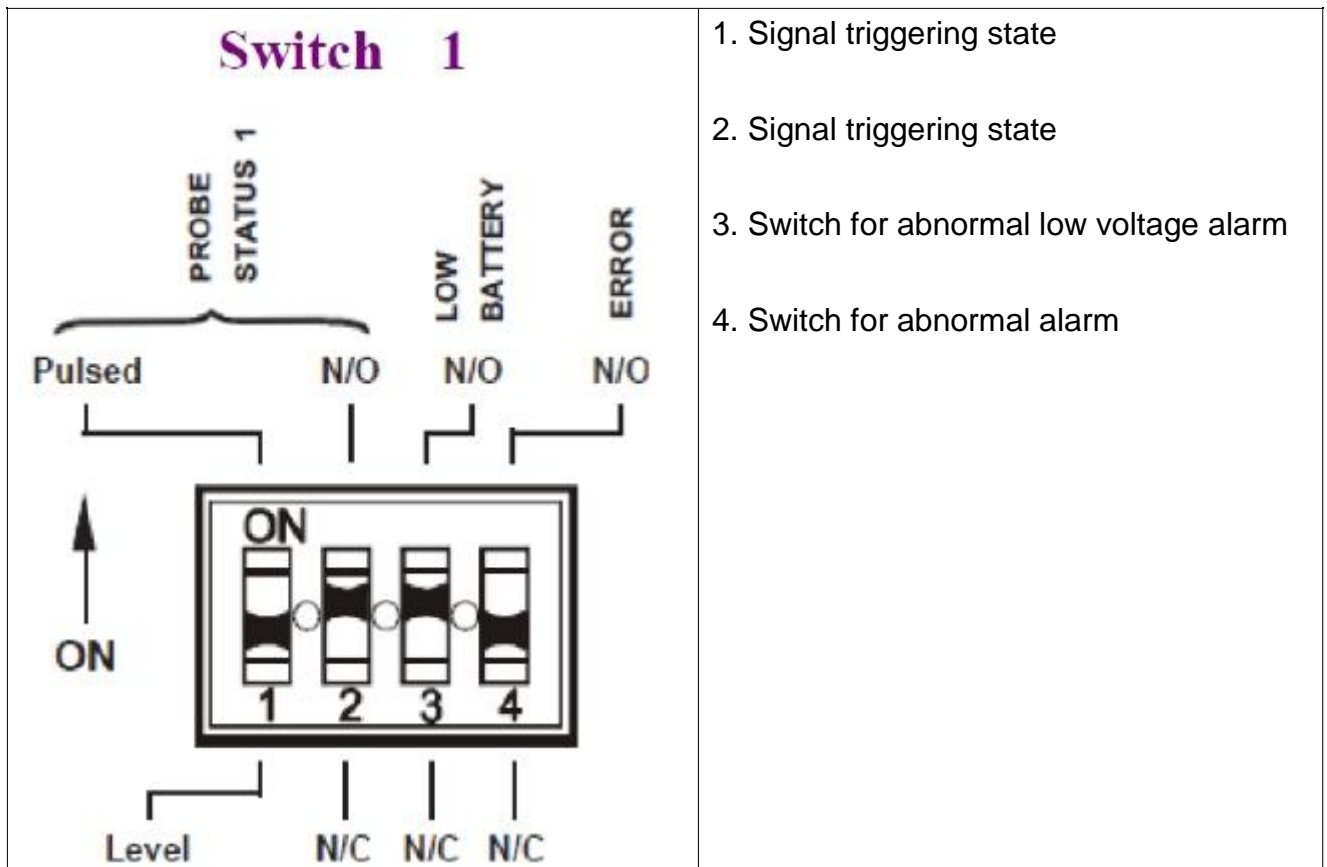
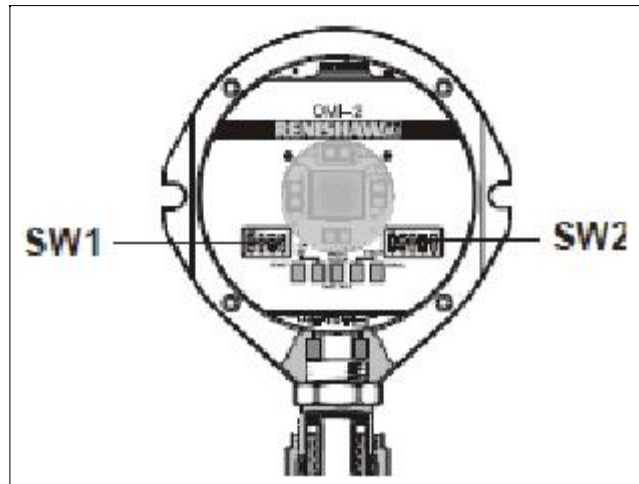

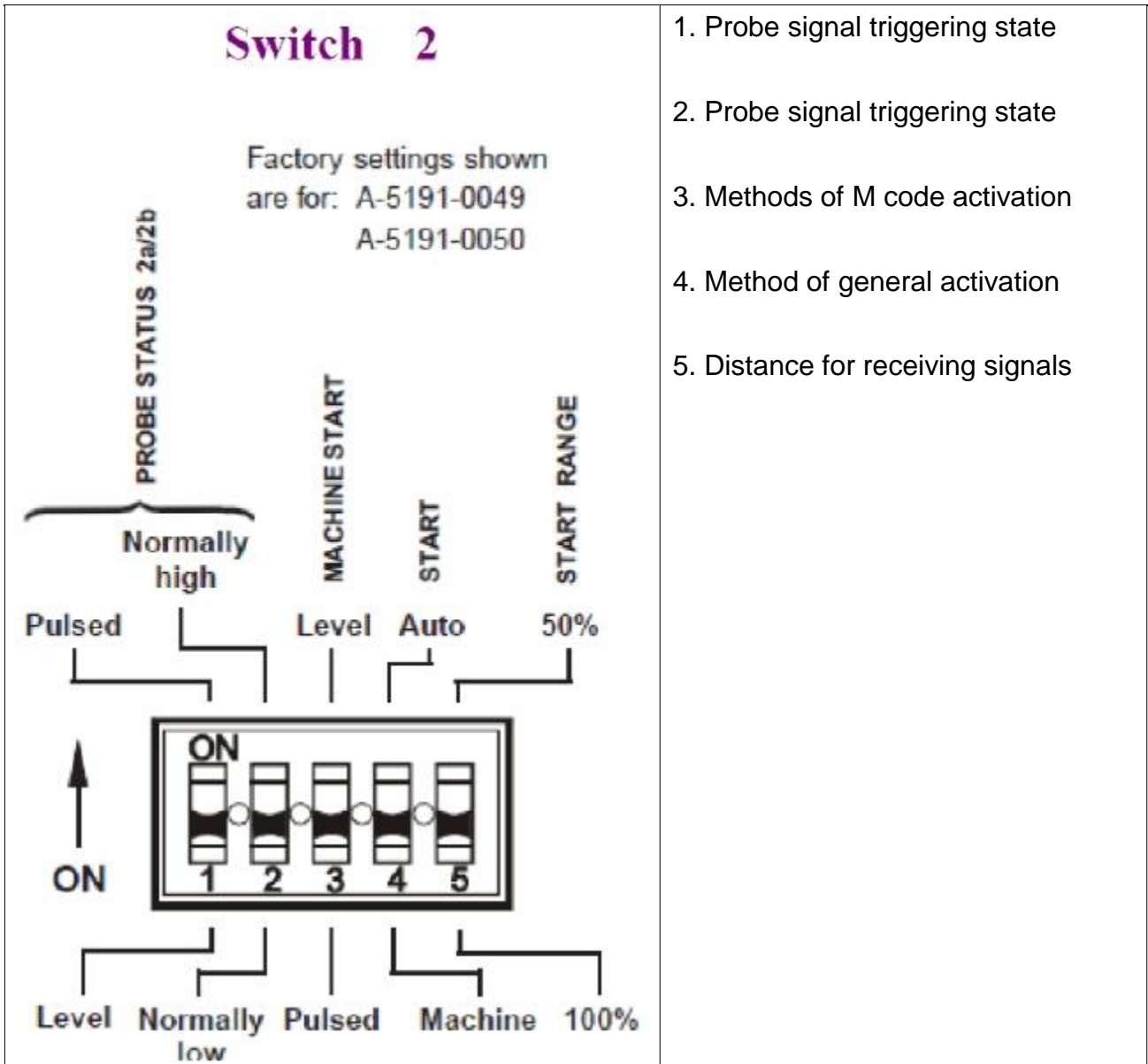

1. Probe signal triggering state
2. Probe signal triggering state
3. Methods of M code activation
4. Method of general activation
5. Distance for receiving signals

OMI-2 Light signaling :

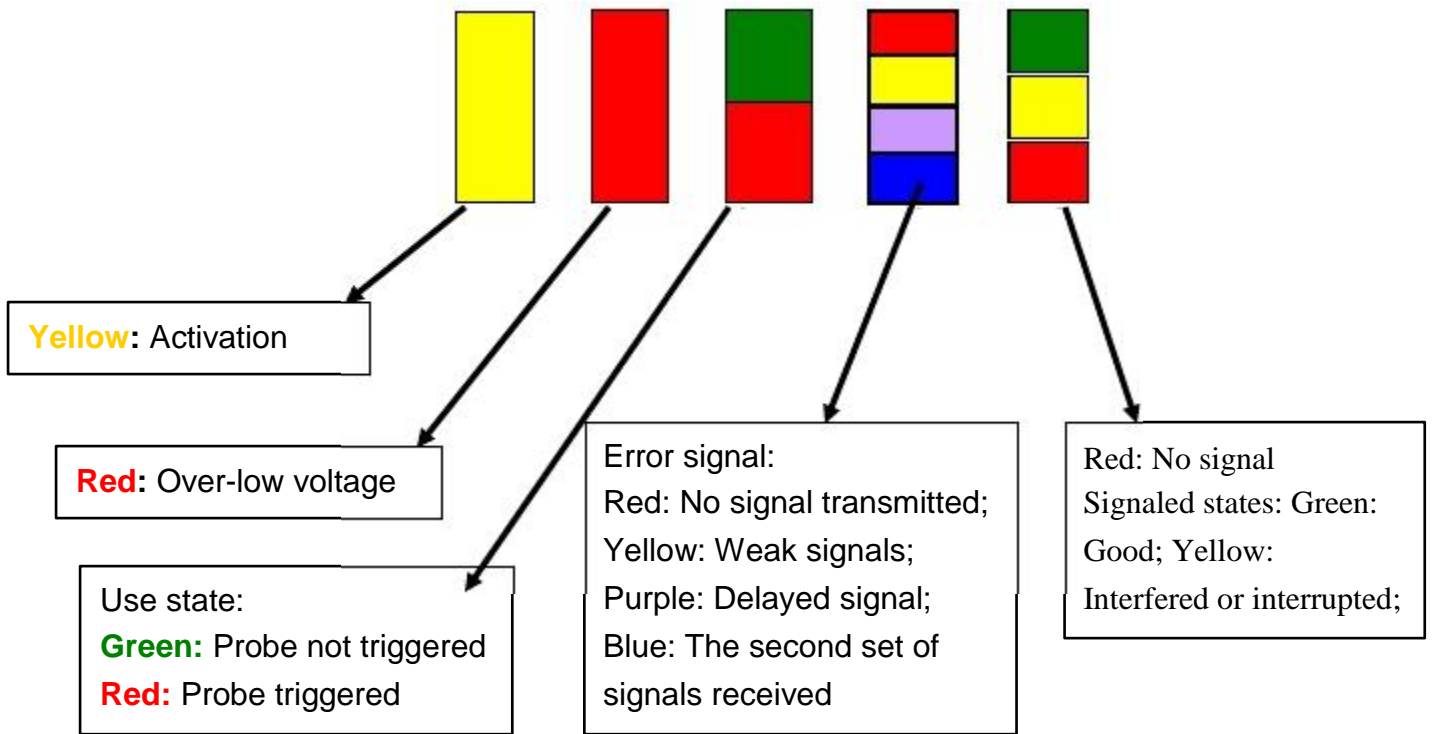

OMP60 Methods for setting up the logic:

1. Factory default inspection:

Step 1 Take out the batteries from the probe (put batteries in if it is a new probe), and then put these batteries back into the probe.

Step 2 The LED on the probe will display the following light signals continuously.



STEP 3 The LED on the probe will start to signal.

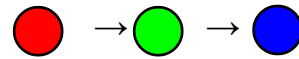

STEP 4 Methods for turning on the probe.

Optical activation	Activation by cutter holder	Activation by turning



STEP 5 Methods for turning off the probe.

Optical deactivation or deactivation by turning	Setting up short turn off period (12 seconds)	Setting up long turn off period (134 seconds)	Setting up medium turn off period (33 seconds)



STEP 6 Method for setting up logic signal filtering for probe triggering

Turn off 0 sec	Turn on 10ms	Turn on 20ms	Turn on 40ms



STEP 7 Optical transmission model

Legacy (Initial filtering Turn off)	Legacy (Initial filtering Turn on)	Modulated

**STEP 8** Battery saving setting up modes

Saving mode	Standard mode

**STEP 9** Battery volume

Low mode	Normal mode

1. Methods for setting up the logic :

STEP 1 Remove the batteries from the probe.

STEP 2 Press down the stylus slightly to create an angle (See Figure 1), and then put the batteries back to the stylus. First entering the probe setup mode, and until the red light of the probe blinks for five times, let go of the stylus to the normal condition

(See Figure 2). (如圖二)



Figure 1



Figure 2

STEP 3 Enter the logic adjustment mode.

STEP4 Methods for probe activation.

Optic activation	Activation with the cutter	Activation by turning

Gently touch the stylus (about 3 seconds) to change the option. into the next adjustment choice. When you make the choice, gently press the stylus for more than 4 seconds to enter

STEP 5 Methods for turning off the probe

Optical deactivation or deactivation by turning Setting up the short turn off period (12 seconds)	Setting up the medium turn off period (33 seconds)	Gently touch the stylus (about 3 seconds) to change the option.	Setting up the long turnoff period (134 seconds)

STEP 6 Method for setting up logic signal filtering for probe triggering

Turn off 0 sec	Turn on 10ms	Turn on 20ms	Turn on 40ms

Gently touch the stylus (about 3 seconds) to change the option. After you have made the choice, gently press the stylus for more than 4 seconds to enter into the next adjustment selection.

STEP 7 Optical transmission modes

Legacy (Initial filtering Turn off)	Legacy (Initial filtering Turn on)	Modulated

Gently touch the stylus (about 3 seconds) to change the option. After you have made the choice, gently press the stylus for more than 4 seconds to enter into the next adjustment selection.

STEP 8 Battery saving setting up modes

Saving mode	Standard mode

Gently touch the stylus (about 3 seconds) to change the option.

Do not immediately press down the stylus. Gently press down the stylus for 4 seconds or more and the procedure will go back to Step 4 and the previous setting will not be saved.

Save the setting :

Yes :

- 1) Do not touch the stylus and the setting will be automatically saved after 20 seconds. ◦
- 2) Remove the batteries from the stylus and the setting will be automatically saved.

No :

Gently press down the stylus for 4 seconds or more and the procedure will go back to Step 4.

Software setup and calibration:

Check the hardware :

Wiring of MI12 or OMI-2

Please read the RENISHAW Installation Manual or Page 5 or 8 of this manual.



G31 Signal testing

Gently press the stylus with hand and check controller G31's diagnostic parameters **I/O** to see if there is a change from 0 to 1.

Execute one simple program to verify whether the SKIP signal enters the controller.

Entry under the MDI model:

```
G91 G31 G01 X-50. F30.;
```

```
M30;
```

When executing the program, the Z axis of the machine would move. At this point, gently press the stylus of OMP60, and the machine should stop automatically.



Check completed

If there is no signal, please check the wiring again.

Location of SKIP signal point:

FANUC 18M: X1004.7 or High speed SKIP I/O F122

Measurement program operation procedure:

O9724 parameter setup



O9810 Displacement protection program testing

O9801 Calibration of the length of the Z axis (OMP60 Length compensation)

O9802 Main shaft offset calibration (Dial gauge can be used to adjust the offset)

O9803 Calibration of the spherical radius (Calibration of the radius of the stylus ball)



Workpiece measuring program

Parameter setup: (Set up the parameters before calibration)

% O9724(SETTINGS)

#120=1(SELECT OPTIONS) → Setting up the cutter compensation model
(Please refer to the table below for the setup) .

M98P9723

G90G80G40

IF[#4008NE49]GOTO1

#3000=89(NO TOOL LENGTH ACTIVE) N1

IF[#4006EQ20]GOTO4

IF[#4006EQ70]GOTO4

#123=.05(INPOS ZONE MM)

#129=1

#119=5000(FAST FEED MM) → Speed setup for High speed feed (Default **5000**)

GOTO5

N4

#129=04

#123=.002(INPOS ZONE INCH)

#119=200(FAST FEED INCH) N5

IF[#506LE0]GOTO6

%

GOTO7

N6

#506=.5 → Withdraw volume setup (Default **0.5**)

N7

M99

IF[#506GT1]GOTO6

#120 Setup for the mode of cutter compensation			
		Controller models	
Tool compensation	Abnormal tolerable error (公差) display	Fanuc 10/11/15 M (Meldas)	Fanuc 0/6/18 M
Type A	Note and generate abnormal alarm	#120=1	#120=9
Type B	Note and generate abnormal alarm	#120=2	#120=10
Type C	Note and generate abnormal alarm	#120=3	#120=11
Type A	Note	#120=4	#120=13
Type C	Note	#120=5	#120=15
Type B	Note	#120=6	#120=14

Check the number of OFFSET cutter compensate sets:

If the number of cutter compensate sets is greater than 200, please turn on program O9723, change from #27=2000 to #27=10000, and change from #28=2200 to #28=11000. For any changes in numbers, such as changing from =2000 to=10000

```
O9723 ( REN * ACT * OFFSET )
#27 = 2000 ( L * GEOM * 10000 )
#28 = 2200 ( L * WEAR * 11000 )
#116 = # [ #27 * #4111 ]
IF [ #120 AND 3 EQ 1 ] GOTO 1
#116 = # [ #27 + #4111 ] + # [ #28 + #4111 ]
N1
M99
%
```

If the number of cutter compensation sets is greater than 200, turn on O9732 program, change from #27=2000 to #27=10000, change from #28=2200 to #28=11000, change from #29=2600 to #29=12000, and change from #30=2400 to #30=13000. For any changes in number, such as changing from =2000 to=10000,

```
O9732 ( REN * OFFSET * TYPE )
#27 = 2000 ( L * G-W ** 11000 )
#28 = 2200 ( L * WEAR * 11000 )
#29 = 2600 ( R * WEAR * 12000 )
#30 = 2400 ( L * GEOM * 13000 )
IF [ #23 EQ 1 ] GOTO 11
IF [ #120 AND 8 NE8 ] GOTO 6
```

Corresponding table for measurement output

	Terminal plane measurement	Groove / Convex ribs	Aperture / column	Outer and inner corner measurement	The fourth axis measurement	X/Y axis angle measurement
	G65 P9811	G65 P9812	G65P9843	G65 P9815 P9816	G65P9817/18	G65 P9814
#135	X axis location	X axis location	X axis location	X axis location		
#136	Y axis location	Y axis location	Y axis location	Y axis location		
#137	Z axis location					
#138	Size	Size	Size	Size		
#139				X Axis angle	Angle of the fourth axis	Angle
#140	X axis offset	X axis offset	X axis offset	X axis offset		
#141	Y axis offset	Y axis offset	Y axis offset	Y axis offset	Height offset	Height offset
#142	Z axis offset			Z axis offset	Angular offset	Angular offset
#143	Size offset	Size offset		Y axis offset angle		
#144				X axis offset angle		
#145	True position error	True position error	True position error	True position error		
#146	Metal condition	Metal condition	Metal condition			
#147	Direction indicator					
#148	Note on exceeding the tolerable error range					
#149	Probe error flag (0 to 2)					

Corresponding table for measurement output					
	PCD aperture / column measurement	Angular terminal plane measurement	Groove / concave rib of the angle measurement	Three-point measurement of the aperture	Featuring point distance measurement
	G65P9819	G65P9821	G65P9822	G65P9823	G65P9834
#135	X axis location	X axis location	X axis location	X axis location	X axis distance
#136	Y axis location	Y axis location	Y axis location	Y axis location	Y axis location
#137	PCD				Y axis location
#138	Dimensions	Dimensions	Dimensions	Dimensions	Location and distance
#139	Angle				Angle
#140	X axis offset	X axis offset	X axis offset	X axis offset	X axis offset
#141	Y axis offset	Y axis offset	Y axis offset	Y axis offset	Y axis offset
#142	PCD offset				Z axis offset
#143	Size offset	Size offset	Size offset	Size offset	Size offset
#144	Angular offset				Angular offset
#145	True position error	True position error	True position error	True position error	True position error
#146	Metal condition	Metal condition	Metal condition	Metal condition	Metal condition
#147	Hole number	Direction indicator			
#148	Note on exceeding the tolerable error range				
#149	Probe error flag (0 to 2)				

Measurement criteria input table			
Parameter input	Parameter definition	Example	Note
S1~S6	Work piece coordinate system compensation	G65 P9814 D30. S2	Setting up the work piece coordinate system G55
S101~S148	Outer work piece coordinate system compensation	G65 P9814 D30. S101	Setting up the work piece coordinate system G54.1 P1
T	Cutter abrasion compensation	G65 P9814 D30. T8. S2	Update cutter NO. 8 abrasion compensation
M	Tolerable error setup for position	G65 P9814 D30. M0.3 S2	Tolerable error for position ± 0.3
H	Tolerable error setup for dimension	G65 P9814 D30. H0.7 S2	Dimensional tolerable error ± 0.7
B	Tolerable error setup for angles	G65 P9814 D30. B5. S2	Angular tolerable error $\pm 5^\circ$
Q	Changing the idling quantity	G65 P9814 D30. S2. Q6	(Default 4mm)
R	Aperture/column offset measurement	G65 P9812 D30. R10. S2	(Default 5mm)
-R	Aperture/column offset measurement	G65 P9812 D30. R-10. S2	
U	Setting up the tolerable error for the dimensions	G65 P9814 D30.U2.	For the absence of work piece coordinate or cutter compensation
I	Distance from the second measurement point (X axis)	G65 P9815 X0. Y0. I10. J10. S1	For inner and the outer angular measurement
J	Measurement output	G65 P9816 X0. Y0. I10. J10. S1	
W1	Measurement output	G65 P9814 D30. S2. W1	The output data are not coded according to the measuring sequence.
W2	Distance from the second measurement point (Y axis)	G65 P9814 D30. S2. W2	The output data are not coded according to the measuring sequence.

Calibration programs: (Do calibration only after setting up the parameters.)

Program format	Example	Descriptions
<p>O9810 Displacement protection program</p> <p>X = Coordinate of the terminal point of the X axis</p> <p>Y = Coordinate of the terminal point of the Y axis</p> <p>Z = Coordinate of the terminal point of the Z axis</p>	<p>O0002; G90 G80 G40 G00</p> <p>G54 X0. Y0.;</p> <p>G43 H1 Z100.;</p> <p>G65 P9810 X-30. F30.;</p> <p>M30;</p>	<p>User defined codes</p> <p>Displacement protection shift X-30</p> <p>X-30 = Distance of X axial shift</p> <p>F = Speed of movement</p> <p>Contacting the probe while the machine table is moving will stop the movement.</p>
<p>P9801 Calibration of the length of the Z axis</p> <p>Z = Coordinate of the Z axis of the calibration plane</p> <p>T = Compensation number of the length of the probe</p>	<p>O0003; G90 G80 G40 G00; G54 X0. Y0.;</p> <p>G43 H1 Z100.;</p> <p>G65 P9810 Z5.F2000.;</p> <p>G65 P9801 Z0. T1.;</p> <p>M30;</p> <p>G65 P9810 Z100. F2000.;</p>	<p>User defined codes</p> <p>Move the displacement protection to 5mm above the calibration plane of the z axis.</p> <p>Calibration of the length of the Z axis</p> <p>Z0 = Z0 is the reference plane</p> <p>T1 = The calibrated length value is saved in Compensation No. 1</p>

<p>P9802 Main shaft offset calibration</p>	<p>O0004 ; G90 G80 G40 G00 ; G54 X0. Y0. ; G43 H1 Z100. ; G65 P9810 Z-5. F2000. ; G65 P9802 D40. ;</p>	<p>User defined codes Move displacement protection to -5mm of the Z plane; Calibrate the position of the center of the stylus; Diameter of the ring gauge D = 40mm Where it is saved after calibration #502 = X axis offset value #503 = Y axis offset value (adjusting the offset This program can be replaced by using a dial gauge for)</p>
	<p>G65 P9810 Z100. F2000. M30 ;</p>	
<p>Dial gauge for calibrating the main shaft offset.</p>	<p>P9016 For calibrating main shaft offset, a bore has to be made to find out the exact position of the coordinate. This coordinate is then used to calibrate the offset of the probe. (It will be easier and more convenient to use a dial gauge for adjusting the offset.) (If a dial gauge is used for adjusting the offset of the probe, #502 and #503 have to be set to 0) (Adjust the offset to 5μ or less)</p>	
<p>P9803 、 P9804 Spherical radius</p>	<p>O0005; G90 G80 G40 G00; G54 X0. Y0. ; G43 H1 Z100. ; M30 ; G65 P9804 D40. G65 P9810 Z100. F2000. ; G65 P9810 Z-5. F2000. ; G65</p>	<p>User defined codes Move the displacement protection to -5mm to the Z plane; Calibrating the spherical radius; Ring gauge D = 40 Where is it saved after the calibration: P9803 : #500 = X Spherical radius value P9804 :</p>
	<p>P9803 D40. ;</p>	<p>The values from #509 to #517 are measured at every 30° angle.</p>

Measurement programs:

<p>P9814 Circular aperture measurement</p> <p>D = Aperture diameter measurement</p> <p>S = Saving the center coordinate values (S1~S6 = G54~G59)</p> <p>T=Updating the cutter abrasion value</p> <p>H = Dimensional tolerable error</p> <p>R = Offset measurement</p> <p>M= Setting up the tolerable error for position</p>	<p>O0006 ; G90 G80 G40 G00 ; G54 X0. Y0. ; G43 H1 Z100. ; G65 P9810 Z-5. F2000. ; G65 P9814 D30. S1. ; G65 P9810 Z100. F2000. ; M30 ;</p>	<p>User defined codes</p> <p>Move the displacement protection to -5mm deep in the aperture. Aperture measurement; D30 = Aperture diameter; S1=Updating the work piece coordinate system G54</p>
<p>P9814 Column measurement</p>	<p>O0007 ; G90 G80 G40 G00 ; G54 X0. Y0. ; G43 H1 Z100. ; G65 P9810 Z15. F2000. ; G65 P9814 D30.Z-5.R10 ; G65 P9810 Z100.F2000. ; M30 ;</p>	<p>User defined codes</p> <p>Move the displacement protection to 15mm above the top of the column. Aperture measurement D30 = Column diameter R10 = Offset measurement (Default = 4mm)</p>

<p>P9812 Groove measurement</p> <p>M = Tolerable error setup for the position</p> <p>H = Dimensional tolerable error</p> <p>S = Saving the center coordinate values (S1~S6=G54~G59)</p> <p>R = Offset measurement</p> <p>T = Updating the cutter abrasion value</p>	<p>O0008 ; G90 G80 G40 G00 ; G54 X0. Y0. ; G43 H1 Z100. ; G65 P9810 Z-5. F2000. ;</p> <p>G65 P9812 X30. H0.1 ;</p> <p>G65 P9810 Z100. F2000. ;</p> <p>M30 ;</p>	<p>User defined codes</p> <p>Move the displacement protection to -5mm deep in the aperture.</p> <p>Groove measurement</p> <p>X30 = Measuring 30mm of the total length of the X axis</p> <p>H0.1 = Tolerable error ± 0.1 (Abnormal alarm goes off if the tolerable error range is exceeded.)</p> <p>Only one axis can be measured each time (the X axis or the Y axis)</p>
<p>P9812 Convex rib measurement</p>	<p>O0009 ; G90 G80 G40 G00 ; G54 X0. Y0. ; G43 H1 Z100. ; G65 P9810 Z15. F2000. ;</p> <p>G65 P9812 Y30. Z-5. T8. ;</p> <p>G65 P9810 Z100. F2000. ;</p> <p>M30 ;</p>	<p>User defined codes</p> <p>Move the displacement protection to 15mm above the column Measuring the convex rib</p> <p>Y30 = Measuring 30mm of the total length of the Y axis</p> <p>T8 = Updating the abrasion compensation of Cutter No. 8</p> <p>Only one axis can be measured each time (the X axis or the Y axis)</p>

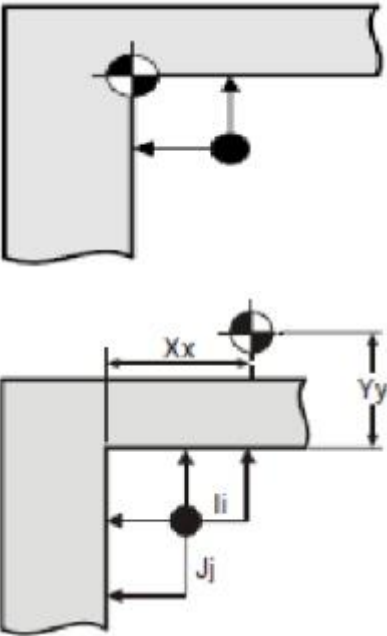
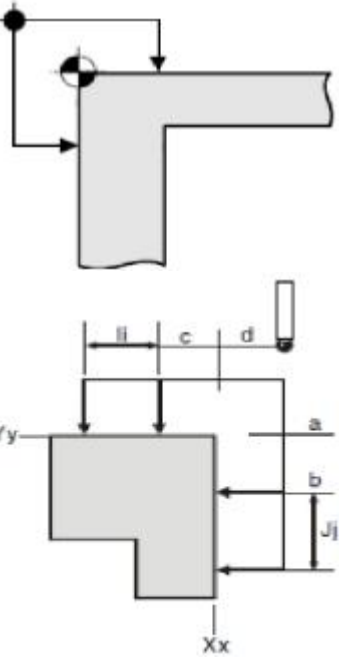
<p>P9815 Inner corner measurement</p> 	<p>O0012 ; G90 G80 G40 G00 ; G54 X20. Y-20. ; G43 H1 Z100. ; G65 P9810 Z-5. F2000. ; G65 P9815 X0. Y0. B5. S1 ; G65 P9810 Z100. F2000. ; M30 ;</p>	<p>User defined codes Move the displacement protection to -5mm of the measuring plane. Measuring the reference plane X0 and Y0 S1 = Updating G54's workpiece coordinate system. B5 = Angular tolerable error ± 5 J = Distance for measurement of the second point on the Y plane I = Distance for measurement of the second point on the X plane</p>
<p>P9816 Outer corner measurement</p> 	<p>O0013 ; G90 G80 G40 G00 ; G54 X-20. Y20. ; G43 H1 Z100. ; G65 P9810 Z-5. F2000. ; G65 P9816 X0. Y0. S2 ; G65 P9810 Z100. F2000. ; M30 ;</p>	<p>User defined codes Move the displacement protection to -5mm of the measuring plane. Measuring the reference plane X0 and Y0 S2 = Updating G55's work piece coordinate system</p>

<p>P9823 Three-point aperture measurement</p>	<p>Required parameters</p> <p>A: Angle of the first point B: Second point angle C: The third point angle Z: Measuring the depth D: Aperture diameter</p>	<p>Optional parameters</p> <p>H : Tolerable error of the aperture M : Tolerable error of position W : Measurement output S : Updating work piece coordinate T : Cutter abrasion compensation Q : Idling quantity R : Displacement measurement</p>
	<p>O0014 ; G90 G80 G40 G00 ; G54 X0. Y0. ; G43 H1 Z100. ; G65 P9810 Z-5. F2000. ; G65 P9823 A30. B180. C270. D50. S3. H0.01 W1 ; G65 P9810 Z100. F2000. ; M30 ;</p>	
<p>Example : G65 P9823 Aa Bb Cc Dd [Hh Mm Qq Rr Ss Tt Ww] ;</p>		

<p>P9819 PCD Aperture / column measuring</p>	<p>Required parameters C : The third point angle D : Aperture diameter K : Measuring the depth of the aperture Z : Measuring the depth of the column</p>	<p>Optional parameters A : Angle of the first point W : Measurement output H : Tolerable error of the aperture M : Tolerable error of position Q : Idling quantity R : Displacement measurement S : Updating work piece coordinate T : Cutter abrasion compensation B : Second point angle</p>
<p>O0015 ; G90 G80 G40 G00 ; G54 X0. Y0. ; G43 H1 Z100. ; G65 P9810 Z10. F2000. ; G65 P9819 B180. C270. D50. Z-5. S3. H0.01 W1 ; G65 P9810 Z100. F2000. ; M30 ;</p>		
<p>Example :</p> <p>PCD Aperture diameter measurement G65 P9819 Cc Dd Zz [Aa Bb Hh Mm Qq Rr Ss Tt Ww Ss] ; PCD Column measurement G65 P9819 Cc Dd Kk [Aa Bb Hh Mm Qq Rr Ss Tt Ww Ss] ;</p>		

<p>P9834 Feature point distance measurement (X & Y axial planes)</p>	<p>Required parameters X : X axial distance measurement Y : Y axial distance measurement D : Aperture diameter A : Angle of the first point</p>	<p>Optional parameters B : Second point angle H: Tolerable error of the aperture W : Measurement output S : Updating work piece coordinate T : Cutter abrasion compensation M : Tolerable error of position</p>
	<p>O0016 ; G90 G80 G40 G00 ; (1) G54 X0. Y0. ; (2) G43 H1 Z100. ; (3) G65 P9810 Z-5. F2000. ; (4) G65 P9814 D30. ; → First aperture measurement (5) G65 P9834 ; → P9834 Connected to the next (6) G65 P9810 Z100. F2000. ; (7) G65 P9810 X20. Y20. (8) G65 P9810 Z-5. F2000. ; (9) G65 P9814 D30. ; → Second aperture (10) G65 P9834 A45. D1. W1 ; →P9834 Entered the inspection criteria G65 P9810 Z100. M30 ;</p>	

<p>Measuring the distance between the border and the aperture</p>	<p>O0017 ; G90 G80 G40 G00 ; G54 X10. Y0. ; (1) G43 H1 Z100. ; (2) G65 P9810 Z-5. F2000. ; (3) G65 P9811 X0. ; → Measuring the border of X=0 (4) G65 P9834 ; →P9834 connected to the next measurement point (5) G65 P9810 Z10. F2000. ; (6) G65 P9810 X-20. (7) G65 P9810 Z-5. F2000. ; (8) G65 P9814 D30. ; → Aperture measurement (9) G65 P9834 X-20. W1 ; →P9834 Inputting the test criteria G65 P9810 Z100. M30 ;</p>
<p>Example :</p> <p>G65 P9834 Xx [Hh Mm Ss Tt Ww] ; G65 P9834 Yy [Aa Bb Hh Mm Ss Tt Uu Ww] ; G65 P9834 Xx Yy [Hh Mm Ss Tt Ww] ; G65 P9834 Aa Dd [Bb Hh Mm Ss Ww] ; G65 P9834 ; (There is no input of any test criteria)</p>	<p>If there is no input of any test criteria #135 → #130 #136 → #131 #137 → #132 #138 → #133 #139 → #134</p>

<p>P9834 Featuring point distance measuring (Z and axial gap)</p>	<p>Required parameters Z : Depth measurement Z : Depth measurement OR D : Displacement measurement (X&Y axes) A : Z axis measuring angles</p>	<p>Optional parameters B: Angular tolerable error H: Dimensional tolerable error W: Measurement output S: Work piece coordinate update T: Cutter abrasion compensation M: Tolerable error of position</p>
<p>Stepwise gap measurement</p>	<p>O0018 ; G90 G80 G40 G00 ; G43 H1 Z100. ; (1) G54 X10. Y0. ; (2) G65 P9810 Z20. F2000. ; (3) G65 P9811 Z0. ; → Measuring the position of the first point Z0 (4) G65 P9834 ; → P9834 connected to the next measurement point (5) G65 P9810 X-20. ; (6) G65 P9811 Z-5. ; (7) G65 P9834 H0.3 W1. ; →P9834 Inputting the test criteria G65 P9810 Z100. ; G65 P9810 Z100. M30 ;</p>	

<p>Slope gap measurement</p>	<p>O0019 ; G90 G80 G40 G00 ; G43 H1 Z100. ; (1) G54 X10. Y0. ; (2) G65 P9810 Z20. F2000. ; (3) G65 P9811 Z-5. ; → Measuring the position of the first point Z0 (4) G65 P9834 ; → P9834 connected to the next measuring point (5) G65 P9810 X20. ; (6) G65 P9811 Z-10. ; (7) G65 P9834 A-15. Z-5. ; →P9834 Inputting the test criteria G65 P9810 Z100 G65 P9810 Z100. M30 ;</p>
<p>Exemple</p> <p>G65 P9834 Xx [Hh Mm Ss Tt Ww] ;</p> <p>G65 P9834 Yy [Aa Bb Hh Mm Ss Tt Uu Ww] ;</p> <p>G65 P9834 Xx Yy [Hh Mm Ss Tt Ww] ;</p> <p>G65 P9834 Aa Dd [Bb Hh Mm Ss Ww] ;</p> <p>G65 P9834 ; (There is no input of any test criteria)</p>	<p>If there is no input of any test criteria</p> <p>#135 → #130</p> <p>#136 → #131</p> <p>#137 → #132</p> <p>#138 → #133</p> <p>#139 → #134</p>

<p>P9843 X Y axis angular measurement</p>	<p>Required criteria D : Displacement measurement X : Measuring displacement of the points Y : Measuring displacement of the points</p>	<p>Optional criteria A: Measuring the angles W: Measurement output B: Angular tolerable error</p>
<pre>O0020 ; G90 G80 G40 G00 ; G43 H1 Z100. ; G54 X0. Y0. ; G65 P9810 X30. Y50. F2000. ; G65 P9810 Z10. F2000. ; G65 P9843 Y30. D30. A45. F2000. G65 P9810 Z100. F3000. ; M30 ;</pre>		
<p>Example</p> <p>G65 P9843 Dd Xx [Aa Bb Ww] ;</p> <p>G65 P9834 Dd Yy [Aa Bb Ww] ;</p>	<p>Measuring results</p> <p>#139 = Actual angle</p> <p>#143 =</p> <p>#144 = Angular error</p>	

<p>P9821 Angular plane measurement</p>	<p>Required criteria D : Displacement A : Axial plane</p>	<p>Optional criteria H : Dimensional tolerable error M: Tolerable error of position Q: Idling quantity T: Cutter abrasion compensation W: Measurement output S: Work piece coordinate update</p>
	<p>O0020 ; G90 G80 G40 G00 ; (1) G43 H1 Z100. ; (2) G54 X10. Y0. ; (3) G65 P9810 Z-5. F2000. ; (4) G65 P9821 A45. D50. H0.5 S Z101. ; (5) G65 P9810 Z10. F2000. ; G65 P9810 Z10. M30 ;</p>	
<p>Example :</p> <p>G65 P9821 Ad Dd [Aa Bb Ww Qq] ;</p>		

<p>P9822 Groove / concave rib angular measurement</p>	<p>Required criteria A : Angle of axial plane D : Displacement Z : Depth measurement</p>	<p>Optional criteria H : Dimensional tolerable error M : Tolerable error of position S : Work piece coordinate system update Q : Idling quantity R : Measuring the offset value W : Measurement output T : Cutter abrasion compensation</p>
	<p>O0021 ; G90 G80 G40 G00 ; (1) G43 H1 Z100. ; (2) G54 X10. Y0. ; (3) G65 P9810 Z10. F2000. ; (4) G65 P9822 A45. D50. H0.5 M0.2 T8 Z-5. ; (5) G65 P9810 Z10. F2000. ; G65 P9810 Z100. M30 ;</p>	
<p>Example :</p> <p>G65 P9821 Ad Dd Zz [Hh Mm Ss Tt Rr Ww Qq] ;</p> <p>R : Default value 5 mm</p>		

<p>P9817 Measurement of the fourth axis (X axis)</p>	<p>Required criteria X : Distance measurement (X axis) Z : Depth measurement</p>	<p>Optional criteria B : Angular tolerable error (45⁰) Q : Idling quantity S : Work piece coordinate system update W : Measurement output</p>
	<p>O0022 ; G90 G80 G40 G00 ; (1) G43 H1 Z100. ; (2) G54 X10. Y0. ; (3) G65 P9810 Z10. F2000. ; (4) G65 P9817 X50. Z20. B0.5 S1 ; (5) G65 P9810 Z10. F2000. ; G65 P9810 Z100. M30 ;</p>	
<p>Example : G65 P9821 Xx Zz [Bb Ss Ww Qq] ; Q : Default value 10 mm</p>	<p>#143 : The relative error of the first and the second points of the Z axis #144 : Angle of the Z axis #139 : Position measurement of the fourth axis</p>	

<p>P9818 Measurement of the fourth axis (Y axis)</p>	<p>Required criteria X: Distance measurement (X axis) Z: Depth measurement</p>	<p>Optional criteria B: Angular tolerable error (45°) Q: Idling quantity W: Output measurement S: Work piece coordinate system update</p>
	<p>O0023 ; G90 G80 G40 G00 ; (1) G43 H1 Z100. ; (2) G54 X10. Y0. ; (3) G65 P9810 Z10. F2000. ; (4) G65 P9817 Y50. Z20. B0.5 S1 ; (5) G65 P9810 Z10. F2000. ; G65 P9810 Z100. M30 ;</p>	
<p>Example : G65 P9821 Yy Zz [Bb Ss Ww Qq] ; Q : Default value 10 mm</p>	<p>#143 : The relative error of the first and the second points of the Z axis #144 : Angle of the Z axis #139 : Position measurement of the fourth axis</p>	

