

**SHARP**

---

**OD-1340SE  
Cylindrical Grinder  
Parts List**

**Sharp Industries, Inc.**

## 目 錄 (Catalogue)

1	砂輪頭 Wheelhead	AB010100	砂輪頭 Wheelhead	01-1~ 01-3
		PB130120	砂輪頭 (選購) Interal grinding att ( OPT )	01-4~ 01-5
		PB010120	砂輪頭主軸(軸承式) Spindle (I)	01-6~ 01-7
		AB011905	5"軸承式砂輪套 Flange(5")	01-8~ 01-9
2	平衡台 Balancing stand	PB010320	平衡台 Balancing stand	02-1~ 02-2
3	主輪台 Workhead	PB020120	主輪台 Workhead	03-1~ 03-3
		PB020220	主輪台主軸(I) Workhead(I)	03-4~ 03-6
		PB020320	主輪台主軸 (II) Workhead spingle (II)	03-7~ 03-09
		PB020400	夾頭背板 (選購) Chuck back plate ( OPT )	03-10~ 03-11
4	尾座 Talstock	PB030120	尾座 Talstock	04-1~ 04-3
		PB030220	尾座固定式微調型砂輪修整器 Wheel dresser	04-4~ 04-5
		PB030320	油壓尾座 Hydraulic tall stock	04-6~ 04-7
5	工作滑板 Table	PB060120	工作滑板 Table	05-1~ 05-3
		PB060220	工作滑板 (II) Table (II)	05-4~ 05-6
		PB060320	工作滑板 (III) Table (III)	05-7~ 05-8
		AN960100	工作滑板 Table	05-9~ 05-11
6	齒輪座 Rack seat	PB060420	齒輪座 Rack seat	06-1~ 06-3
7	油壓開關 Hydraulic speed control unit	PB060520	油壓開關 Hydraulic speed control unit	07-1~ 07-2
8	本台 Base	PB070120	本台 Base	08-1~ 08-3
		AN970100	本台 Base	08-4~ 08-6



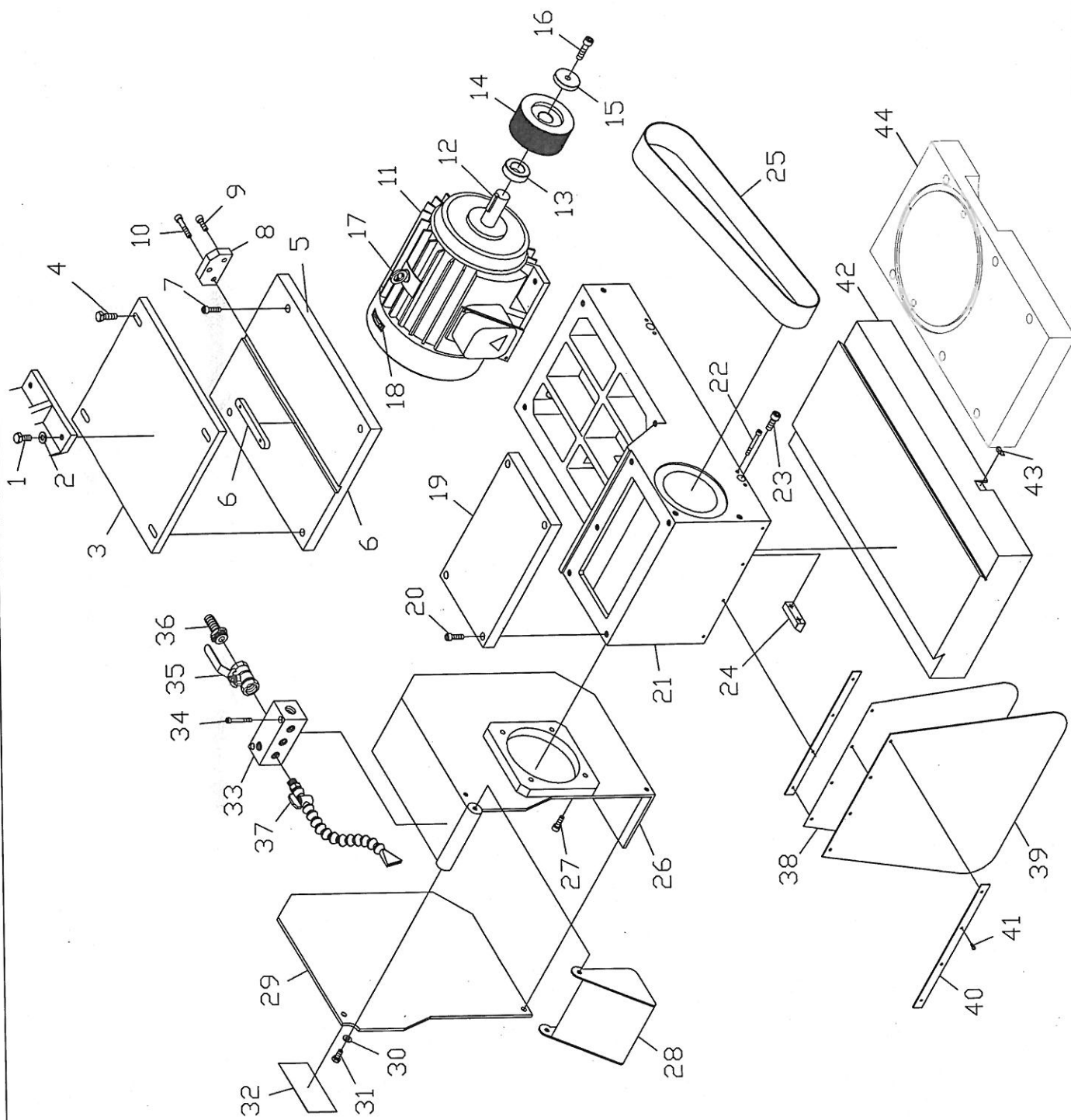

Sharp Industries, Inc.	圖名 (NAME) 砂輪頭 Wheelhead	核准 (APPROVE) 林榮涼	日期 (DATE) 2007.11.27	圖號 (NUMBER) AB010100
------------------------	----------------------------	---------------------	-------------------------	-------------------------

圖號(NUMBER):	AB010100
圖名(DRAWING):	砂輪頭 WHEELHEAD
日期 DATE):	2007.11.27
頁數(PAGE):	2-1

NO.	件號/Parts No.	件名	Description	Remarks	Qty.
1.		外六角螺絲	Hexagon screw	M10 × 1.5 × 25L	4
2.		彈簧墊圈	Spring washer	φ 10	4
3.	KB018603	馬達固定板	Motor bracket		1
4.		外六角螺絲	Hexagon screw	M10 × 1.5 × 35L	4
5.	KB018500	砂輪頭後蓋板	Wheelhead rear cover		1
6.	KB018706	固定鍵	Fixsd key	16 × 11 × 120L	1
7.		內六角沉頭螺絲	Socket screw	M8 × 1.25 × 30L	4
8.	KB018809	調整片	Adjusting plate		1
9.		內六角沉頭螺絲	Socket screw	M8 × 1.25 × 25L	2
10.		內六角沉頭螺絲	Socket screw	M8 × 1.25 × 30L	1
11.		交流馬達(臥式)	Spindle motor	5HP · 4P	1
		交流馬達(臥式)	Spindle motor	7.5HP · 4P	1
12.		雙頭圓鍵	Grove key	8 × 7 × 40L	1
13.	KB014702	間隔環	Spacer	D50*L19	1
14.	KC014702	馬達皮帶輪	Motor pulley	7.5HP	1
15.	KB014908	皮帶輪鎖緊墊圈	Clamping washer		1
16.		內六角沉頭螺絲	Socket screw	M10 × 1.5 × 40L	1
17.		吊勾螺絲	Hanger screw	M8 × 1.25	1
18.	KB162007	旋轉方向指標銘牌	Direction tag		1
19.	KB013103	砂輪頭前蓋板	Wheelhead top cover		1
20.		內六角沉頭螺絲	Socket screw	M8 × 1.25 × 30L	4
21.	KC010100	砂輪頭(軸受式)	Wheel head	(G32P-babbitt bearing)	1
	KB010100	砂輪頭(軸承式)	Wheel head	(G32P-bearing)	1
	KC012906	砂輪頭(加高型)	Wheel head	(G38P-babbitt bearing)	1
	KB019500	砂輪頭(加高型)	Wheel head	(G38P.G45P.G50P.G60P-bearing)	1
22.		內六角沉頭螺絲	Socket screw	M6 × 1 × 55L	4
23.		內六角沉頭螺絲	Socket screw	M10 × 1.5 × 30L	2
24.	KB014403	砂輪頭固定塊	Wheelhead plunger		2
25.	SB080120	小V平皮帶	V Belt	SPZ-1275	4
26.	KF014104	砂輪護罩	Wheel guard (D405)	(D405)	1
	KF013309	砂輪護罩	Wheel guard (D455)	(455)	1
	KF013608	砂輪護罩	Wheel guard (D510)	(510)	1
27.		內六角沉頭螺絲	Socket screw	M8 × 1.25 × 25L	4



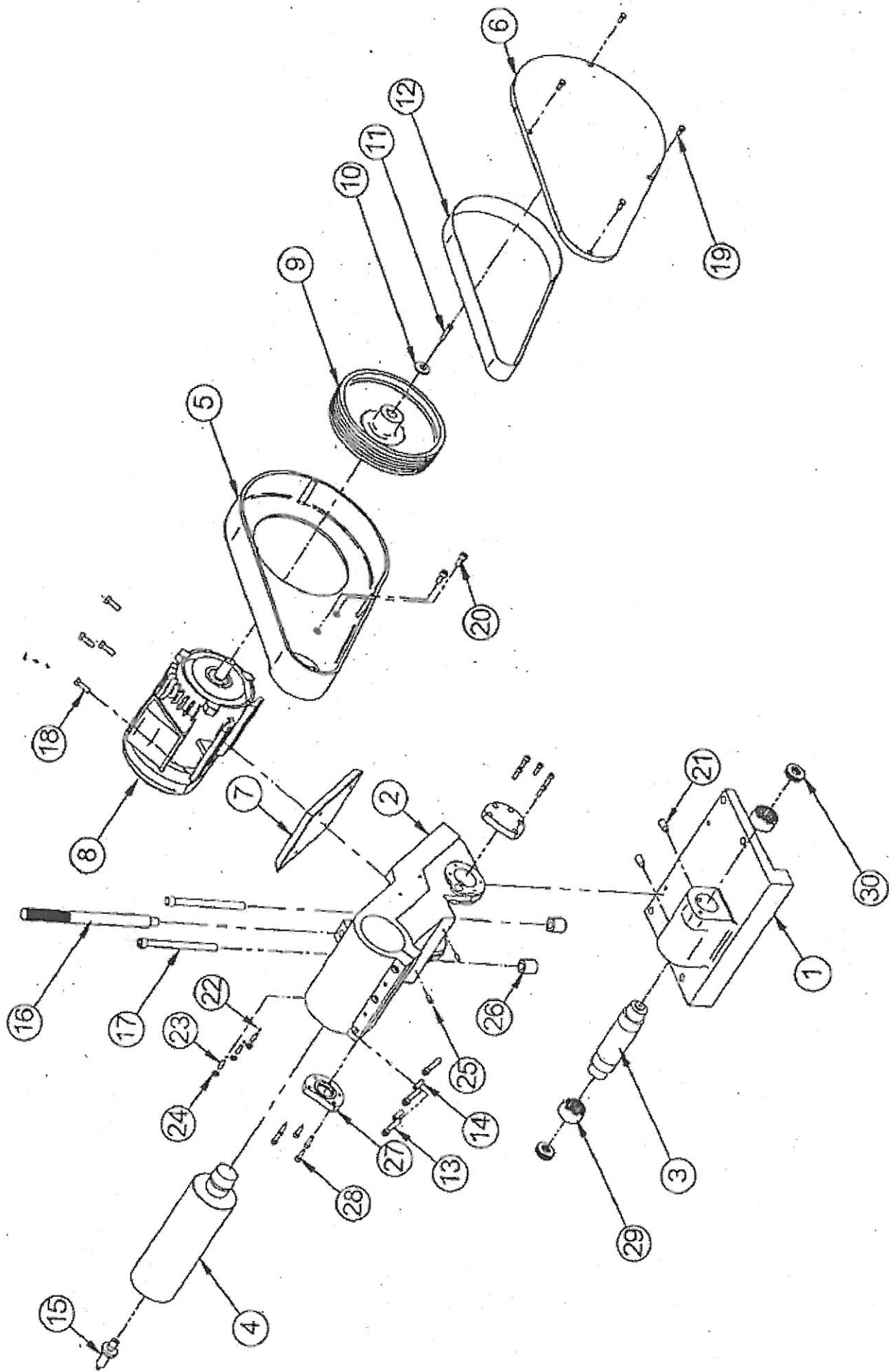

圖號(NUMBER):	PB130120
圖名(DRAWING):	內孔研磨(選購)
	INTERNAL GRINDING ATT (OPT)
日期 DATE):	2003.06.09
頁數(PAGE):	1-1

NO.	件號/Parts No.	件名	Description	Remarks	Qty.
1.	KB133100	砂輪頭上蓋	Wheelhead top cover for I.D.		1
2.	KB133007	內圓磨本體	I.D.base		1
3.	KB133416	本體固定軸	Fixed arbor for I.D.		1
4.	KB132707	內圓磨主軸	I.D.spindle		1
5.	KB133203	皮帶護罩	Belt cover		1
6.	KB133306	皮帶護罩蓋	Belt guard cover		1
7.	KB132006	馬達固定板	Motor fixed plate		1
8.		馬達	AC Motor	1.5HP	1
9.	KB133708	馬達皮帶輪	Motor pulley		1
10.	KB132202	墊圈	Washer		1
11.		平頭六角孔螺絲	Flat Socket screw	M6x35L	1
12.		平皮帶	Flat belt	1325	1
13.		沉頭內六角螺絲	Socket screw	M8x50L	3
14.		固定螺絲	Fixed screw	M8x30L	2
15.	KB137001	接桿(一)	I.D. shaft (1)		1
	KB137104	接桿(二)	I.D. shaft (2)		1
	KB137207	接桿(三)	I.D. shaft (3)		1
16.	KB132408	握柄	Handle		1
17.		六角螺紋	Hexagon screw	M12x1.75x1	2
18.		六角螺絲	Socket screw	M8x25L	4
19.		外六角頭螺帽	Hesd screw	M6x15L	4
20.		沉頭內六角螺絲	Socket screw	M8x20L	2
21.	KB130406	固定螺絲	Lock screw		2
22.		銅墊塊	Bronze block	φ 5	3
23.		固定螺絲	Fixed screw	M6x15L	3
24.		六角頭螺絲	Head nut	M6x1	3
25.		固定螺絲	Fixed screw	M6x15L	2
26.	KB131902	調整螺椿	Adjusting stake		2
27.	KB1337300	軸承固定蓋	Bearing fixsd cover		2
28.		沉頭六角螺絲	Socket screw	M6x20L	10
29.		滾針軸承	Needle bearing	TA3525	2
30.		滾珠軸承	Needle roller bearing	51104	2



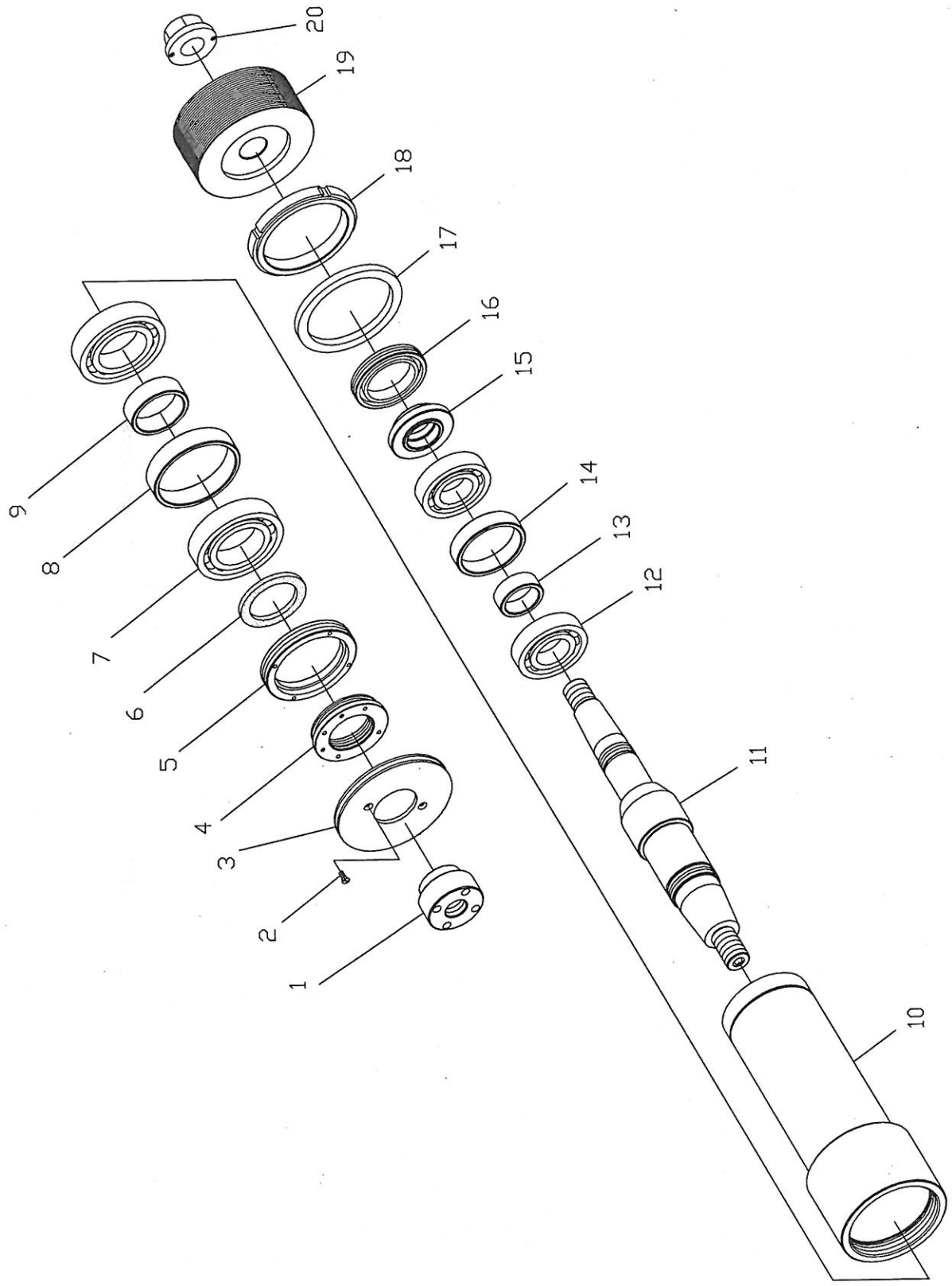

Sharp Industries, Inc.	圖名 (NAME)	日期 (DATE)	圖號 (NUMBER)
	砂輪頭主軸 (軸承式) Spindle (I)	2004.07.13	PB010120
	核准 (APPROVE)		
	沈世傑		



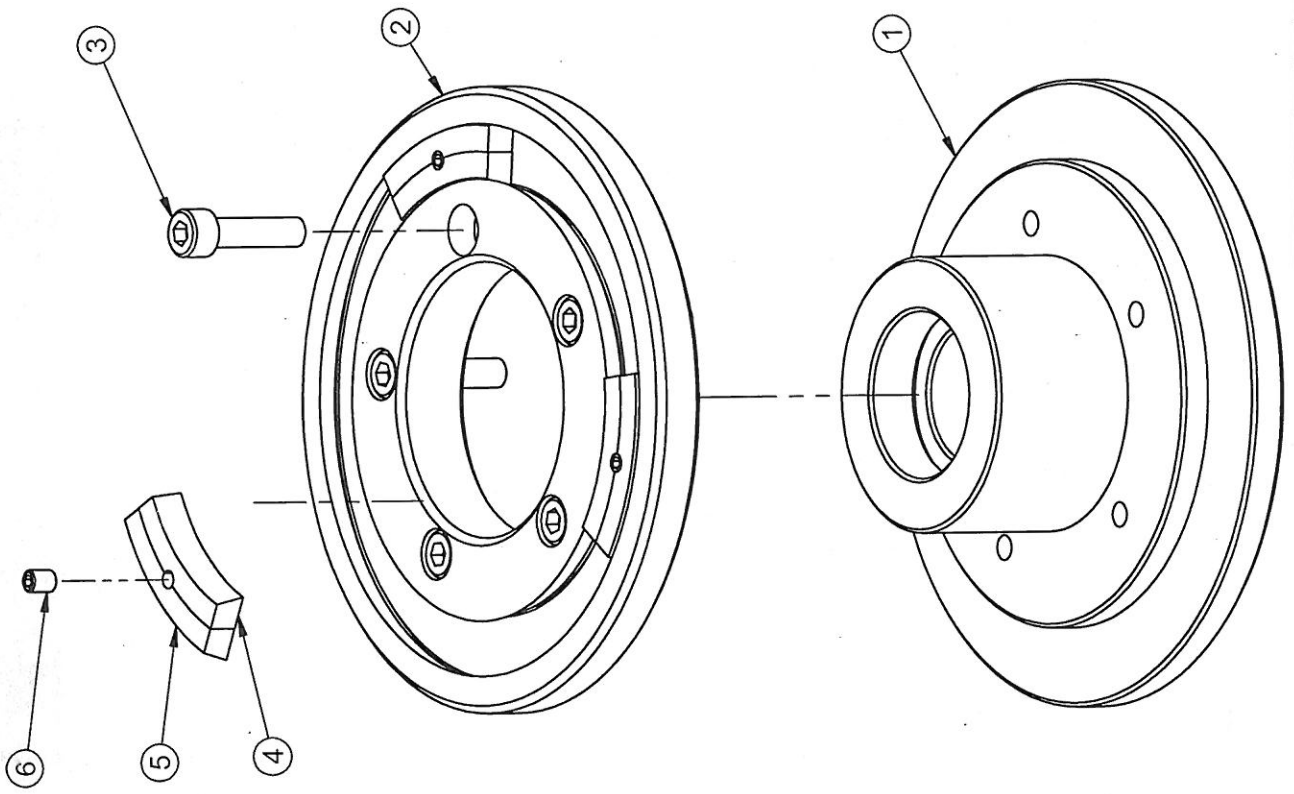

Sharp Industries, Inc.	圖名 (NAME)	5" 軸承式砂輪套(選購) Flange 5" (OPT)	核准 (APP) 沈世傑	日期 (DATE) 2004/9/18	圖號 (NUMBER) AB011905
------------------------	--------------	----------------------------------	-----------------	------------------------	-------------------------

圖號 (NUMBER)	AB011905
圖名 (DRAWING)	5" 軸承式砂輪套(選購)
	Flange(5"KOPT)
日期 (DATE)	2004/9/18
頁數 (PAGE)	1-1

NO.	Parts No.	件名	Description	Remarks	Qty.
1	KB011905	砂輪套	Flange		1
2	KB012009	砂輪套蓋	Wheel pressed plate		1
3	SD011565	沉頭內六角螺絲	HEX. SOCKET SCREW	M8X1.25X30L	5
4	KB012205	平衡片(二)	Balancing block		3
5	KB012102	平衡片(一)	Balancing block		3
6	SD030630	固定螺絲	FIXED SCREW	M6X1X8L	3

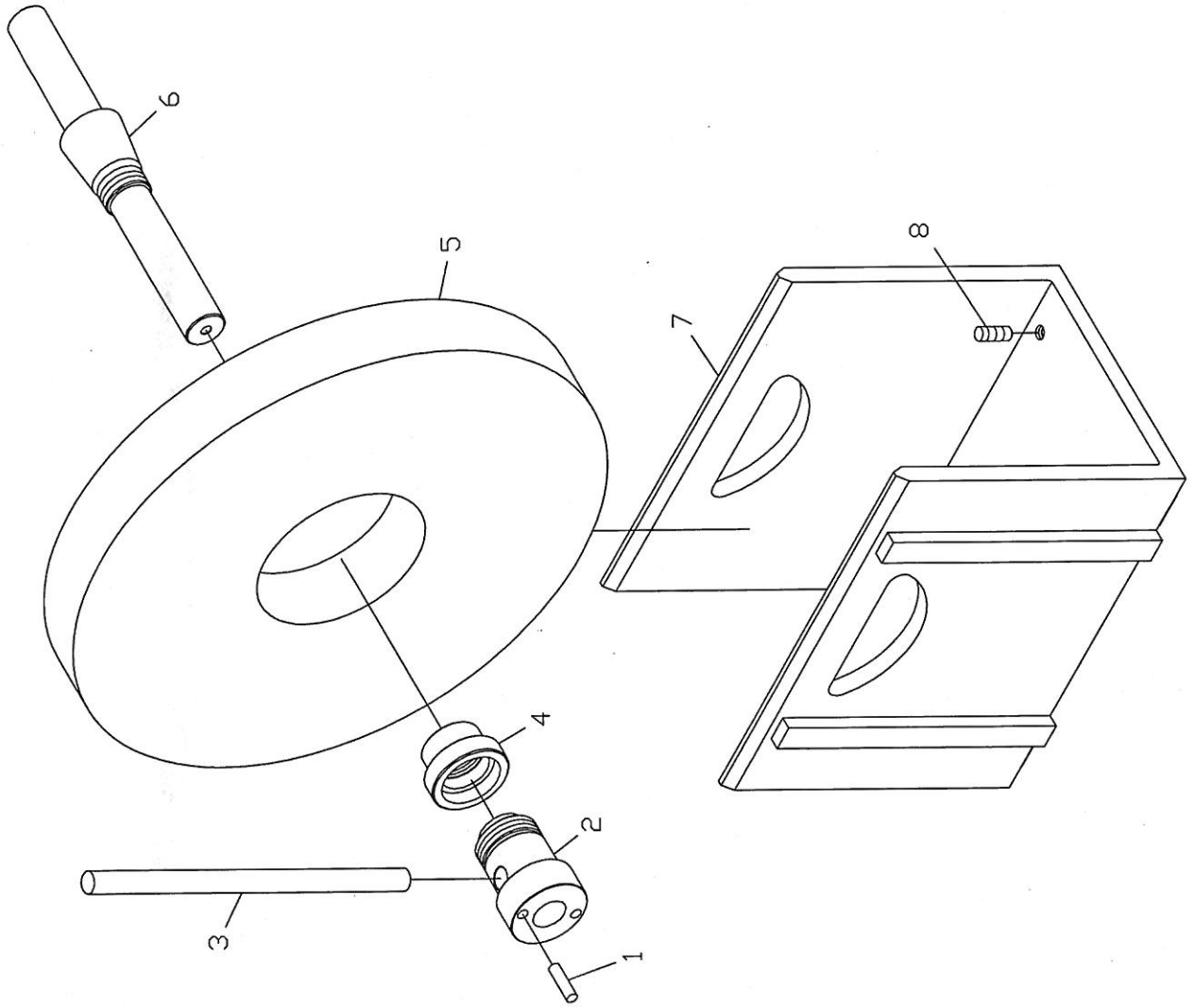

Sharp Industries, Inc.	圖名 (NAME) 平衡台 Balancing stand	核准 (APPROVE) 沈世傑	日期 (DATE) 2003.05.23	圖號 (NUMBER) PB010320
------------------------	----------------------------------	---------------------	-------------------------	-------------------------



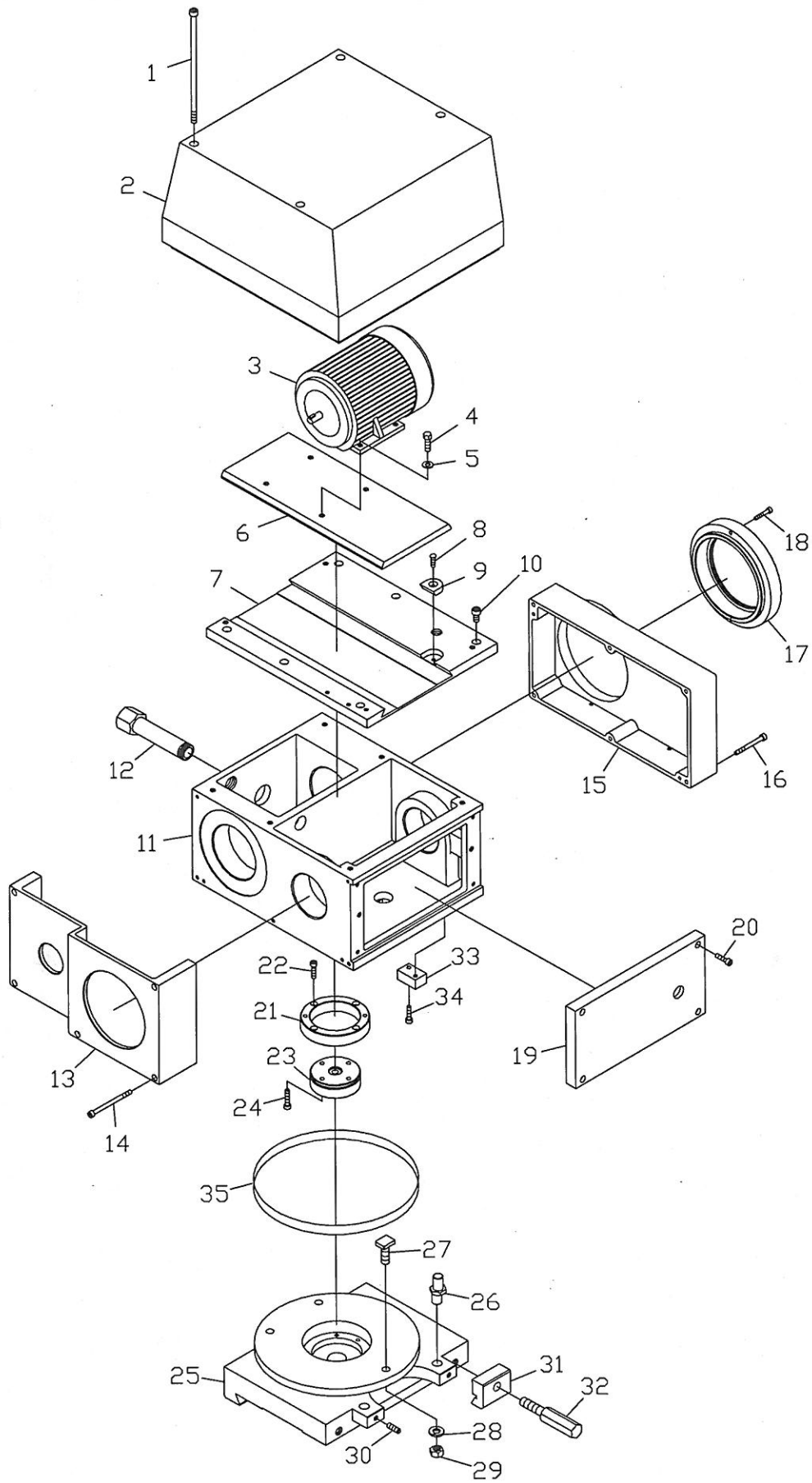

圖號 (NUMBER)	圖號 (NUMBER)
日期 (DATE)	日期 (DATE)
核准 (APPROVE)	核准 (APPROVE)
沈世傑	沈世傑
圖名 (NAME)	圖名 (NAME)
主輪台 Workhead	主輪台 Workhead
Sharp Industries, Inc.	

圖號(NUMBER):	PB020120
圖名(DRAWING):	主輪台
	WORKHEAD
日期 DATE):	2007.11.27
頁數(PAGE):	1-2

NO.	件號/Parts No.	件名	Description	Remarks	Qty.
1.		內六角螺絲	Socket screw	M8×220L	4
2.	KG027300	馬達護罩	Motor cover		1
3.		變頻馬達	Motor	2HP・4P	1
4.		外六角螺絲	Hexagon screw	M8×25L	4
5.		彈簧墊圈	Spring washer	φ 8	4
6.	KB029405	馬達固定板	Motor bracket		1
7.	KB029302	上蓋板	Top cover		1
8.		皿頭螺絲	Flat head screw	M6×15L	1
9.	KB029508	馬達板壓塊	Fixed block		1
10.		內六角螺絲	Socket screw	M8×10L	4
11.	KB020107	主輪台	Motor housing		1
12.	KB027702	電線管	Wire tube		1
13.	KB024400	左側蓋	Side cover(L)		1
14.		內六角螺絲	Socket screw	M6×85L	5
15.	KD023409	右側蓋	Side cover(R)		1
16.		內六角螺絲	Socket screw	M6×60L	6
17.	KB024307	防塵護罩	Front cover		1
18.		內六角螺絲	Socket screw	M5×30L	4
19.	KB024008	前蓋	Front cover		1
20.		內六角螺絲	Socket screw	M6×25L	4
21.	KB020406	支軸	Support seat		1
22.		內六角螺絲	Socket screw	M6×25L	4
23.	KB020303	旋轉軸	Turret seat		1
24.		內六角螺絲	Socket screw	M6×30L	4
25.	KN020200	旋轉座	Turret base	(G32P)	1
	KN020107	旋轉座(加高型)	Turret base	(G38P)	1
	KJ571600	旋轉座	Turret base	(G45P)	1
	KN321200	旋轉座	Turret base	(G50P)	1
	KN620200	旋轉座	Turret base	(G60P)	1
26.	KB020901	偏心桿	Eccentric lever		2
27.	KB020509	固定螺絲	Set bolt		3
28.		彈簧墊圈	Spring washer	φ 12	3
29.		六角螺帽	Hexagon nut	M12	3
30.		無頭螺絲	Headless screw	M8×12L	2





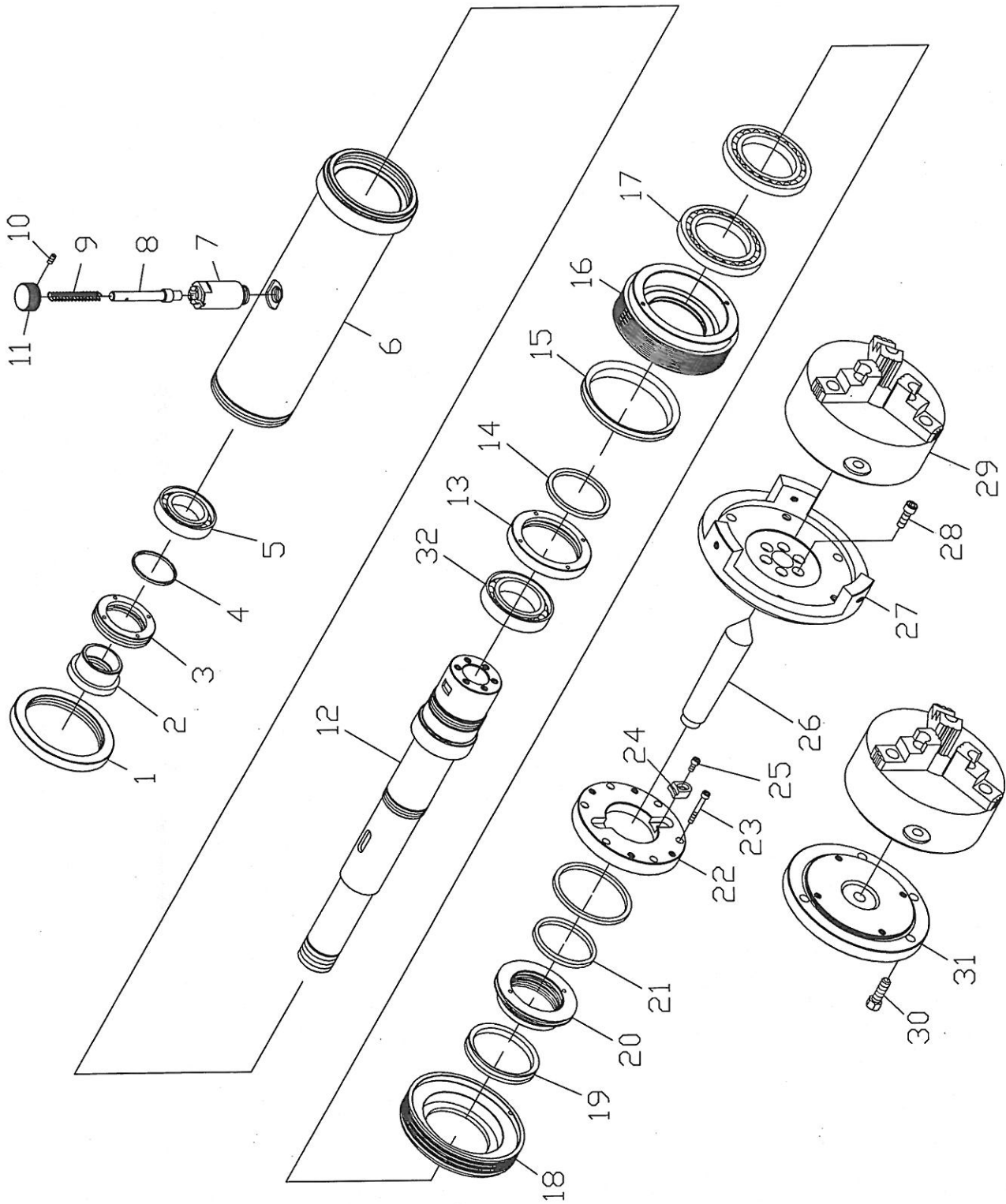

Sharp Industries, Inc.	圖名 (NAME)	核准 (APPROVE)	日期 (DATE)	圖號 (NUMBER)
	DRAWING	NAME	DATE	PARTNO

圖號(NUMBER):	PB020220
圖名(DRAWING):	主輪台主軸 - I
	WORKHEAD
日期 DATE):	2004.07.22
頁數(PAGE):	1-2

NO.	件號/Parts No.	件名	Description	Remarks	Qty.
1.		鎖緊螺帽	Lock nut	M120x2	1
2.	KB022202	鎖緊螺帽	Lock nut		1
3.		防塵螺帽	Dust-Proof nut	M55x1.5	1
4.		O型圈	O-Ring	G70	1
5.		滾柱軸承	Angular contact ball bearing	32011	1
6.	KN020901	主軸套筒	Graduated circle		1
7.	KB024606	固定栓座	Plunger		1
8.	KB024802	固定栓	Fixed bolt		1
9.	KB024709	彈簧	Spring		1
10.		平行栓	Pin	$\phi$ 3x20L	1
11.	KB024905	固定栓鈕	Cotter		1
12.	KN020602	主軸(MT4)	Spindle housing (MT4)		1
	KN020705	主軸(MT5)	Spindle housing (MT5)		1
	KN020808	主軸(5C)	Spindle housing (5C)		1
13.	KN021500	防塵螺帽	Dust-Proof nut		1
14.		O型圈	Asbestos ring	G70	1
15.		V型油封	Oil seal	V95	1
16.	KN021407	鎖緊螺帽	Flat pulley		1
17.		斜角滾珠軸承	Ball bearing	16015	2
18.	KN021201	內間隔環	Dust-proof bushing		1
19.		V型油封	Oil seal	V-95S	1
20.	KC026206	前防塵螺帽	Front dust-proof		1
21.		防塵棉	Asbestos ring	5x233L	1
22.	KN021108	帶動盤	Clutch		1
23.		內六角螺絲	Socket screw	M5x30L	6
24.	KC026608	主軸離合器	Clutch		2
25.		內六角螺絲	Socket screw	M5x12L	2
26.		頂針	Dead center	MT4	1
27.	KN021706	三爪夾頭背板(6")	Adjustable back plate(6")		1
	KN022109	三爪夾頭背板(7")	Adjustable back plate(7")		1
	KN022006	三爪夾頭背板(8")	Adjustable back plate(8")		1
	KN022501	三爪夾頭背板(9")	Adjustable back plate(9")		1
28.		頂針	Socket screw	M8x25L	6





圖號(NUMBER):	PB020320
圖名(DRAWING):	主輪台主軸-II
	WORKHEAD SPINDLE-II
日期 DATE):	2003.06.05
頁數(PAGE):	2-1

NO.	件號/Parts No.	件名	Description	Remarks	Qty.
1.		雙圓頭鍵	Groove key	6x6x25L	1
2.	KF020200	馬達皮帶輪	Motor pulley		1
3.	KB510404	墊圈	Washer		1
4.		皿頭螺絲	Flat head screw	M6x25L	1
5.		六角螺帽	Hexagon nut	M16	1
6.	KB029704	偏心軸	Eccentric bushing		1
7.	KB029900	間隔環	Spacer		1
8.		深溝滾珠軸承	Angular contact ball bearing	6004	2
9.	KB029601	支架	Supporting stand		1
10.		內六角螺絲	Socket screw	M6x30L	2
11.	KB029807	平皮帶輪	Flat belt		1
12.	KB510105	鎖緊螺帽	Lock nut		1
13.	KB029209	平皮帶輪	Flat belt		1
14.	KB023904	鎖緊螺帽	Lock nut		1
15.		齒型平皮帶	Timing belt	J240	1
16.		齒型平皮帶	Timing belt	J280	1
17.		銅條	Bronze bar	φ 6x8L	2
18.		無頭螺絲	Headless screw	M8x25L	4
19.		齒型平皮帶	Timing belt	J270	1
20.	KB022903	帶動片	Driving block		1
21.		內六角螺絲	Socket screw	M8x35L	1
22.	KB023007	帶動桿	Driving rod		1
23.		O型圈	O-Ring	P25	1
24.	KB023502	後防塵螺帽	Dust-Proof nut		1
25.		自動對位滾珠軸承	Positioning bearing	3205BT(IMK3205)	2
26.	KB023100	傳動軸	Transmission shaft		1
27.		雙圓頭鍵	Groove key	6x6x20L	1
28.		雙圓頭鍵	Groove key	4x4x16L	1
29.	KB023203	偏心套筒	Eccentric sleeve		1
30.		O型圈	O-Ring	AS130	1
31.	KB023409	前防塵螺帽	Dust-Proof nut		1
32.	KB023306	鎖緊螺帽	Lock nut		1
33.	KB023605	小平皮帶輪	Pulley		1



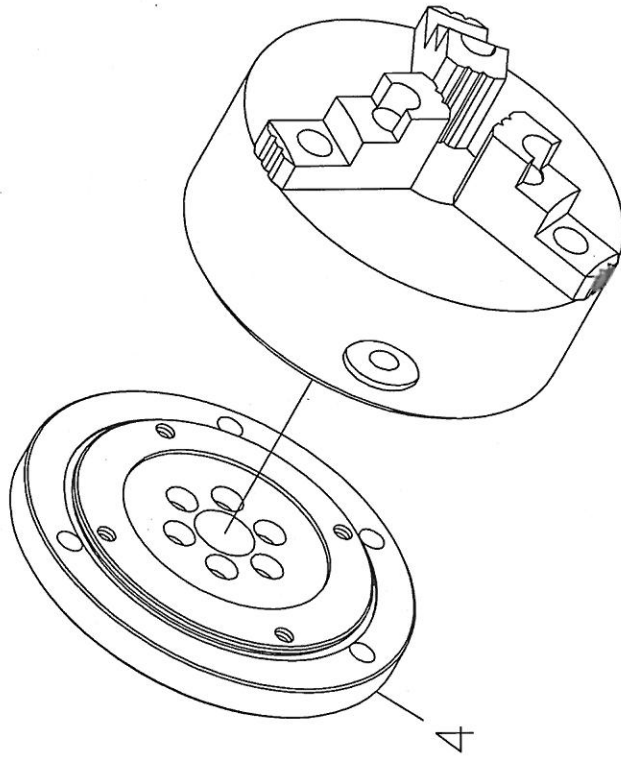
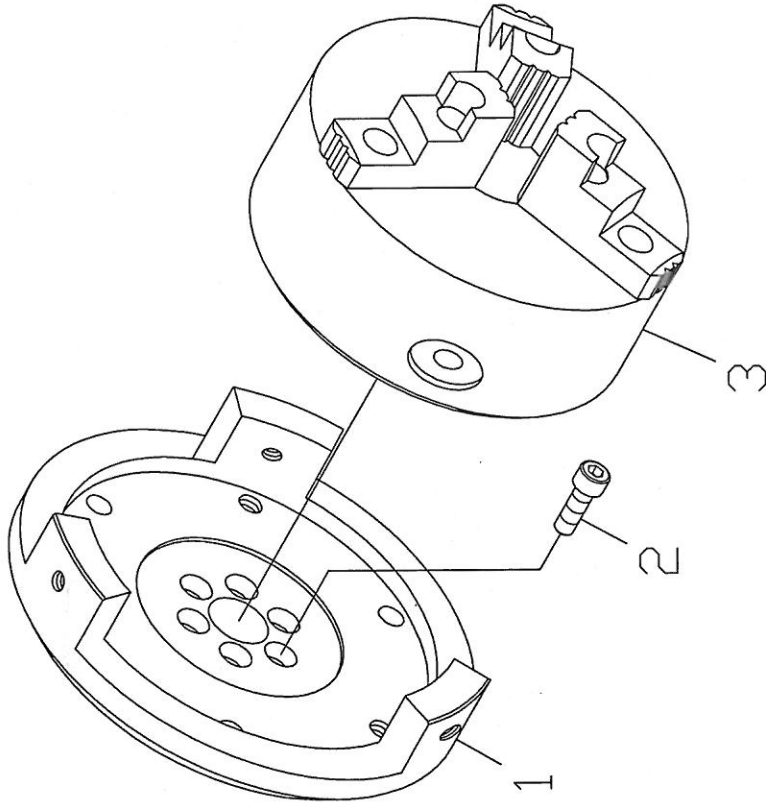

Sharp Industries, Inc.

圖名 (NAME)  
DRAWING

核准 (APPROVE)  
NAME

日期 (DATE)  
DATE

圖號 (NUMBER)  
PARTNO





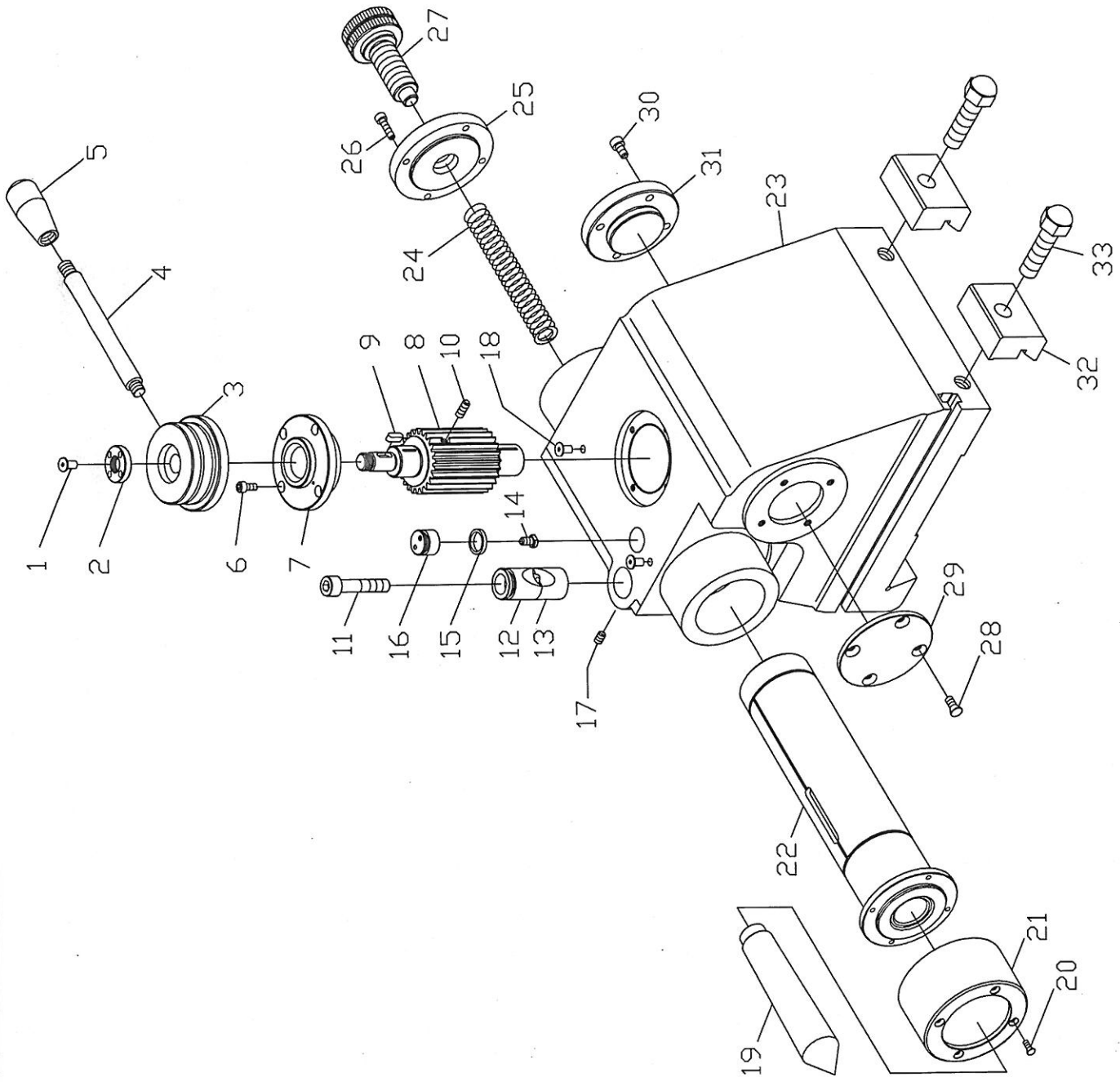

Sharp Industries, Inc.	圖名 (NAME) 尾座 Talstock	核准 (APPROVE) 沈世傑	日期 (DATE) 2004.07.12	圖號 (NUMBER) PB030120
------------------------	--------------------------	---------------------	-------------------------	-------------------------

圖號(NUMBER):	PB030120
圖名(DRAWING):	尾座
	TAILSTOCK
日期 DATE):	2007.11.27
頁數(PAGE):	2-1

NO.	件號/Parts No.	件名	Description	Remarks	Qty.
1.		油珠	Oil ball	1/4"	1
2.	KB031703	鎖緊螺帽	Lock nut		1
3.	KB031507	固定旋鈕	Handle boss		1
4.	KB031600	把手	Handle		1
5.		塑膠珠	Plastic knob	M10×1.5	1
6.		內六角螺絲	Socket screw	M6×10L	1
7.	KB031404	固定塊	Fixed cover		1
8.	KB031301	齒軸	Gear shaft		1
9.		雙圓頭鍵	Groove key	5×5×14L	1
10.		無頭螺絲	Headless screw	M6×16L	4
11.		內六角螺絲	Socket screw	M10×50L	1
12.	KB031002	上固定塊	Upper plunger		1
13.	KB030908	下固定塊	Lowler plunger		1
14.	KB030702	支持塊	Supporting seat		1
15.		O型圈	O-Ring	P16	1
16.	KB030805	固定軸	Fixed block		1
17.		無頭螺絲	Headless screw	M6×8L	1
18.		油珠	Oil ball	1/4"	2
19.		頂針	Dead center	MT4	1
20.		平頭螺絲	Flat head screw	M4×8L	4
21.	KD030609	前防塵蓋	Front Dust-Proof cover		1
22.	KD030908	滑筒	Sleeve	(MT4-25 mm)	1
	KD030506	滑筒	Sleeve	(MT5-25mm)	1
	KD031507	滑筒	Sleeve	(MT4-50mm)	1
	KD031002	滑筒	Sleeve	(MT5-50mm)	1
23.	KN030104	尾座	Tail stock	(G32P)	1
	KN030403	尾座(加高型)	Tail stock	(G38P)	1
	KJ571710	尾座	Tail stock	(G45P)	1
	KN330100	尾座	Tail stock	(G50P)	1
	KN630100	尾座	Tail stock	(G60P)	1
24.	KB030403	彈簧	Spring		1
25.	KD030702	後防塵蓋(一)	Supporting seat(1)		1
26.		內六角螺絲	Socket screw	M5×16L	4
27.	KB030609	調整旋鈕	Adjusting knob		1



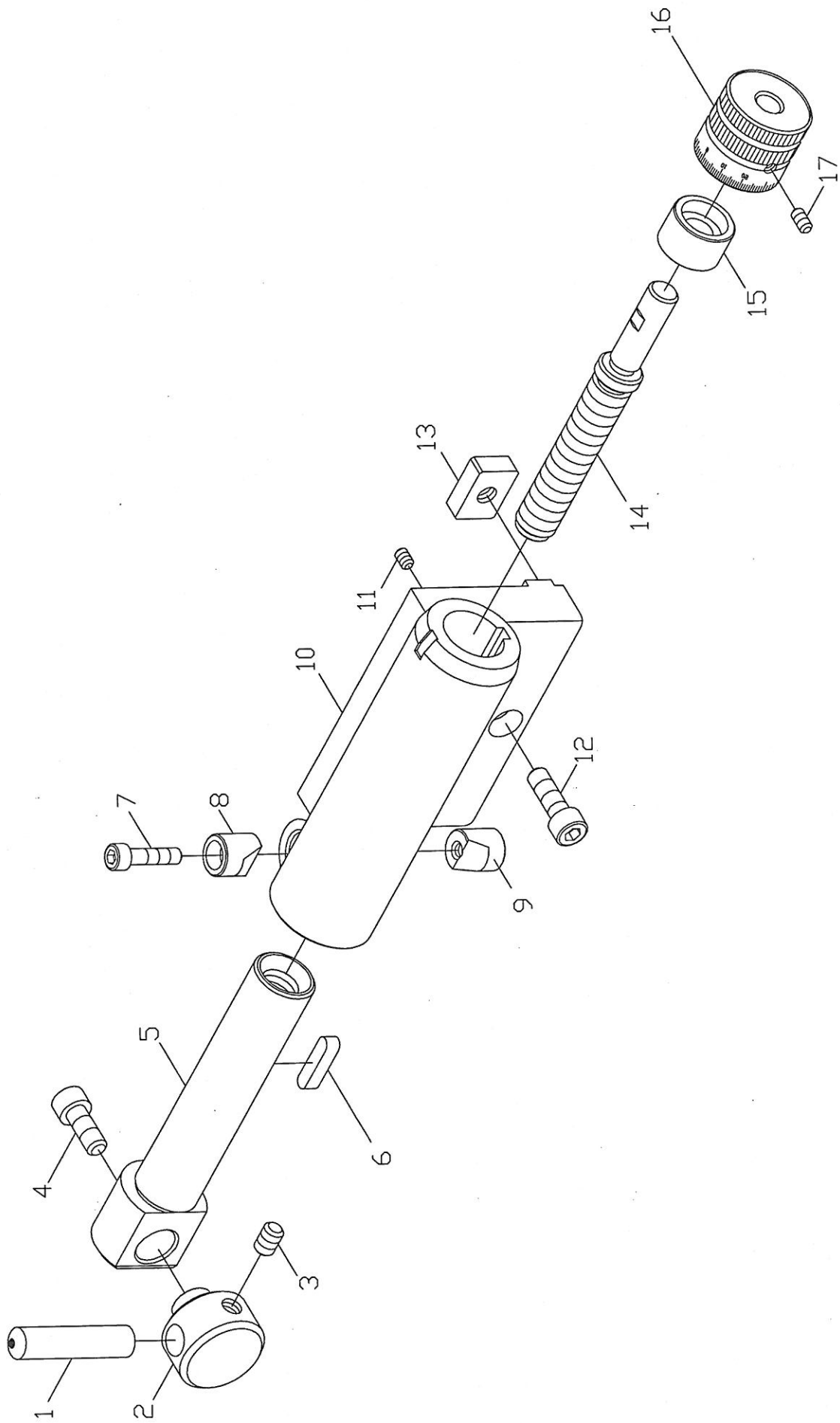

Sharp Industries, Inc.	圖名 (NAME) 尾座固定式微調整型砂輪修整器 Wheel dresser	核准 (APPROVE) 沈世傑	日期 (DATE) 2004.07.12	圖號 (NUMBER) PB030220
------------------------	---	---------------------	-------------------------	-------------------------



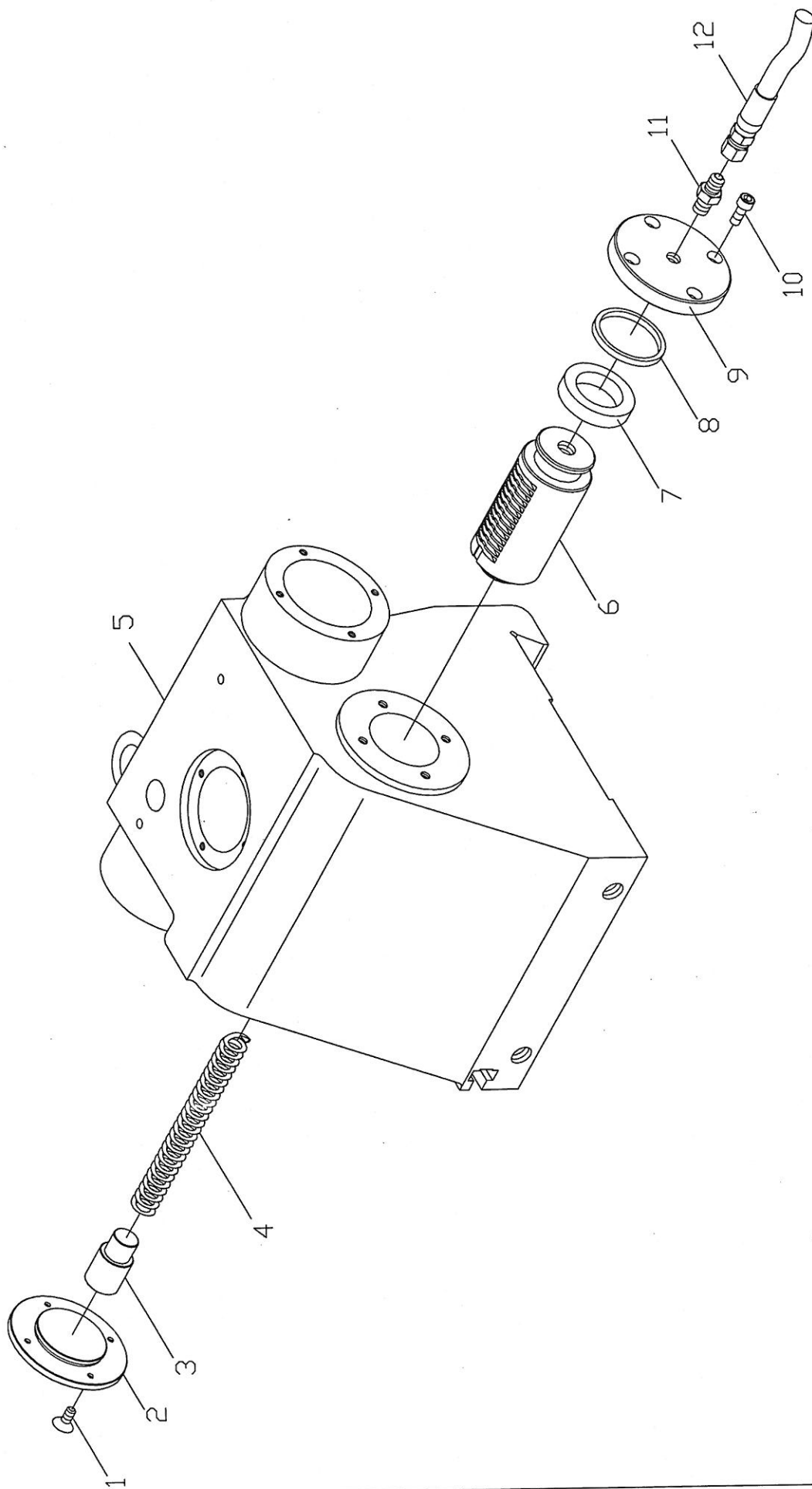

Sharp Industries, Inc.		圖名 (NAME)	核准 (APPROVE)	日期 (DATE)	圖號 (NUMBER)
油壓尾座	Hydraulic tail stock	沈世傑	2003.06.05	PB030320	





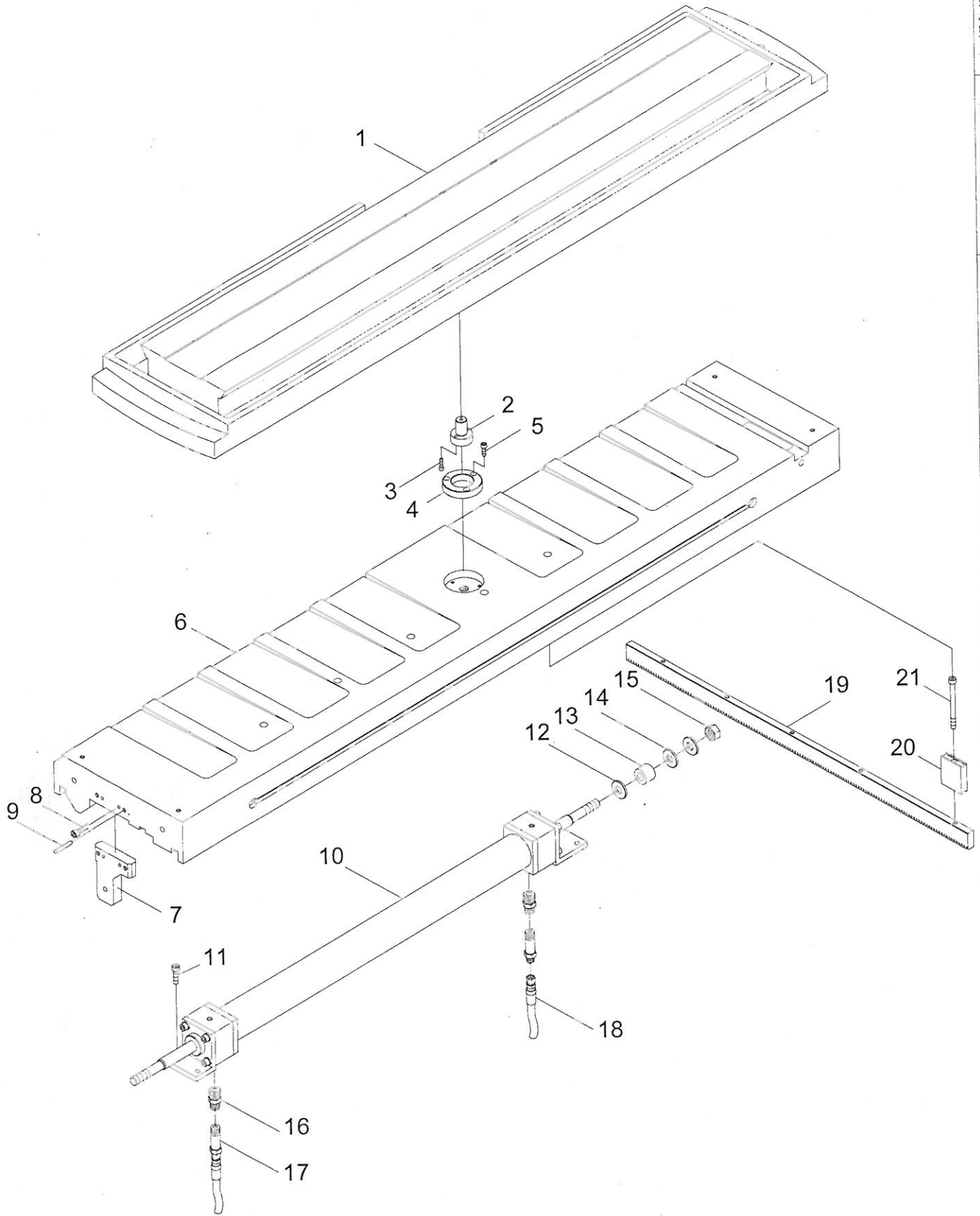

圖號 (NUMBER)  
PB060120

日期 (DATE)  
2004.07.12

核准 (APPROVE)  
沈世傑

圖名 (NAME)  
工作滑板 Table

Sharp Industries, Inc.

圖號(NUMBER):	PB060120
圖名(DRAWING):	工作滑板
	TABLE
日期 DATE):	2004.07.12
頁數(PAGE):	1-2

NO.	件號/Parts No.	件名	Description	Remarks	Qty.
1.	KN061508	工作滑板	Table	(G32P-60 , G38P-60)	1
	KN360207	工作滑板	Table	(G32P-100 , G38P-100)	1
	KN560203	工作滑板	Table	(G32P-150 , G38P-150)	1
	KN760106	工作滑板	Table	(G32P-200 , G38P-200)	1
	KN860106	工作滑板	Table	(G50P-250)	1
2.	KB060600	旋轉軸	Pivot		1
3.		內六角螺絲	Socket screw	M5×16L	2
4.	KB060507	軸襯	Bushing		1
5.		內六角螺絲	Socket screw	M6×1×20L	3
6.	KN060105	下滑板	Table slide	(G32P-60 , G38P-60)	1
	KN360104	下滑板	Table slide	(G32P-100 , G38P-100)	1
	KN560100	下滑板	Table slide	(G32P-150 , G38P-150)	1
	KN760106	下滑板	Table slide	(G32P-200 , G38P-200)	1
	KN860209	下滑板	Table slide	(G50P-250)	1
7.	KB060404	活塞桿固定塊	Cylinder bracket		1
8.		內六角螺絲	Socket screw	M8×1.25×30L	2
9.		平行銷	Straight pin	φ 6×40L	1
10.	KB066606	油壓缸組合	Cylinder	(G32P-60 , G38P-60)	1
	KC066802	油壓缸組合	Cylinder	(G32P-100 , G38P-100)	1
	KD065203	油壓缸組合	Cylinder	(G32P-150 , G38P-150)	1
	KE065203	油壓缸組合	Cylinder	(G32P-200 , G38P-200)	1
	KE068309	油壓缸組合	Cylinder	(G50P-250)	1
11.		內六角螺絲	Socket screw	M8×1.25x30L	4
12.	KB066709	墊圈	Washer		4
13.	K4030308	橡皮緩衝器	Rubber buffer		2
14.		彈簧墊圈	Spring washer	φ 16	2
15.		六角螺帽	Hexagon nut	M16	2
16.		接頭(陽)	Pipe connector	PT1/2"×φ 15	2
17.		油壓軟管	Hydraulic pipe	φ 15×820L	1
18.		油壓軟管	Hydraulic pipe	φ 15×780L	1
19.	KB060301	齒條	Rack	(G32P-60 , G38P-60)	1
	KC060301	齒條	Rack	(G32P-100 , G38P-100)	1
	KE060310	齒條	Rack	(G32P-150 , G38P-150)	1
	KD060302	齒條	Rack	(G32P-150 , G38P-150)	1
	KE060310	齒條	Rack	(G32P-200 , G38P-200)	2
	KE067700	齒條	Rack	(G50P-250)	1



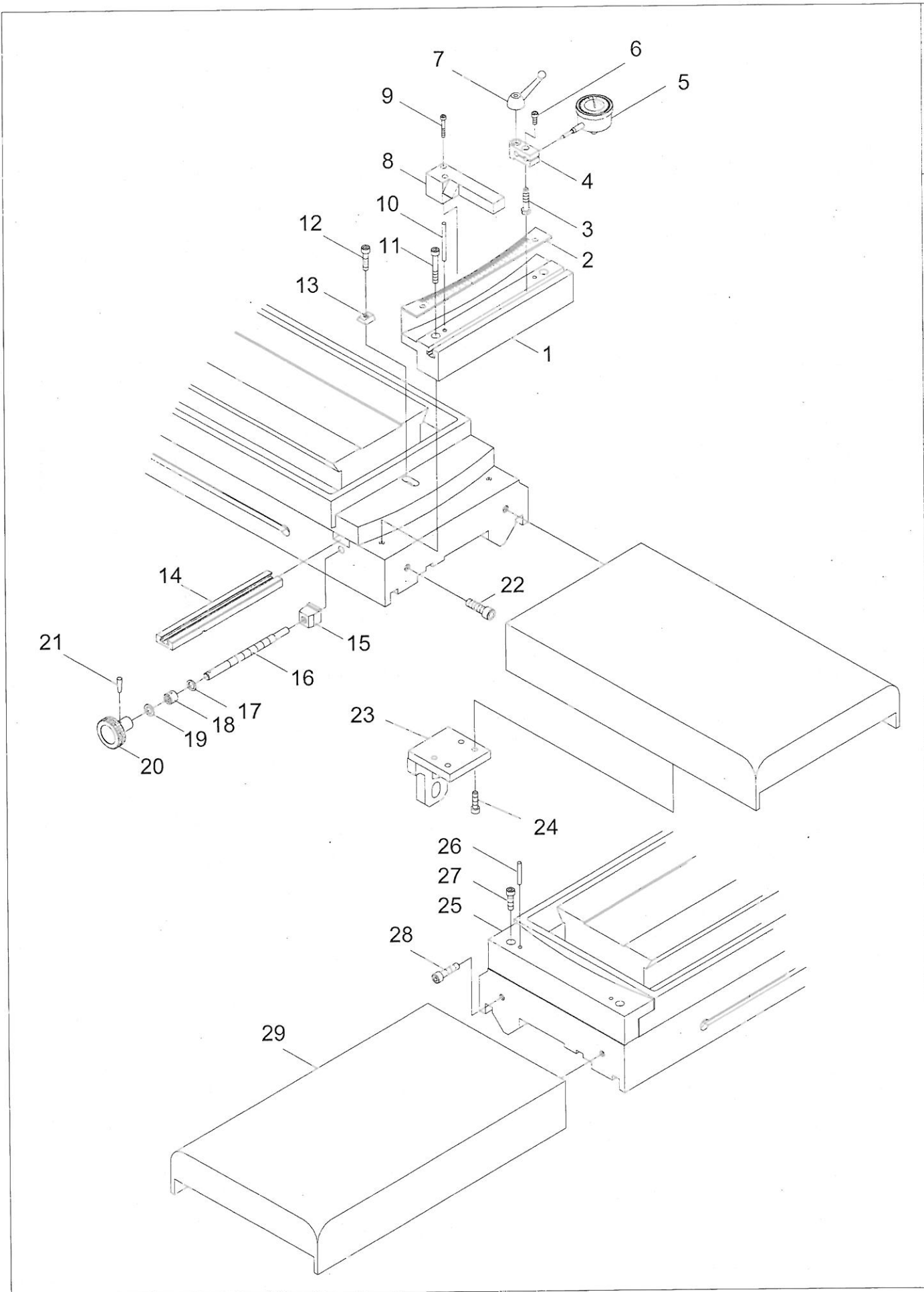

圖號(NUMBER)	圖號(NUMBER)
日期 (DATE)	日期 (DATE)
核准 (APPROVE)	核准 (APPROVE)
圖名 (NAME)	圖名 (NAME)
沈世傑	沈世傑
2004.07.12	2004.07.12
PB060220	PB060220
工作台 II Table II	工作台 II Table II
Sharp Industries, Inc.	

圖號(NUMBER): PB060220

圖名(DRAWING): 工作滑板-II

TABLE - II

日期(DATE): 2004.07.12

頁數(PAGE): 2-1

NO.	件號/Parts No.	件名	Description	Remarks	Qty.
1.	KN060404	右定位片	Locating plate (R)		1
2.	KN060600	刻度銘牌	Dial plate	(G32P-60 , G38P-60)	1
	KN360403	刻度銘牌	Dial plate	(G32P-100 , G38P-100)	1
	KN560409	刻度銘牌	Dial plate	(G32P-150 , G38P-150)	1
	KN760302	刻度銘牌	Dial plate	(G32P-200 , G38P-200)	1
3.	KB062200	固定螺絲(二)	Setting screw(2)		1
4.	KB062303	量錶固定塊	Indicator seat		1
5.		量錶	Dial indicator	0.01mm	1
6.		內六角螺絲	Socket screw	M6×15L	1
7.		活動把手	Lever	M6	1
8.	KN062004	歸零指示板	Zero setting stopper		1
9.		皿頭螺絲	Flat head screw	M5×8L	2
10.		平行銷	Pin	φ 6×45L	1
11.		內六角螺絲	Socket screw	M8×30L	2
12.		內六角螺絲	Socket screw	M8×30L	1
13.	KB061405	固定塊	Setting key		1
14.	KB061302	斜度調整板	Angle adjusting plate		1
15.	KB060806	傳動塊	Shaft nut		1
16.	KB060703	斜度調整軸	Angle adjusting shaft		1
17.	KB061003	銅墊圈	Bronze washer		1
18.	KB060909	固定塊	Fixed plate		1
19.	KB061106	銅墊圈	Bronze washer		1
20.	KB061209	旋鈕	Adjusting knob		1
21.		彈簧銷	Spring pin	φ 4×20L	1
22.		內六角螺絲	Socket screw	M10×40L	2
23.	KN060301	油壓缸固定座	Cylinder bracket	(G32P-60 , G38P-60)	1
	KN060301	油壓缸固定座	Cylinder bracket	(G32P-100 , G38P-100)	2
	KN060301	油壓缸固定座	Cylinder bracket	(G32P-150 , G38P-150)	2
	KN060301	油壓缸固定座	Cylinder bracket	(G32P-200 , G38P-200)	2
24.	M8×30L	內六角螺絲	Socket screw	(G32P-60 , G38P-60)	4
	M8×30L	內六角螺絲	Socket screw	(G32P-100 , G38P-100)	8
	M8×30L	內六角螺絲		(G32P-150 , G38P-150)	8
	M8×30L	內六角螺絲	Socket screw	(G32P-200 , G38P-200)	8



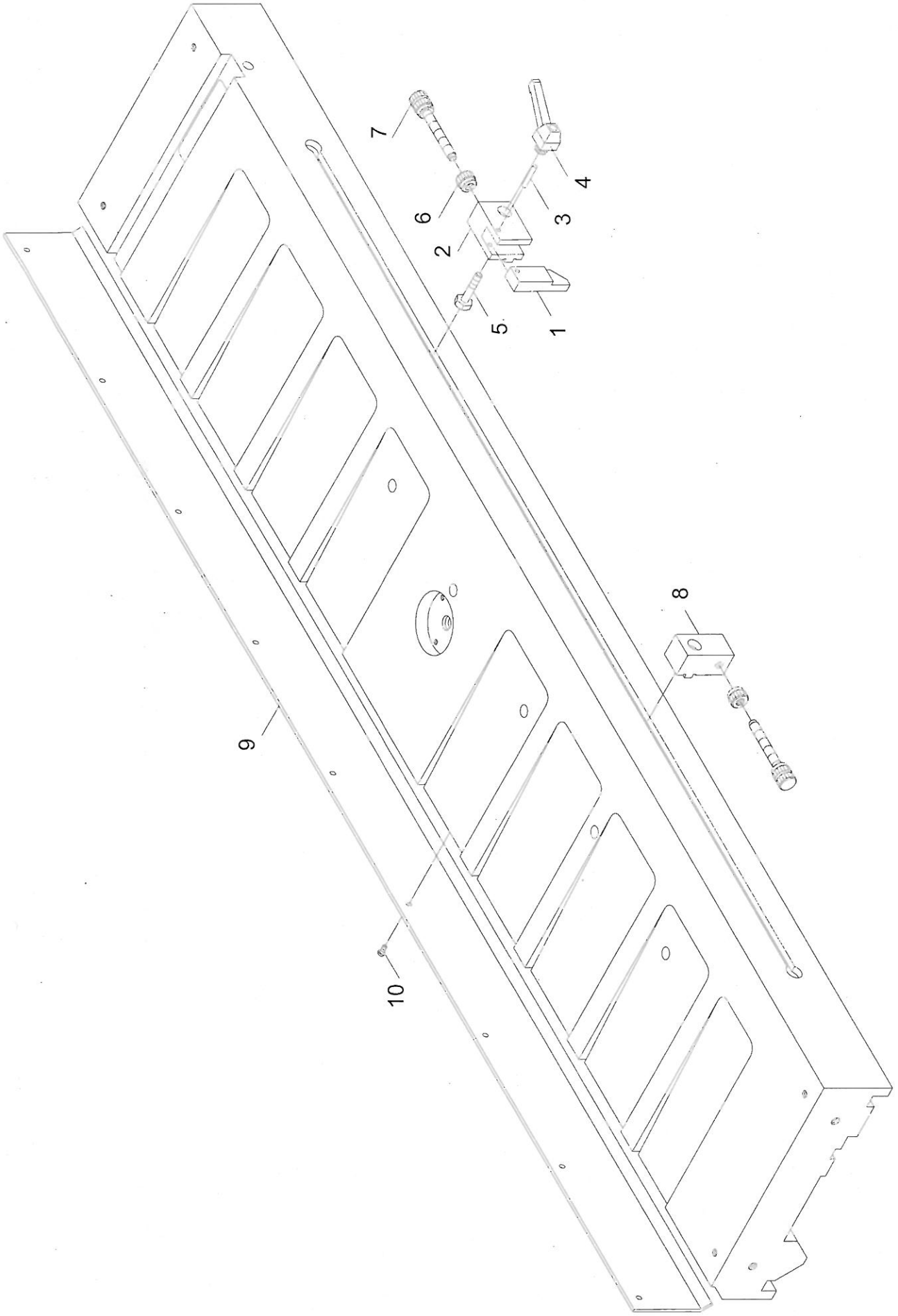

圖號(NUMBER)  
PB060320

日期 (DATE)  
2004.07.12

核准 (APPROVE)  
沈世傑

圖名 (NAME)  
工作台III Table III

Sharp Industries, Inc.





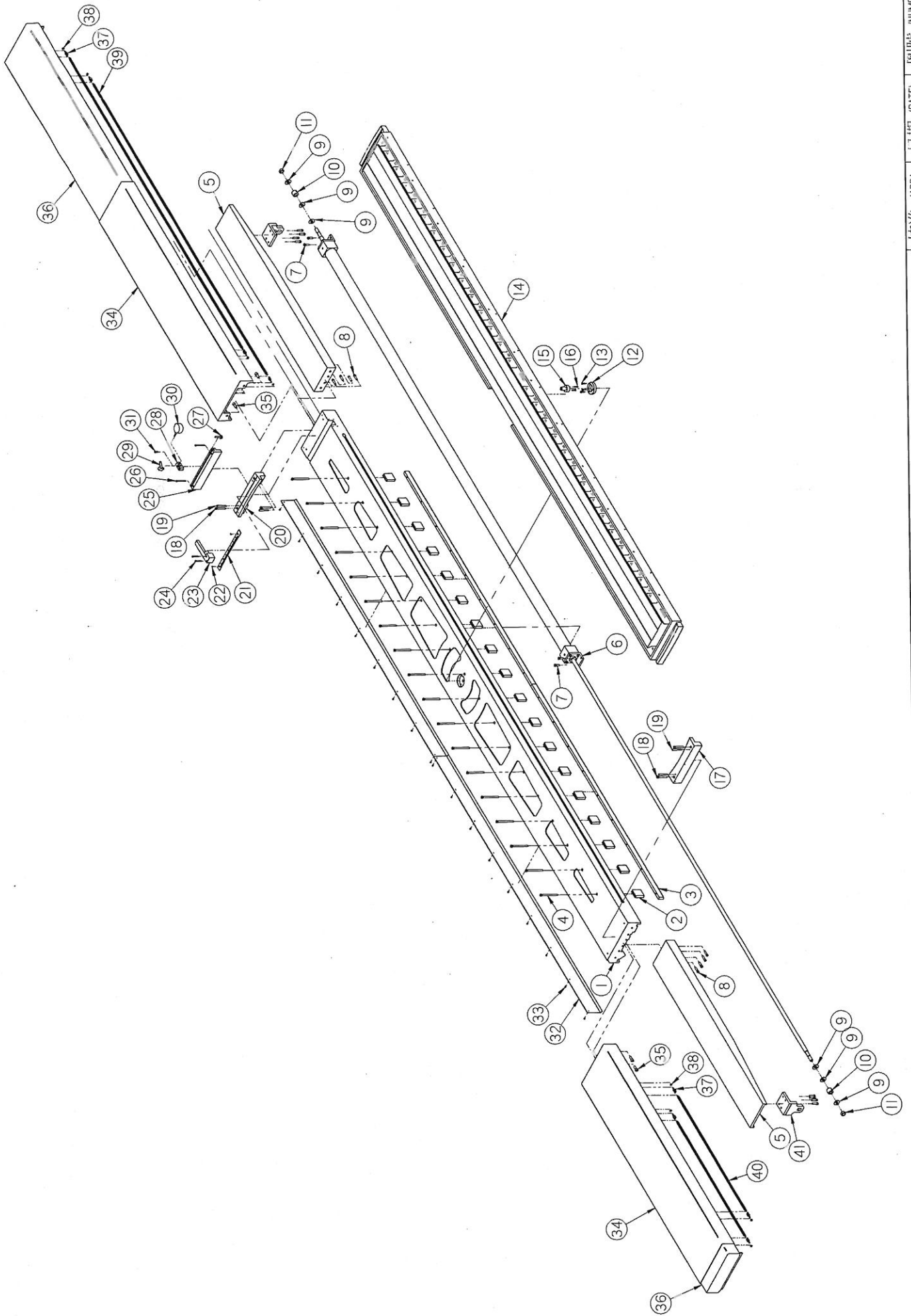

Sharp Industries, Inc.	圖名 (NAME)	工作滑板組 Table slide plate	核准 (APPI) 林崇榮	日期 (DATE) 2012/5/14	圖號 (NUMBER) ANS60100
------------------------	--------------	----------------------------	------------------	------------------------	-------------------------

圖號 (NUMBER)	AN960100
圖名 (DRAWING)	工作滑板組
	Table slide plate
日期 (DATE)	2012/5/14
頁數 (PAGE)	1-2

NO.	Parts No.	件名	Description	Remarks	Qty.
1	KN960100	下滑板	Lower slide plate		1
2	KB060208	墊塊	Block		18
3	KN960300	齒條(一)	Rack		2
4	SD011730	沉頭內六角螺絲	Hex. socket screw	M8x1.25x110L	18
5	KN960400	油壓缸固定座	Cylinder fixed seat		2
6	KE068900	油壓缸	Hydraulic cylinder		1
7	SD011558	沉頭內六角螺絲	Hex. socket screw	M8x1.25x25L	4
8	SD011565	沉頭內六角螺絲	Hex. socket screw	M8x1.25x30L	16
9	KB066709	墊圈	Washer		6
10	K4030308	橡皮緩衝器	Rubber buffer		2
11	SD200082	六角頭螺帽	Hex. head nut	M16x2	2
12	KB060507	軸襯	Bushing		1
13	SD011077	沉頭內六角螺絲	Hex. socket screw	M6x1x20L	3
14	KN960200	工作滑板	Table slide plate		1
15	KB060600	旋轉軸	Rotation axis		1
16	SD010674	沉頭內六角螺絲	Hex. socket screw	M5x0.8x20L	2
17	KN060507	左定位片	Left locating plate		1
18	SD011644	沉頭內六角螺絲	Hex. socket screw	M8x1.25x60L	4
19	SE040105	斜銷(1/50)	Taper pin	φ 6x63L	4
20	KN960800	右定位片	Right setting plate		1
21	KN960900	刻度銘牌	Graduation name plate		1
22	SD050218	平頭六角孔螺絲	Flat socket screw	M4x0.7x8L	2
23	KN063400	歸零指示板	Zero setting indicator plate		1
24	SD010715	沉頭內六角螺絲	Hex. socket screw	M5xP0.8x40L	2
25	KN063200	量表滑道座	Slide way seat		1
26	SD010753	沉頭內六角螺絲	Hex. socket screw		2
27	KB062406	固定螺絲	Fixed screw		1
28	KB062303	量表固定塊	Gage fixed block		1
29	SE630018	把手(活動,內牙,塑膠)	Handle bar	M8(NO.78)	1
30	SZ500500	濃百分錶-Mitutoyo	Dial Indicator	2046FE 10mm/0.01	1
31	SD011053	沉頭內六角螺絲	Hex. socket screw	M6x1x16L	1

圖號 (NUMBER)	AN960100
圖名 (DRAWING)	工作滑板組
	Table slide plate
日期 (DATE)	2012/5/14
頁數 (PAGE)	2-2

NO.	Parts No.	件名	Description	Remarks	Qty.
32	KN961500	洩水板	Drain plate		2
33	SD040039	半圓頭六角孔螺絲	Round Head Socket Screw	M4xP0.7x8L	18
34	KN960500	側翼(一)	Side wing(一)		2
35	SD012047	沉頭內六角螺絲	Hex. socket screw	M10x1.5x25L	4
36	KN960600	側翼(二)	Side wing(二)		2
37	KE060703	彈簧固定座	Spring fixed seat		8
38	SD200037	六角頭螺帽	Hex. head nut	M6x1	8
39	KN960700	拉伸彈簧	Tension spring		2
40	KN960700	拉伸彈簧	Tension spring		2
41	KN060301	油壓缸固定座			2

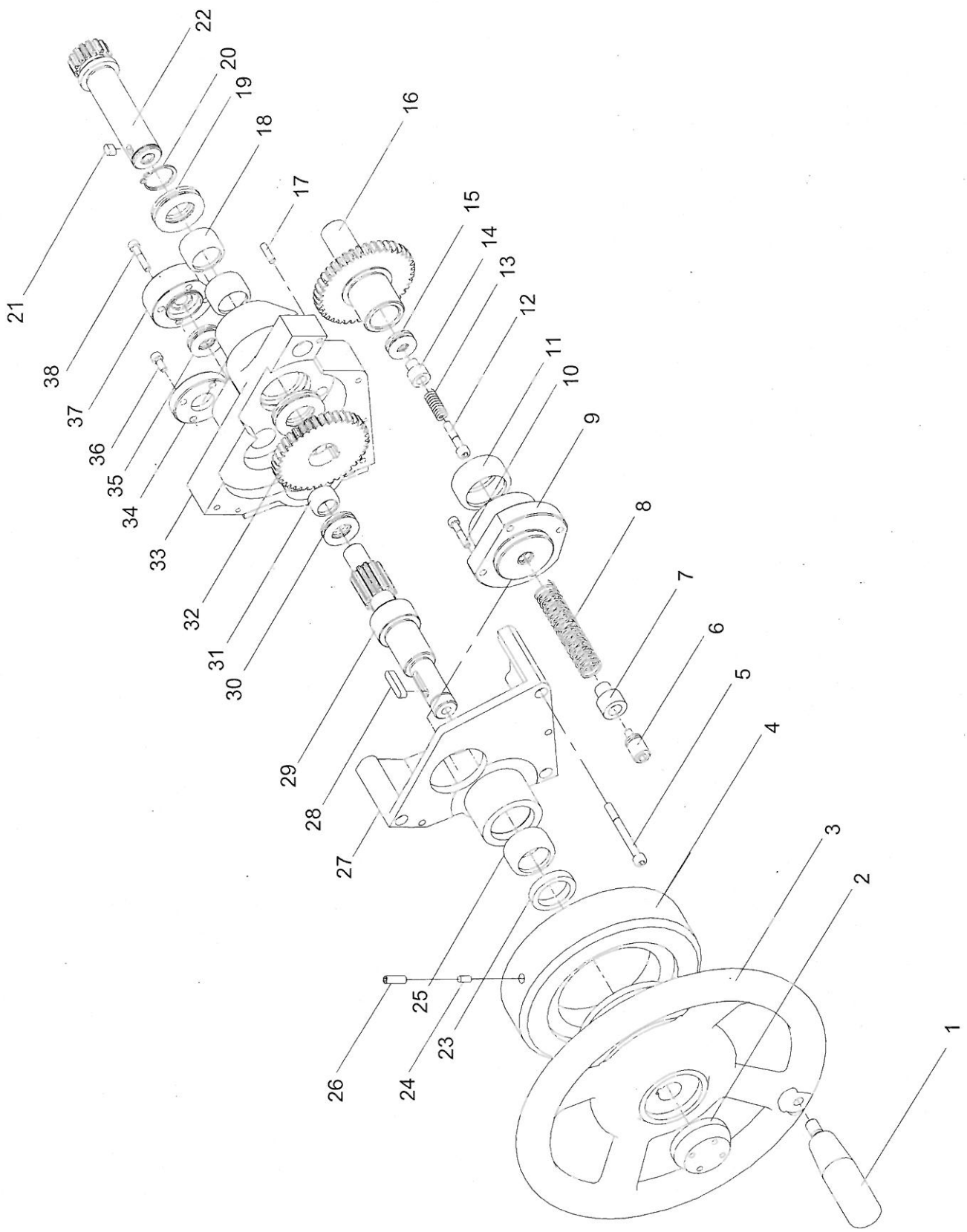

圖號(NUMBER):	PB060420
圖名(DRAWING):	齒輪座 RACK SEAT
日期 DATE):	2003.06.09
頁數(PAGE):	2-1

NO.	件號/Parts No.	件名	Description	Remarks	Qty.
1.		把手	Handle Bar	M10x1.5	1
2.	KB065100	固定螺帽	Fixed Nut		1
3.	KB066118	手輪	Hand Wheel		1
4.	KN061216	刻度環 (in)	Graduation Ring (in)		1
5.		內六角螺絲	Hex. Socket Screw	M6x1x75L	3
6.	KB064903	調整螺絲	Adjust Screw		1
7.	KB064305	間隔環	Spacer		1
8.	KB063108	彈簧	Spring		1
9.	KD062705	軸承座	Bearing Seat		1
10.		內六角螺絲	Hex. Socket Screw	M6x1x20L	4
11.		滾柱軸承	Needle Roller Bearing	TA3520Z	1
12.		內六角螺絲	Hex. Socket Screw	M6x1x30L	1
13.	KB064800	彈簧	Spring		1
14.	KD062509	軸承固定塊	Bearing Block		1
15.		滾珠軸承	Thrust Ball Bearing	51100	1
16.	KD062303	齒輪軸	Gear Shaft		1
17.		梢	Taper Pin	D5x40L	2
18.		滾柱軸承	Needle Roller Bearing	TA2520Z	2
19.		滾珠軸承	Thrust Ball Bearing	51105	1
20.		外固定環	Outer Retaining Ring	S25	1
21.		鍵	Key	6x6x10L	1
22.	KD062406	傳動齒輪(1)	Transmission Gear(1)		1
23.		油封	Oil Seal	TC28.38.7	1
24.		銅棒	Copper Bar	D5	1
25.		滾柱軸承	Needle Roller Bearing	TA2820Z	1
26.		固定螺絲	Fixed Screw	M6x1x20L	1
27.	KD064714	齒輪座蓋	Gear Seat Cover		1
28.		內六角螺絲	Key	5x5x28L	1
29.	KD062004	驅動齒輪	Driving Gear		1
30.		滾珠軸承	Thrust Ball Bearing	51103	1
31.		滾柱軸承	Needle Roller Bearing	TA1715Z	1
32.	KD062602	傳動齒輪(2)	Transmission Gear(2)		1
33.	KD063816	齒輪座	Gear Seat		1



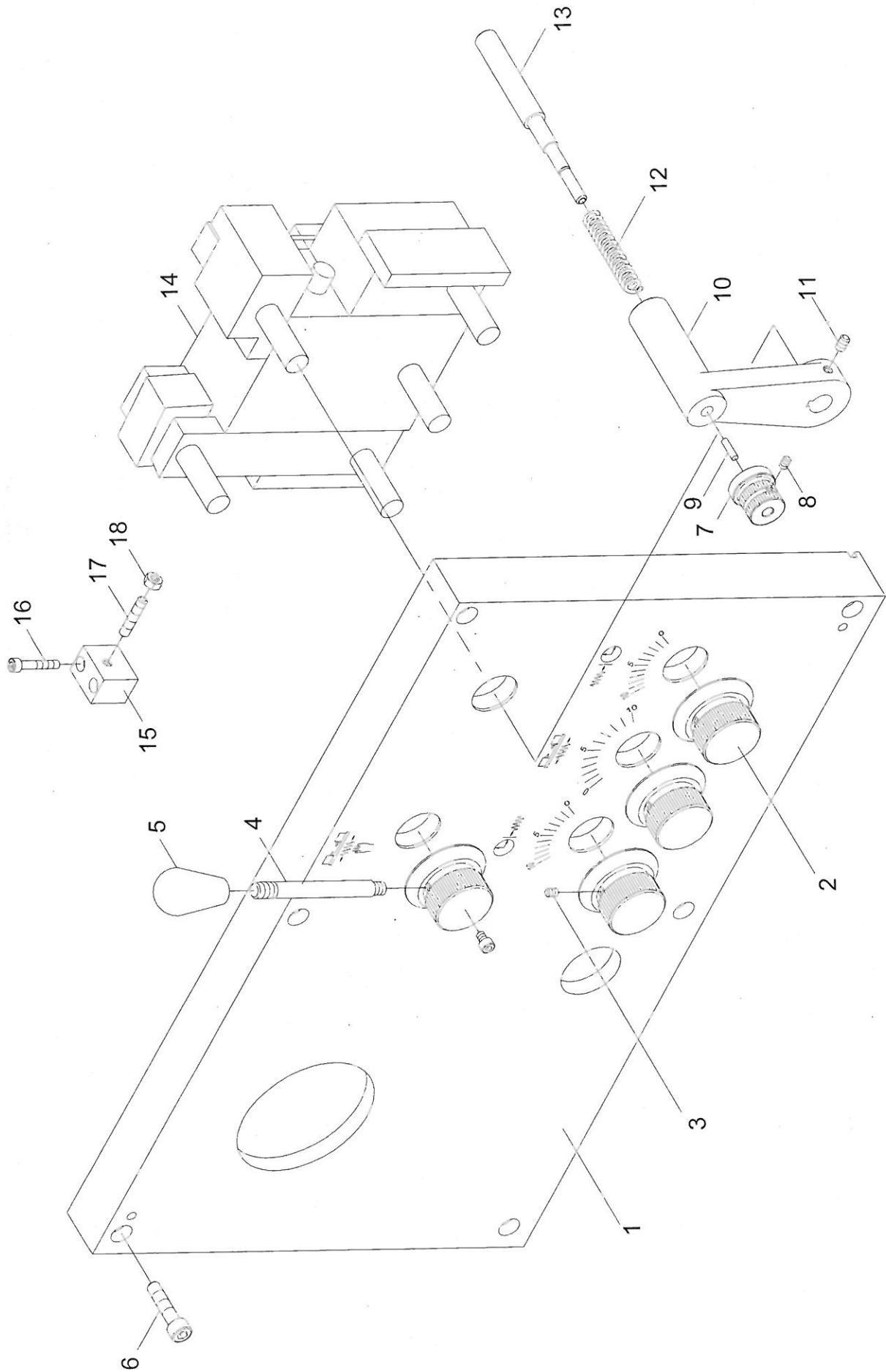





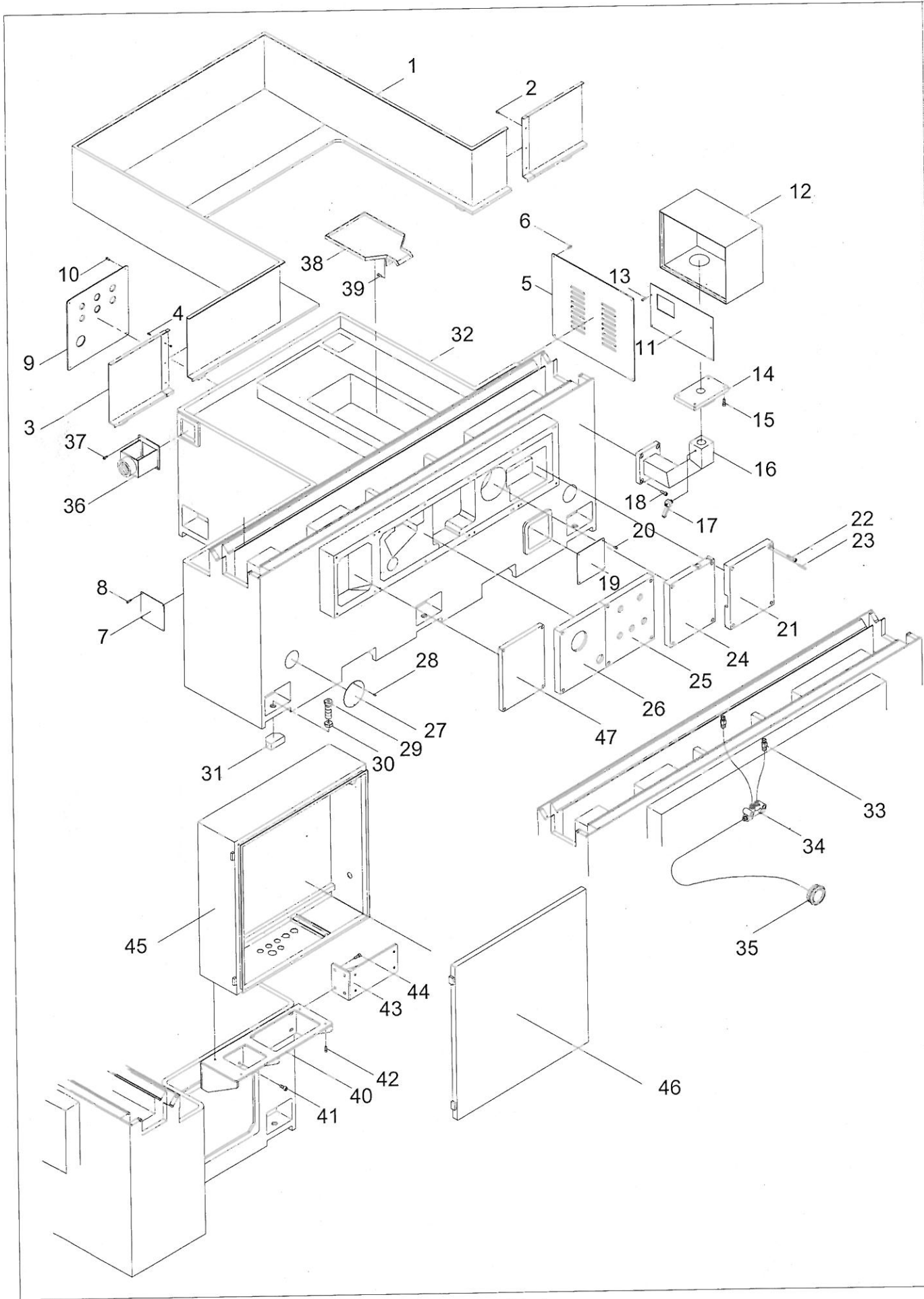

圖號(NUMBER)	圖號(NUMBER)	圖號(NUMBER)
日期 (DATE)	日期 (DATE)	日期 (DATE)
批准 (APPROVE)	批准 (APPROVE)	批准 (APPROVE)
圖名 (NAME)	圖名 (NAME)	圖名 (NAME)
沈世傑	沈世傑	沈世傑
Base	Base	Base
本台	本台	本台
Sharp Industries, Inc.	Sharp Industries, Inc.	Sharp Industries, Inc.

圖號(NUMBER):	PB070120
圖名(DRAWING):	本台
	BASE
日期 DATE):	2007.09.10
頁數(PAGE):	2-1

NO.	件號/Parts No.	件名	Description	Remarks	Qty.
1.	KN070205	後擋水板	Rear splash guard	(G32P-60 , G38P-60)	1
	KN370606	後擋水板	Rear splash guard	(CE)	1
	BD070308	後擋水板	Rear splash guard	(CE)	1
2.	KN370307	後擋水板(右)	Rear splash guard(R)	(G32P-100 , G38P-100)	1
	KN570303	後擋水板(右)	Rear splash guard(R)	(G32P-150 , G38P-150)	1
	KN770309	後擋水板(右)	Rear splash guard(R)	(G32P-200 , G38P-200)	1
	BD070205	後擋水板(右)	Rear splash guard(R)	(CE)	1
3.	KN370204	後擋水板(左)	Rear splash guard(L)	(G32P-100 , G38P-100)	1
	KN570200	後擋水板(左)	Rear splash guard(L)	(G32P-150 , G38P-150)	1
	KN770206	後擋水板(左)	Rear splash guard(L)	(G32P-200 , G38P-200)	1
	BD070102	後擋水板(左)	Rear splash guard(L)	(CE)	1
4.		內六角圓頭螺絲	Sunk screw	M5×15L	6
5.	KN070607	本台側蓋板	Side cover		1
6.		內六角圓頭螺絲	Sunk screw	M6×1×15L	4
7.	KN071309	本台前蓋板	Base side cover		1
8.		內六角圓頭螺絲	Sunk screw	M6×1×15L	4
9.	KN070906	本台後蓋板	Base rear cover		1
10.		內六角圓頭螺絲	Sunk screw	M6×1×15L	4
11.	KB163819	操作面板 (CII)	Control panel (CII)		1
	KB163905	操作面板 (H)	Control panel (H)		1
12.	KN073300	操作箱 (CII)	Control panel box (CII)		1
	KB076201	操作箱 (H)	Control panel box (H)		1
13.		內六角圓頭螺絲	Sunk screw	M6×1×15L	8
14.	KB070803	操作箱支持座	Supporting seat		1
15.		內六角螺絲	Socket screw	M8×1.25×25L	4
16.	KB070607	操作箱支臂	Supporting arm		1
17.		把手	Handle	M8	1
18.		內六角螺絲	Socket screw	M8×1.25×25L	4
19.	KN070700	本台前蓋板	Base front cover		1
20.		內六角圓頭螺絲	Sunk screw	M6×1×15L	4
21.	KC070205	前蓋板 (一)	Front cover (1)		1
22.		內六角螺絲	Socket screw	M8×1.25×50L	18
23.		斜銷	Tapered pin	φ 6×50L	6
24.	KN074704	前蓋板 (二)	Front cover (2)		1



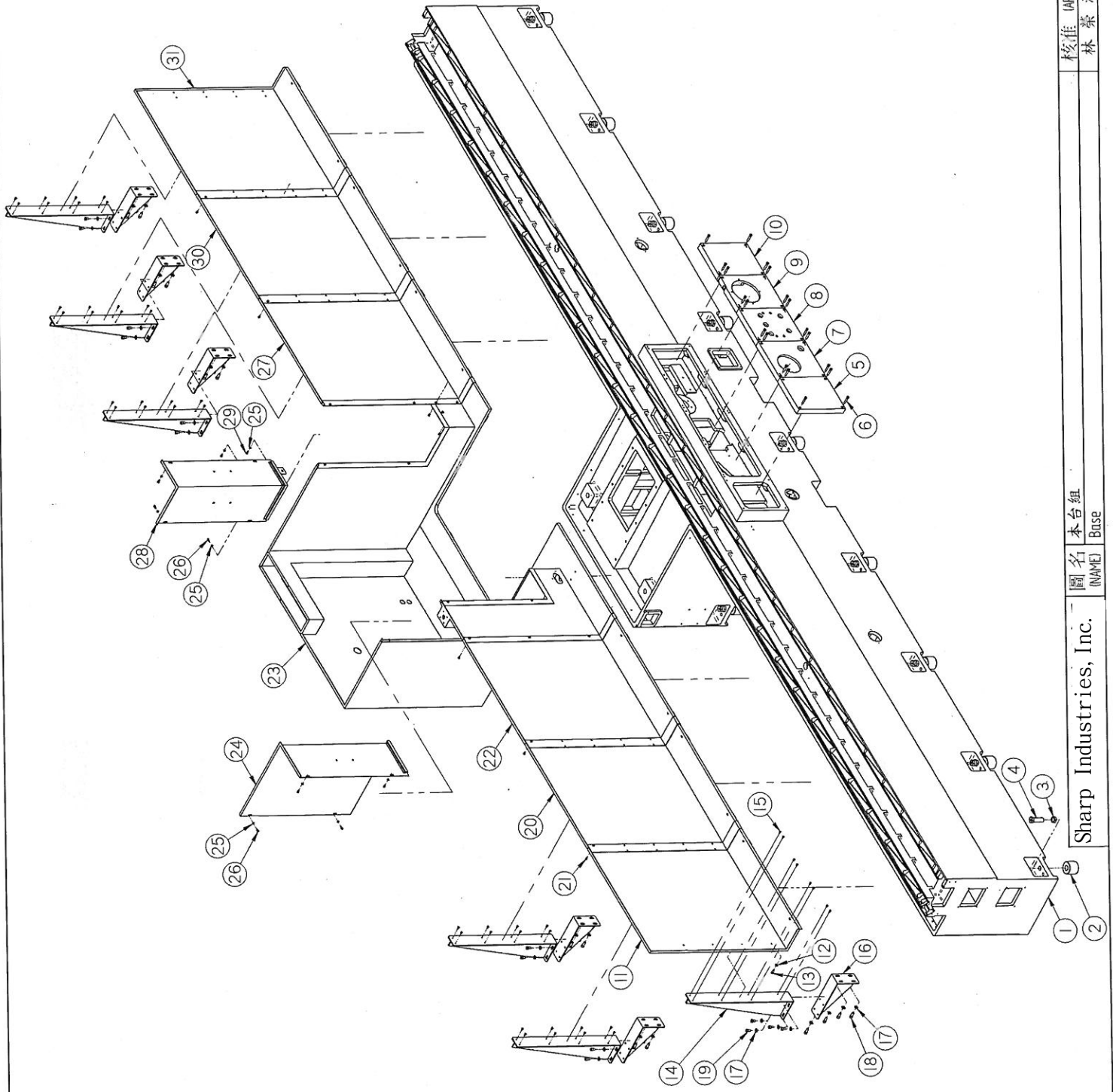

核准 (APP) 日期 (DATE) 圖號 (NUMBER)  
 林榮添 2012.5/10 AN970100

圖名 (NAME) 本台組 (BASE)  
 Sharp Industries, Inc.

圖號 (NUMBER)	AN970100
圖名 (DRAWING)	本台組
	Base
日期 (DATE)	2012/5/10
頁數 (PAGE)	1-2

NO.	Parts No.	件名	Description	Remarks	Qty.
1	KN970100	本台	Base		1
2	K4058900	基礎墊塊	Base block		20
3	KN070401	調整螺帽	Adjusting nut		20
4	KN070504	調整螺絲	Adjusting screw		20
5	KC079709	前蓋板(五)	Front cover plate(五)		1
6	SD011606	沉頭內六角螺絲	Hex. socket screw	M8x1.25x40L	20
7	KC070906	前蓋板(四)	Front cover plate(四)		1
8	KC070803	前蓋板(三)	Front cover plate(三)		1
9	KN071000	前蓋板(二)	Front cover plate(二)		1
10	KC070205	前蓋板(一)	Front cover plate(一)		1
11	KN970900	左擋水板(三)	Left splash guard plate(三)		1
12	SD800042	平墊圈	Flat washer	M8	17
13	SD011534	沉頭內六角螺絲	Hex. socket screw	M8x1.25x16L	17
14	KN970300	固定架(二)	Fixed bracket(二)		6
15	SD040637	半圓頭六角孔螺絲	Round head socket screw	M6x1x10L	48
16	KN970200	固定架(一)	Fixed bracket(一)		6
17	SD800059	平墊圈	Flat washer	M10	48
18	SD012047	沉頭內六角螺絲	Hex. socket screw	M10x1.5x25L	24
19	SD012023	沉頭內六角螺絲	Hex. socket screw	M10x1.5x16L	24
20	KN970800	左擋水板(二)	Left splash guard plate(二)		1
21	SD040637	半圓頭六角孔螺絲	Round head socket screw	M6x1x10L	9
22	KN970700	左擋水板(一)	Left splash guard plate(一)		1
23	KN870200	後擋水板	Rear splash guard		1
24	KN870300	左側門	Left side door		1
25	SD800035	平墊圈	Flat washer	M6	9
26	SD011046	沉頭內六角螺絲	Hex. socket screw	M6x1x12L	8
27	KN970400	右擋水板(一)	Right splash guard plate(一)		1
28	KN870700	右側門	Right side door		1
29	SD011050	沉頭內六角螺絲	Hex. socket screw	M6x1x14L	1
30	KN970500	右擋水板(二)	Right splash guard plate(二)		1

圖號 (NUMBER)	AN970100
圖名 (DRAWING)	本台組
	Base
日期 (DATE)	2012/5/10
頁數 (PAGE)	2-2

NO.	Parts No.	件名	Description	Remarks	Qty.
31	KN970600	右擋水板(三)	Right splash guard plate(三)		1

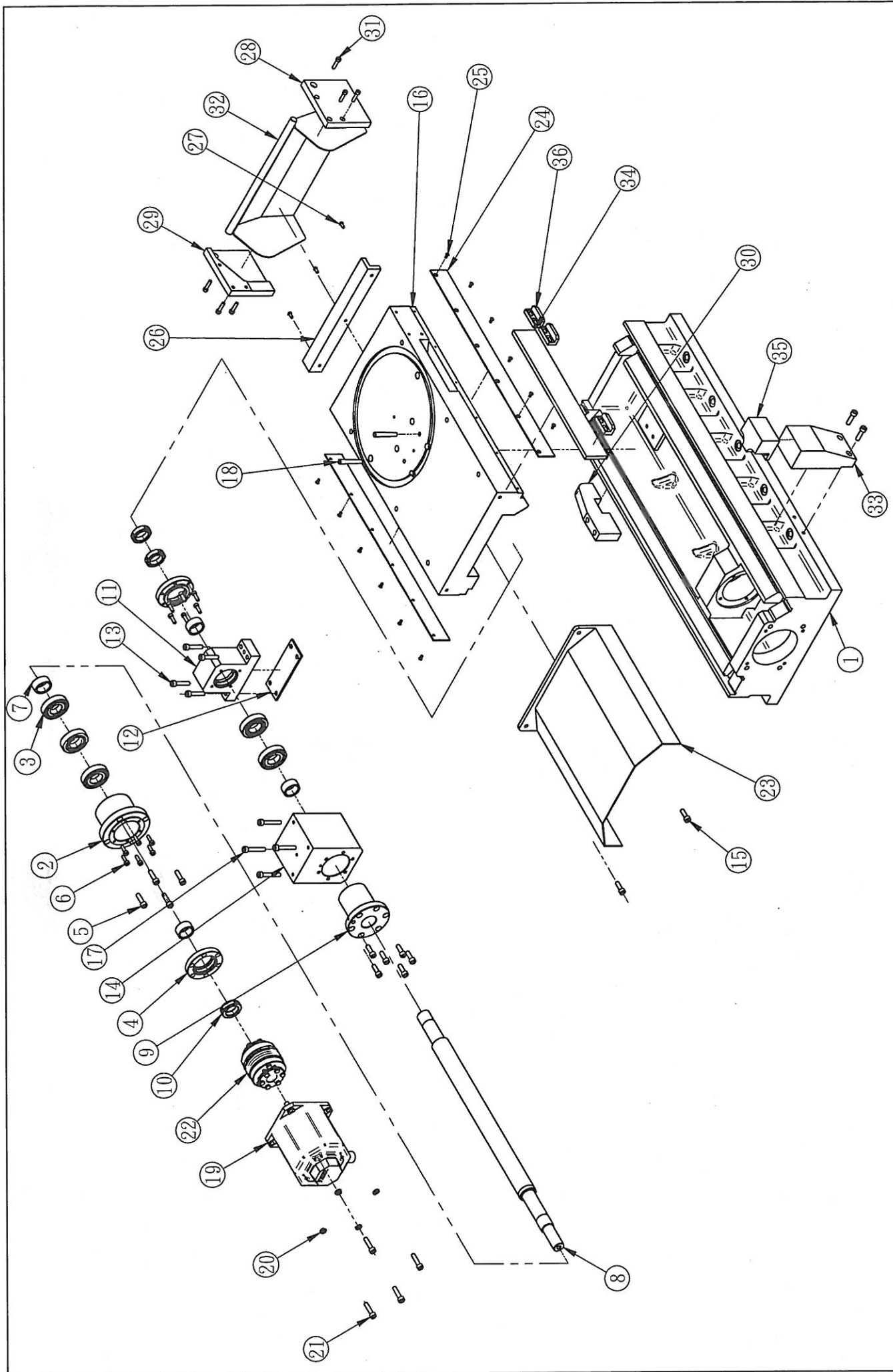

Sharp Industries, Inc.	圖名 (NAME)	圖名 (NAME)	核准 (APP.)	日期 (DATE)	圖號 (NUMBER)
	KF-NC鞍座(直進式) Saddle	KF-NC鞍座(直進式) Saddle	沈世傑	2006.11.07	KF-NC鞍座

圖號(NUMBER):	KF-CNC鞍座(直進式)
圖名(DRAWING):	KF-CNC鞍座(直進式)
	Saddle
日期 DATE):	2006.12.16
頁數(PAGE):	1-2

NO.	件號/Parts No	件名	Description	Remarks	Qty.
1	KF052100	鞍座	Saddle		1
2	KF052409	軸承座	Bearing seat		1
3	SA040015	斜角滾珠軸承	Angular Ball Bearing	[NSK]30TAC62B	5
4	KF052612	軸承座蓋	Bearing seat cover	D90*22	2
5	SD011565	六角孔螺絲	Hex. Socket screw	M8x1.25x30L	6
6	SD011077	六角孔螺絲	Hex. Socket screw	M6x1x20L	12
7	KF052502	間隔套	Spacer		4
8	KF050500	X 軸滾珠導螺桿	X-AXIS Ball Screw		1
9	KF050500	X軸滾珠螺桿座	X-AXIS Ball Screw Seat		1
10	SD260235	精密鎖緊螺帽	Fine lock nut	YSRM30*1.5P	4
11	KF051109	軸承座	Bearing seat		1
12	KF052801	調整片	Adjusting plate		1
13	SD011606	六角孔螺絲	Hex. Socket screw	M8x1.25x40L	4
14	KF054102	土地公	Lead screw bracket	140*110*110	1
15	SD011541	六角孔螺絲	Hex. Socket screw	M8x1.25x20L	8
16	KF052203	鞍座滑板	Saddle plate		1
17	SD011620	六角孔螺絲	Hex. Socket screw	M8x1.25x50L	4
18	SE070061	斜銷附內牙(1/50)	Taper Pin	φ 8*60L	2
19		伺服馬達	Servo Motor	1KW	1
20	SD810049	彈簧墊圈	Spring washer	M8	4
21	SD011565	六角孔螺絲	Hex. Socket screw	M8x1.25x30L	4
22		聯軸器	Coupling	BK3/80	1
23	KF053613	後防塵罩	Rear dust shield		1
24	KF053101	固定壓板	Fixed plate		2
25	SD050225	平頭六角孔螺絲	Flat socket screw	M4x0.7x10L	12
26	KF053204	防塵擋水壓板	Fixed plate fot dust shield	L323*W35*H35	1
27	SD040345	圓頭六角孔螺絲	Round Head Socket Screw	M5x0.8x12L	3
28	KF050816	防塵罩左側壓板	Bracket (L)	L138*W120*H18	1
29	KF050713	防塵罩右側壓板	Bracket (R)	L138*W120*H18	1
30	KC051109	前防塵罩滑塊	Front dust guard slide block	22*160*61	1
31	SD011077	六角孔螺絲	Hex. Socket screw	M6x1x20L	6
32	KF052014	前防塵罩	Front dust shield		1
33	KF053314	極限開關支架	Limit Switch Bracket		1





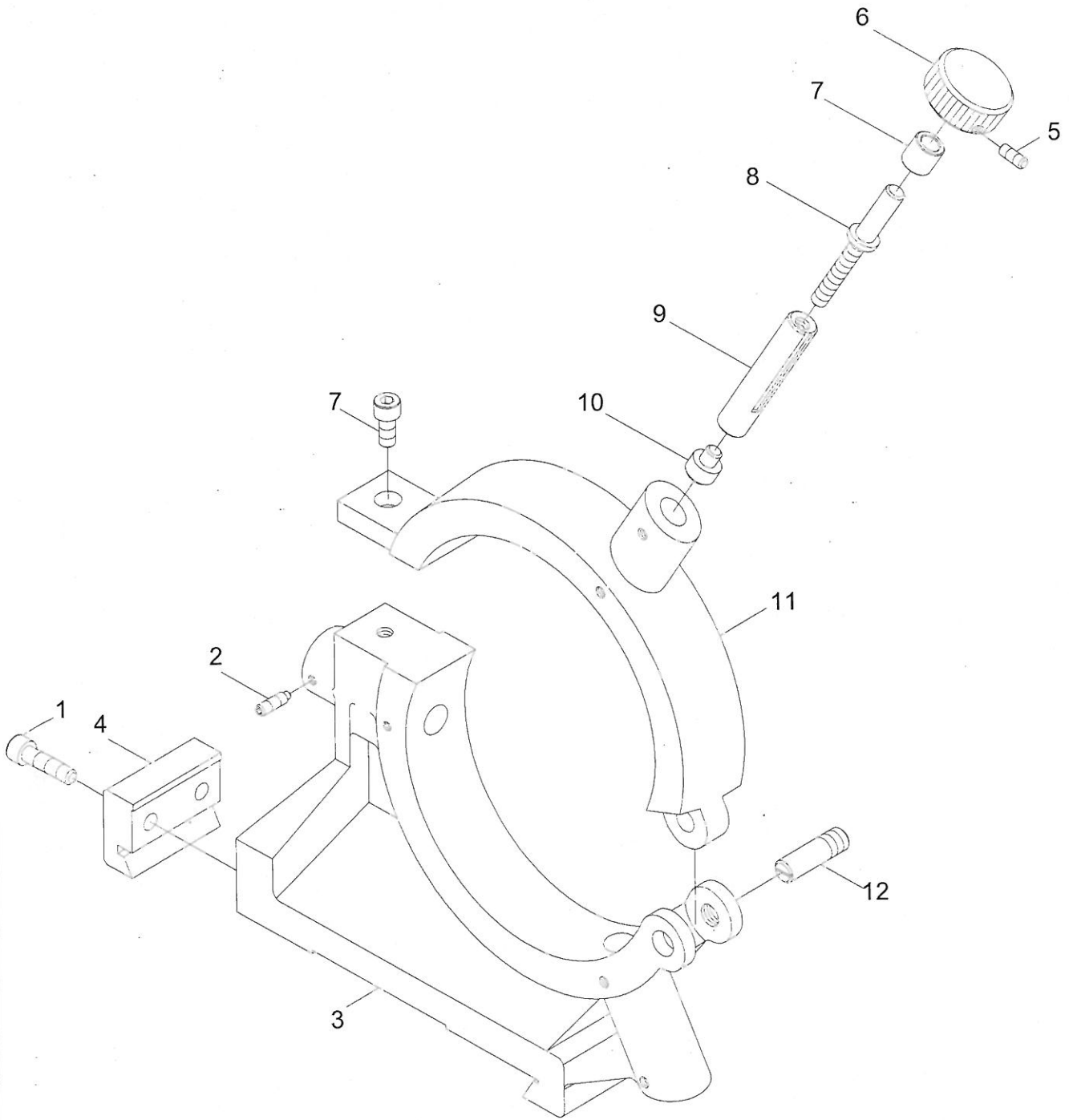

圖號(NUMBER)  
PB140120

日期 (DATE)  
2003.06.09

核准 (APPROVE)  
沈世傑

圖名 (NAME)  
三點式支持架(選購) 3-Point ateady rest(OPT)

Sharp Industries, Inc.



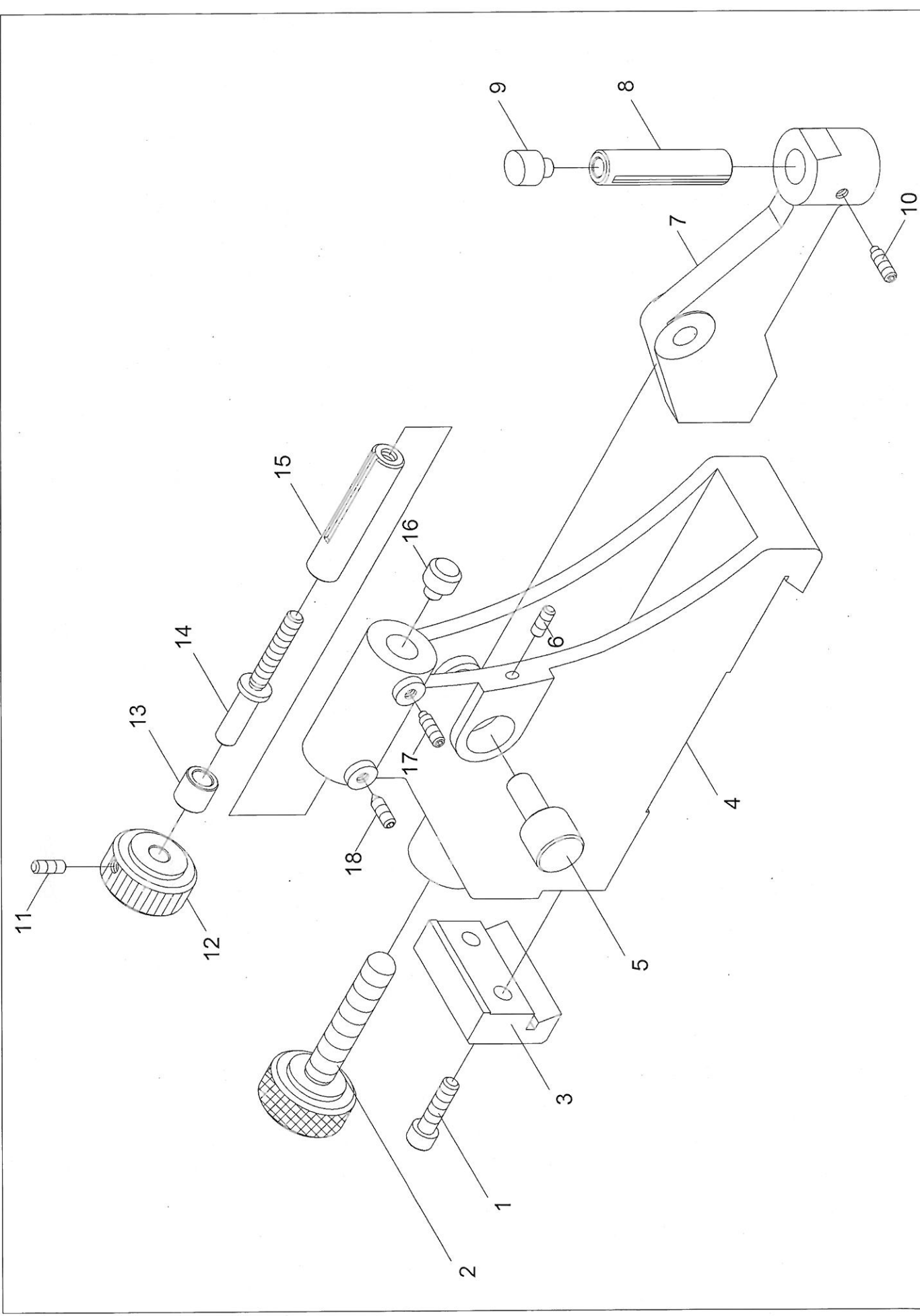

Sharp Industries, Inc.	圖名 (NAME) 二點支持架(選購)2-Point steady rest(OPT)	核准 (APPROVE) 沈世傑	日期 (DATE) 2003.06.09	圖號 (NUMBER) PB140220
------------------------	--	---------------------	-------------------------	-------------------------



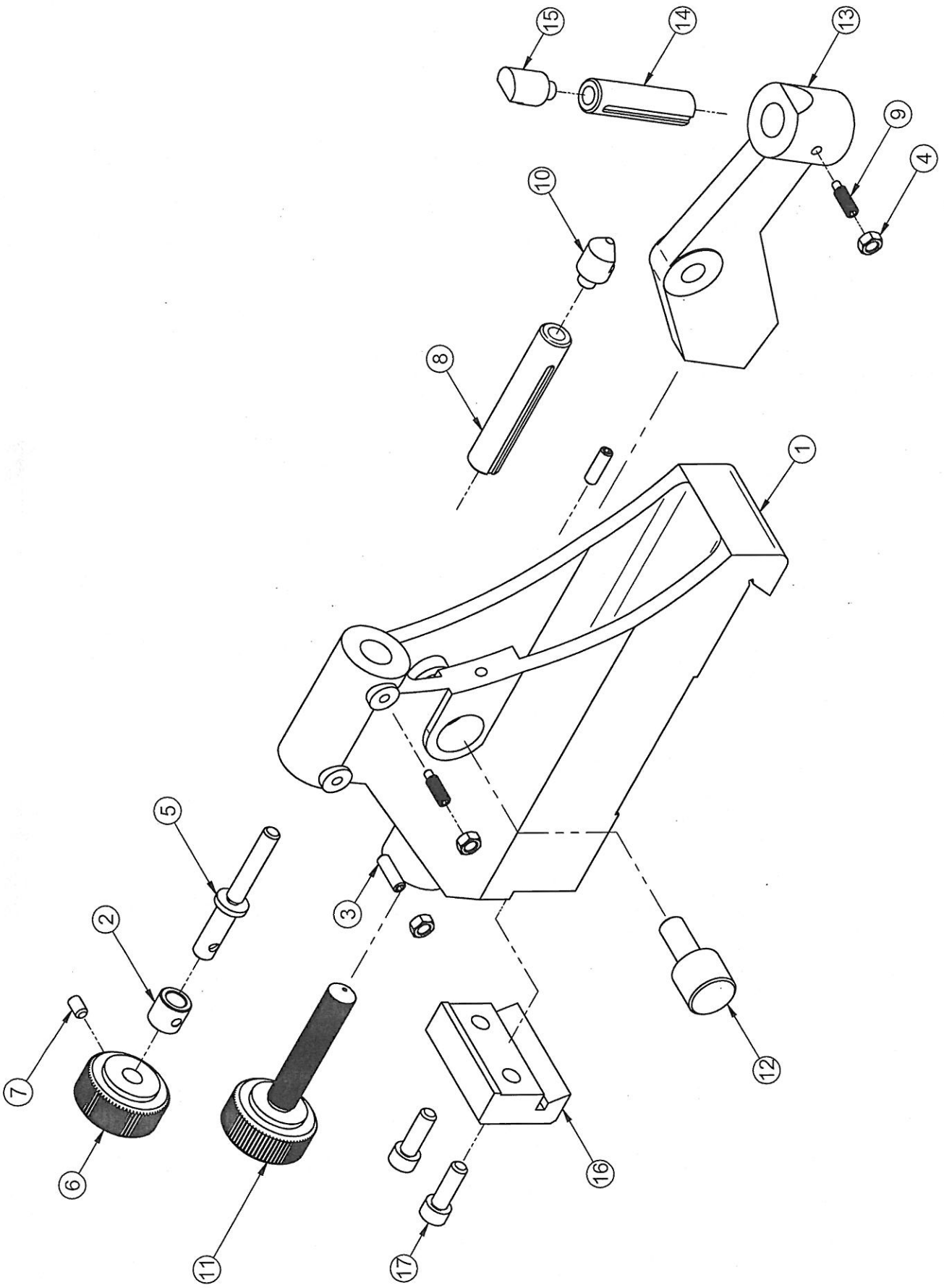

圖名 (NAME)	圖號 (NUMBER)
兩點支持架(選購) (Ø4~Ø35) 2-Point steady rest(OPT) (Ø4~Ø35)	圖號 (NUMBER) ANI40104
核准 (APP.)	日期 (DATE)
沈世傑	2005/2/5

Sharp Industries, Inc.



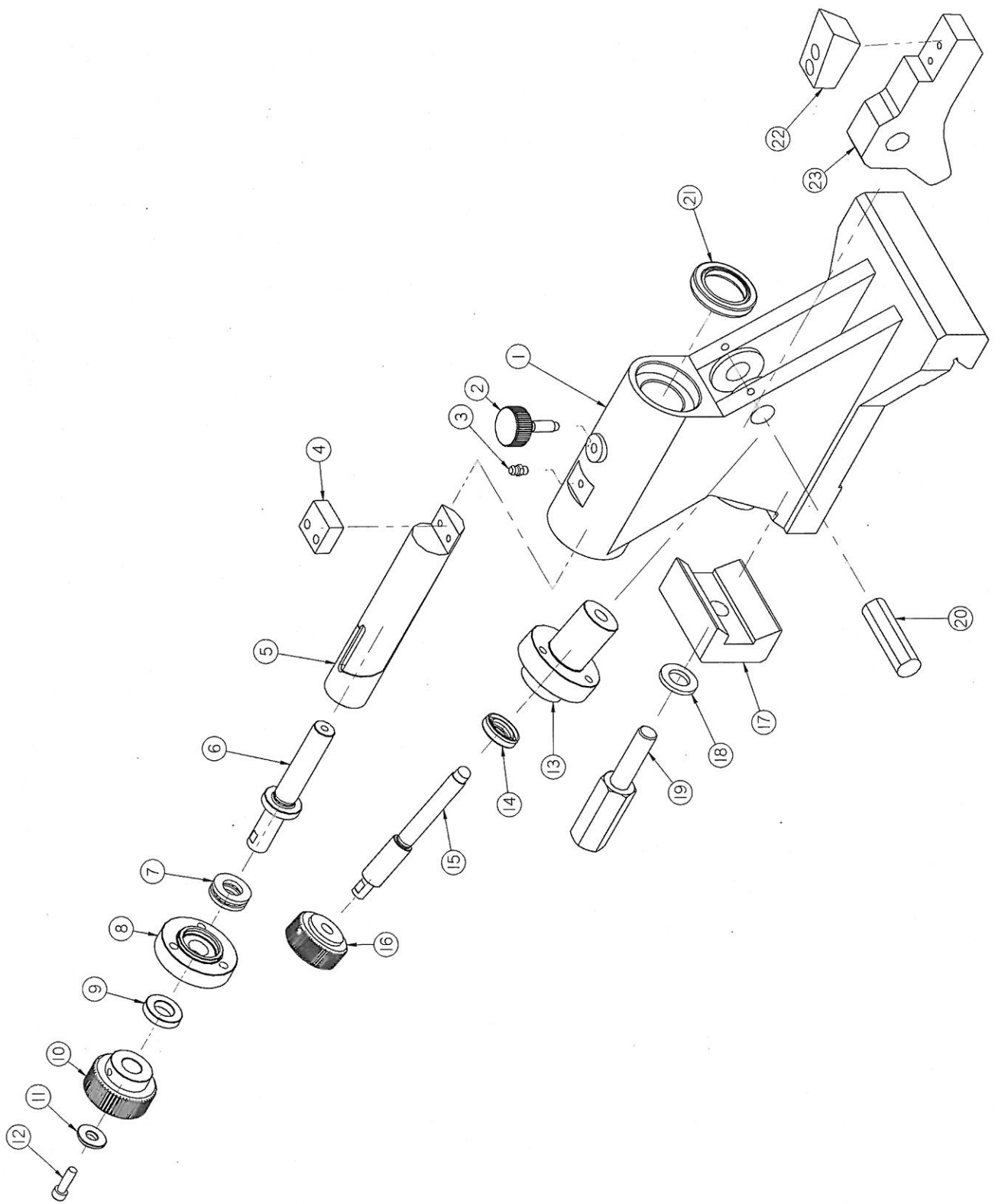

Sharp Industries, Inc.	圖名 (NAME)	兩點支持架(20~80mm) 2-Point steady rest	核准 (APP.)	日期 (DATE)	圖號 (NUMBER)
			林業添	2014/7/4	AGC2101/014



圖號 (NUMBER)	AGC21014014	2階
圖名 (DRAWING)	兩點支持架(20~80mm) 2-Point steady rest	
日期 (DATE)	2014/7/4	
頁數 (PAGE)	2-1	

NO.	Parts No.	件名	Description	Remarks	Qty.
1	KN140007	兩點支持架(螺桿專用)(G32)	2-Point steady rest		1
2	KN140017	調整螺栓	Adjusting bolt		1
3	SI30000145	牛油嘴	Grease Injector	6x1.0 直	1
4	KN140011	支撐塊(一)	Supporting block		1
5	KN140008	滑筒	Tailstock		1
6	KN140009	調整螺栓	Adjusting bolt		1
7	SA10000010	止推滾珠軸承	Thrust ball bearing	51102	1
8	KN14006	固定塊	Fixed plate		1
9	KN140020	銅襯	Bronze bushing		1
10	KN140010	調整旋鈕	Adjusting boss		1
11	SD800350	墊圈	Washer	φ 5/16"	1
12	SD01001077	沉頭內六角螺絲	Hex. socket screw	M6x1x20L	1
13	KN140015	固定塊	Fixed plate		1
14	SH013850	油封:TC規格	Oil seal	TC16. 28. 7	1
15	KN140016	調整螺栓	Adjusting bolt		1
16	KB141105	調整旋鈕	Adjusting Knob		1
17	KN140018	固定塊	Fixed plate		1
18	SD810070	平墊圈	Flat Washer	M14	1
19	KN023100	固定螺絲	Fixed screw		1
20	KN140013	固定棒	Fixed plate		1
21	SH010400	油封:TC規格	Oil seal	TC32. 48. 8	1
22	KN140014	支撐塊	Supporting block		1
23	KN140012	支撐座	Supporting seat		1

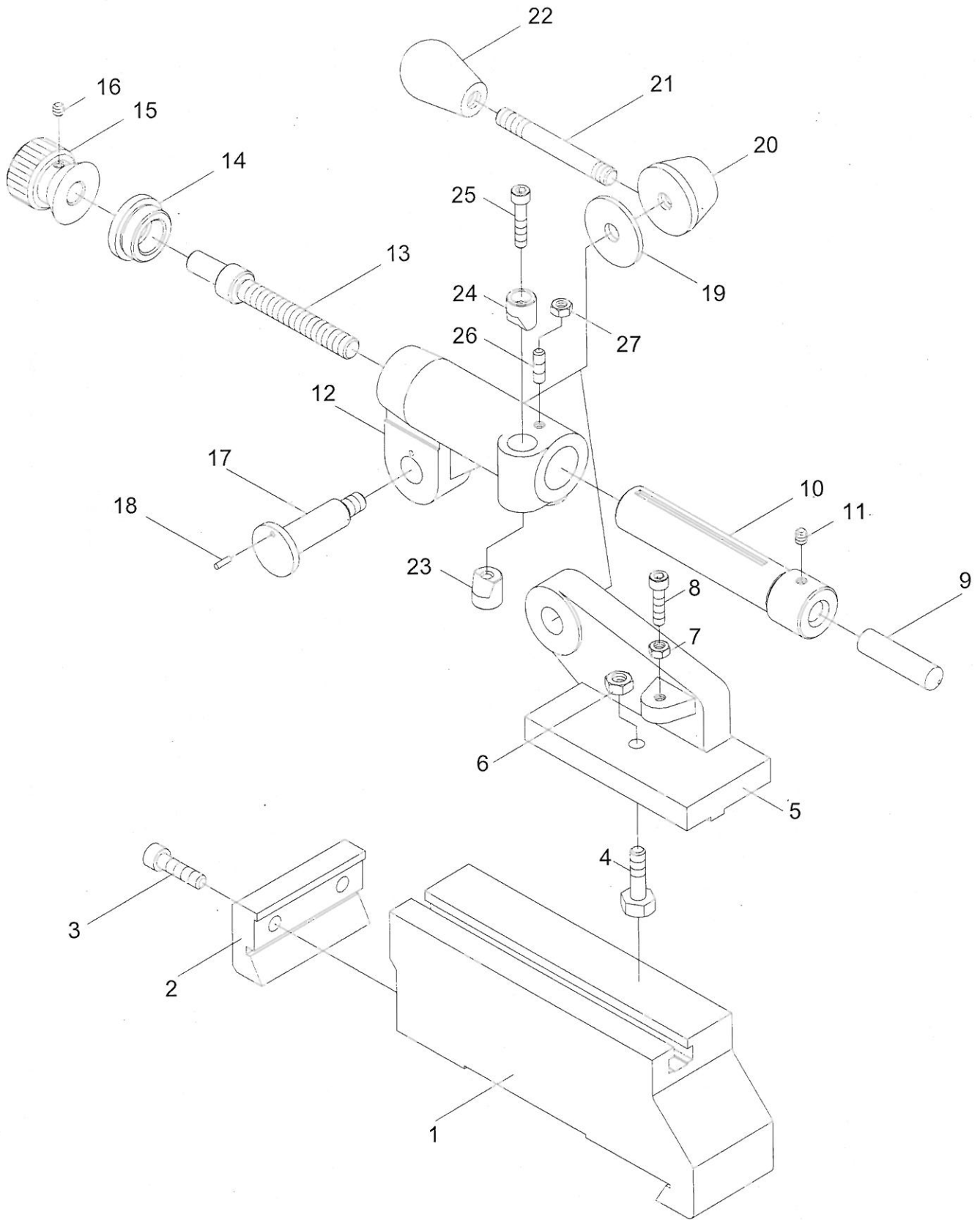

Sharp Industries, Inc.	圖名 (NAME) 內孔研磨裝置 I.D. Dresser(OPT)	核准 (APPROVE) 沈世傑	日期 (DATE) 2003.06.09	圖號 (NUMBER) PB140320
------------------------	---------------------------------------	---------------------	-------------------------	-------------------------

圖號(NUMBER):	PB140320
圖名(DRAWING):	內孔磨修整裝置 - 1 (選購)
	I.D. DRESSER (OPT)
日期 DATE):	2003.06.09
頁數(PAGE):	1-1

NO.	件號/Parts No.	件名	Description	Remarks	Qty.
1.	KN140609	T槽底座	T-Slot base	(G32P)	1
1.	KN140702	T槽底座(加高型)	T-Slot base	(G38P)	1
2.	KB141301	固定塊	Fixed plate		1
3.		內六角螺絲	Socket screw	M8x1.25x25L	2
4.	K4030906	T型螺栓	T-Slot bolt		1
5.	KB145006	中滑座	Adjusting seat		1
6.		六角螺帽	Hexagon nut	M8	1
7.		六角螺帽	Hexagon nut	M6	1
8.		內六角螺絲	Socket screw	M6x1x25L	1
9.	SS330024	單點鑽石修刀	Diamond dresser	#10	1
10.	KB144706	滑筒	Sleeve		1
11.		無頭螺絲	Headless screw	M6x1x8L	1
12.	KB144500	滑筒座	Sleeve seat		1
13.	KB144809	調整螺栓	Adjusting bolt		1
14.	KB144603	固定螺帽	Setting nut		1
15.	KB144902	旋鈕	Fixed knob		1
16.		無頭螺絲	Headless screw	M6x1x6L	1
17.	KB145109	鎖緊螺栓	Lock bolt		1
18.		平行銷	Pin	φ 3x8L	1
19.	KB145202	墊片	Washer		1
20.	KB145305	旋鈕	Knob		1
21.	KB145408	把手	Handle		1
22.		塑膠珠	Plastic knob	M10x1.5	1
23.	KB032508	下固定塊	Lower plunger		1
24.	KB032601	上固定塊	Upper plunger		1
25.		內六角螺絲	Socket screw	M6x1x30L	1
26.		無頭螺絲	Headless screw	M6x1x10L	1
27.		六角螺帽	Hexagon nut	M6	1

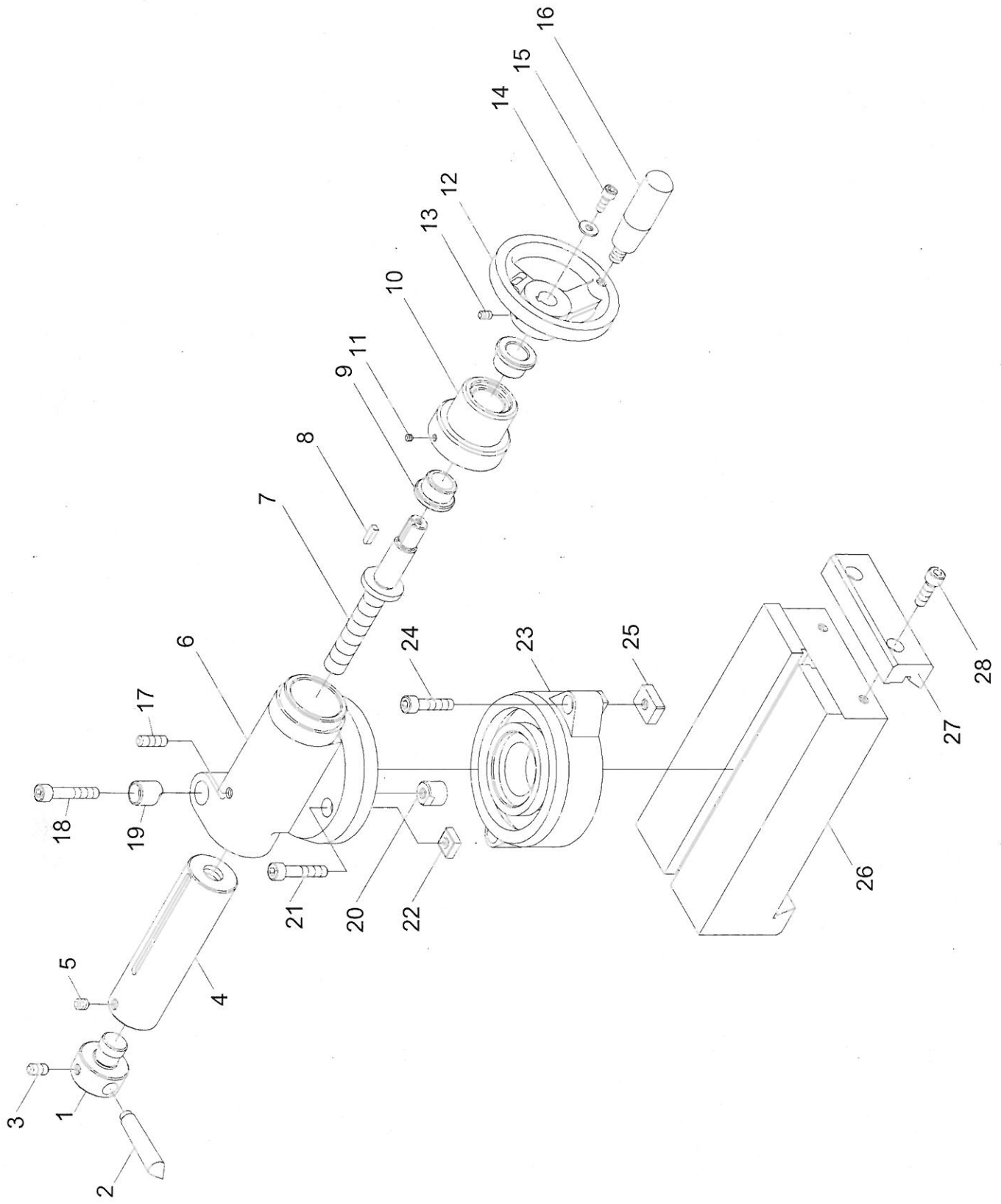

Sharp Industries, Inc.	圖名 (NAME) 角度修整裝置(選購) Angular dresser(OPT)	核准 (APPROVE) 沈世傑	日期 (DATE) 2003.06.09	圖號 (NUMBER) PB140420
------------------------	--	---------------------	-------------------------	-------------------------

圖號(NUMBER):	PB140420
圖名(DRAWING):	角度修整裝置(選購) ANGULAR DRESSER (OPT)
日期 DATE):	2003.06.09
頁數(PAGE):	1-1

NO.	件號/Parts No	件名	Description	Remarks	Qty.
1.	KB143200	固定座	Dresser serat		1
2.	SS330048	單點鑽石修刀	Diamond tool	#20	1
3.	SD030953	無頭螺絲	Headless screw	M8×1.25×16L	1
4.	KB143107	滑筒	Sleeve		1
5.	SD030939	無頭螺絲	Headless screw	M8×1.25×10L	1
6.	KB143004	滑筒座	Slide sleeve seat		1
7.	KB143303	調整螺栓	Adjusting bolt		1
8.	SE110048	單圓頭鍵	Key	5×5×16L	1
9.	KB143406	銅襯	Brass		2
10.	KB143509	固定法蘭	Fixed hub		1
11.	SD030317	無頭螺絲	Headless screw	M5×0.8×6L	3
12.	KA086002	手輪	Hand wheel		1
13.	SD030647	無頭螺絲	Headless screw	M6×1×10L	1
14.	SD800035	墊圈	Flat washer	M6	1
15.	SD011053	內六角螺絲	Socket screw	M6×1×16L	1
16.	SE630075	活動螺絲把手	Handle	5/16"	1
17.	SD030960	無頭螺絲	Headless screw	M8×1.25×20L	1
18.	SD011589	內六角螺絲	Socket screw	M8×1.25×35L	1
19.	KB143602	固定塊(一)	Fixed plate(1)		1
20.	KB143705	固定塊(二)	Fixed plate(2)		1
21.	SD011606	內六角螺絲	Socket screw	M8×1.25×40L	2
22.	KB143808	T型螺帽	T-nut		2
23.	KB143901	旋轉座	Turret base		1
24.	SD011589	內六角螺絲	Socket screw	M8×1.25×35L	2
25.	KB032704	固定塊	Fixed plate		2
26.	KN141105	角度修整底座	Dressing base	(G32P)	1
	KN141301	角度修整底座(加高型)	Dressing base	(G38P)	1
	KN524600	角度修整底座(加高型)	Dressing base	(G50P)	1
27.	KB144108	固定塊	Fixed plate		1
28.	SD011558	內六角螺絲	Socket screw	M8×1.25×25L	2

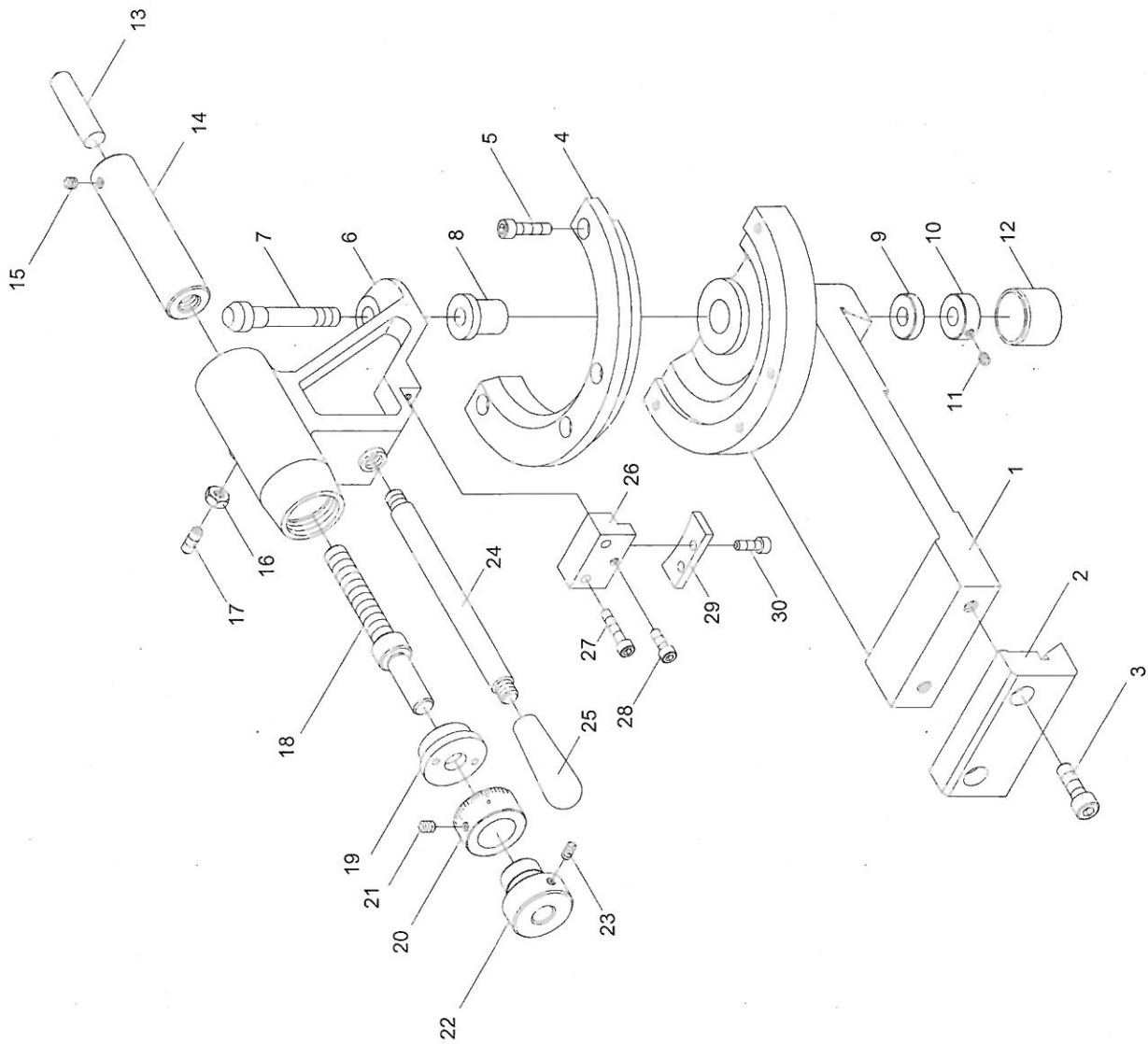

Sharp Industries, Inc.	圖名 (NAME) 弧度修整裝置(選購)Radius wheel dresser(OPT)	核准 (APPROVE) 沈世傑	日期 (DATE) 2003.06.09	圖號 (NUMBER) PB140520
------------------------	--	---------------------	-------------------------	-------------------------

圖號(NUMBER):	PB140520
圖名(DRAWING):	弧度修整裝置(選購) ANGULAR DRESSER (OPT)
日期 DATE):	2003.06.09
頁數(PAGE):	1-1

NO.	件號/Parts No.	件名	Description	Remarks	Qty.
1.	KN141208	圓弧修整底座	Radius dressing base	(G32P)	1
	KN141404	圓弧修整底座(加高型)	Radius dressing base	(G38P)	1
	KN142500	圓弧修整底座	Radius dressing base	(G45P)	1
	KN142400	圓弧修整底座	Radius dressing base	(G50P)	1
2.	KB147400	固定塊	Fixed plate		1
3.		內六角沉頭螺絲	Socket screw	M8×1.25×25L	2
4.	KA086404	支持塊	Supporting seat		1
5.		內六角沉頭螺絲	Socket screw	M6×1×25L	4
6.	BB140104	圓弧修整座	Radius dressing base		1
7.	KA086600	固定螺栓	Fixed bolt		1
8.	KA086703	銅襯	Brass		1
9.	KA086806	銅墊圈	Bronze washer		1
10.	KA087405	螺帽	Nut		1
11.		無頭螺絲	Headless screw	M5×0.8×6L	2
12.	KA086909	護罩	Guard		1
13.	SS330048	單點鑽石修刀	Diamond dresser	#20	1
14.	KA087003	滑筒	Sleeve		1
15.		無頭螺絲	Headless screw	M6×1×6L	1
16.		六角螺帽	Hexagon nut	M6×1	1
17.		無頭螺絲	Headless screw	M6×1×16L	1
18.	KA087106	調整螺栓	Adjusting bolt		1
19.	KB144603	固定螺帽	Fixed nut		1
20.	KA087209	刻度環	Dial ring		1
21.		無頭螺絲	Headless screw	M5×0.8×8L	2
22.	KA087302	旋鈕	Knob		1
23.		無頭螺絲	Headless screw	M5×0.8×10L	2
24.	KA087508	把手	Handle		1
25.		油珠把手	Plastic knob	3/8"-16NC	1
26.	KA086301	支持塊	Supporting seat		1
27.		內六角沉頭螺絲	Socket screw	M5×0.8×25L	2
28.		內六角沉頭螺絲	Socket screw	M5×0.8×16L	1
29.	KA086208	支持塊(二)	Supporting seat (2)		1
30.		內六角沉頭螺絲	Socket screw	M5×0.8×16L	2

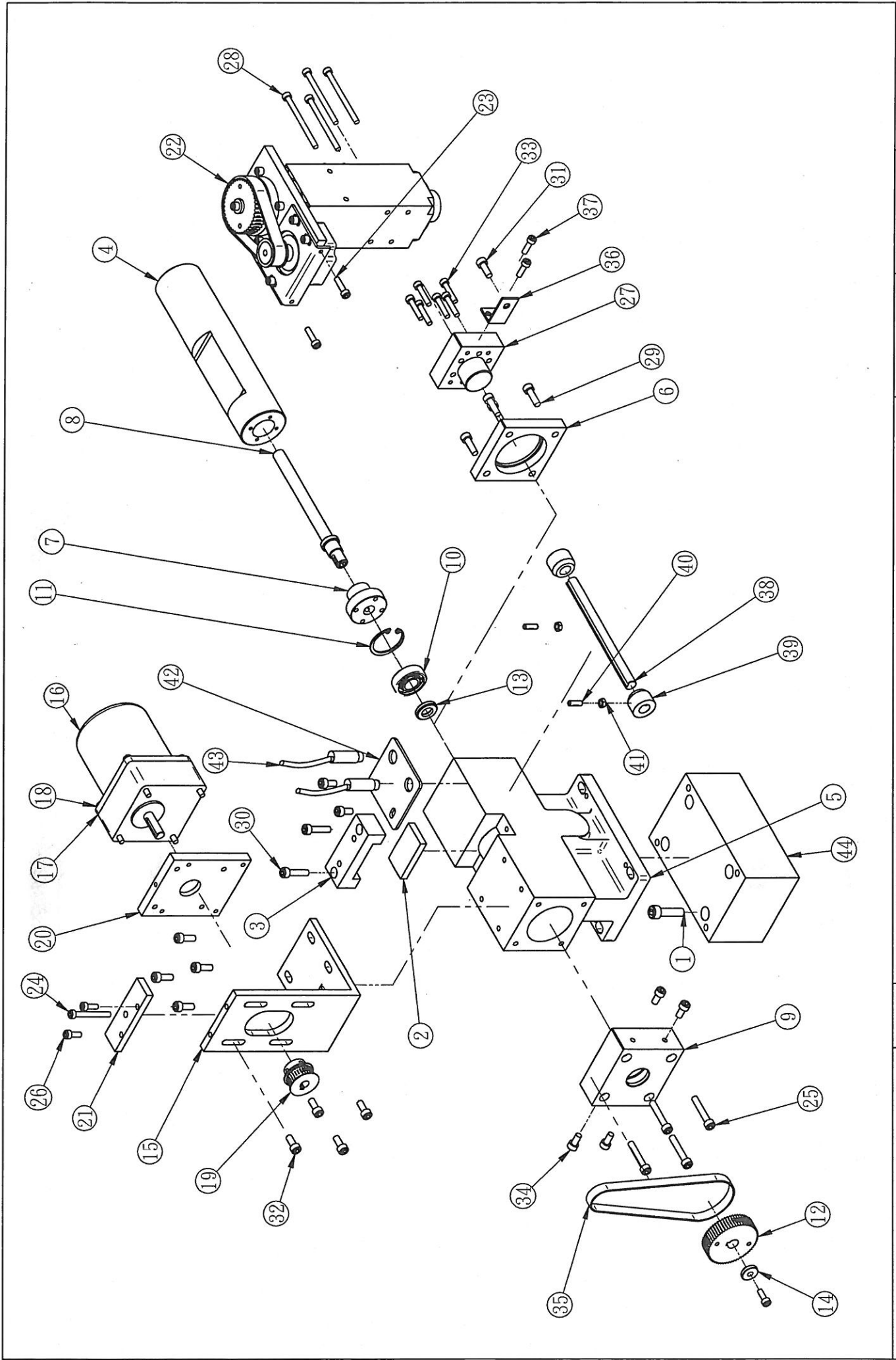

圖名 (NAME) 自動平型整輪(選項) Auto motorized dressing attachment with dressing compensation	核准 (APP) 沈世傑	日期 (DATE) 2005/7/14	圖號 (NUMBER) AL140120
--	-----------------	------------------------	-------------------------



圖號 (NUMBER)	AL140120
圖名 (DRAWING)	自動平型整輪(選項)
	Auto motorized dressing attachment with dressing compensation
日期 (DATE)	2005/7/14
頁數 (PAGE)	1-3

NO.	Parts No.	件名	Description	Remarks	Qty.
1	SD011565	沉頭內六角螺絲	HEX. SOCKET SCREW	M8X1.25X30L	1
2	SZ311016-2				1
3	SZ311016-3	平行修整裝置(mm)	Parallel Dressing Attachment(mm)	E300-mm	1
4	K5317510	自動修砂套筒	HOUSING		1
5	SZ311016-7	修砂座本體	DIAMOND DRESSER ATTACHMENT		1
6	SZ311016-6				1
7	K2	T型螺絲	FG		1
8	K5317310	自動修砂螺桿	BALLSCREW		1
9	K5318200	軸承座	BEARING SEAT		1
10	SA000237	滾珠軸承	BALL BEARING		1
11	SE3100	C型內扣環	INNER RETAINING RING	C35	1
12	K5318000	大皮帶輪	PULLEY		1
13	K5317900	墊塊	BLOCK		1
14	K5318100	大皮帶輪鎖緊墊塊	PULLEY SETTING WASHER		1
15	K5317700	馬達調整固定板	MOTOR ADJUSTING FIXED PLATE		1
16	TL M425-412	馬達	Motor		1
17	SZ311016-17	平行修整裝置(mm)			1
18	SD010739	沉頭六角孔螺絲	HEX. SOCKET SCREW	M5X0.8X50L	4
19	K5317800	小皮帶輪	PULLEY		1
20	K5317600	馬達固定板	MOTOR FIXED PLATE		1
21	K5318400	調整螺絲固定板	ADJUSTING SCREW FIXED PLATE		1
22	SZ390001	修砂頭	DIAMOND DRESSER HEAD		1
23	SD010674	沉頭內六角螺絲	HEX. SOCKET SCREW	M5x0.8x20L	2
24	SD010722	沉頭內六角螺絲	HEX. SOCKET SCREW	M5X0.8X45L	1
25	SD011118	沉頭六角孔螺絲	HEX. SOCKET SCREW	M6x1x35L	4
26	SD010643	沉頭內六角螺絲	HEX. SOCKET SCREW	M5xP0.8x12L	3

圖號 (NUMBER)	AL140120
圖名 (DRAWING)	自動平型整輪(選項)
	Auto motorized dressing attachment with dressing compensation
日期 (DATE)	2005/7/14
頁數 (PAGE)	2-3

NO.	Parts No.	件名	Description	Remarks	Qty.
27	K5317200	修砂頭固定塊	BLOCK		1
28	SD010777	沉頭內六角螺絲	HEX. SOCKET SCREW	M5xP0.8x70L	4
29	SD011077	沉頭內六角螺絲	HEX. SOCKET SCREW	M6X1X20L	4
30	SD011084	沉頭內六角螺絲	HEX. SOCKET SCREW	M6X1X25L	2
31	SD011053	沉頭內六角螺絲	HEX. SOCKET SCREW	M6X1X16L	5
32	SD011046	沉頭內六角螺絲	HEX. SOCKET SCREW	M6X1X14L	4
33	SD010681	沉頭內六角螺絲	HEX. SOCKET SCREW	M5X0.8X25L	6
34	SD011046	沉頭內六角螺絲	HEX. SOCKET SCREW	M6X1X12L	6
35	402-3GT	皮帶	BELT	3GT-402	1
36	K5319300	支架	BRACKET		1
37	SD010650	沉頭內六角螺絲	HEX. SOCKET SCREW	M5x0.8x16L	2
38	K4018600	接桿	SHAFT		1
39	BM031208	極限塊	Limit block		2
40	SD030355	固定螺絲	SETTING SCREW	M5x0.8x16L	2
41	SD020002 0	六角頭螺帽	NUT		2
42	K4018700	固定板	BRACKET		1
43		微動開關	Limit switch		2
44	BL013700	墊塊	Block		1

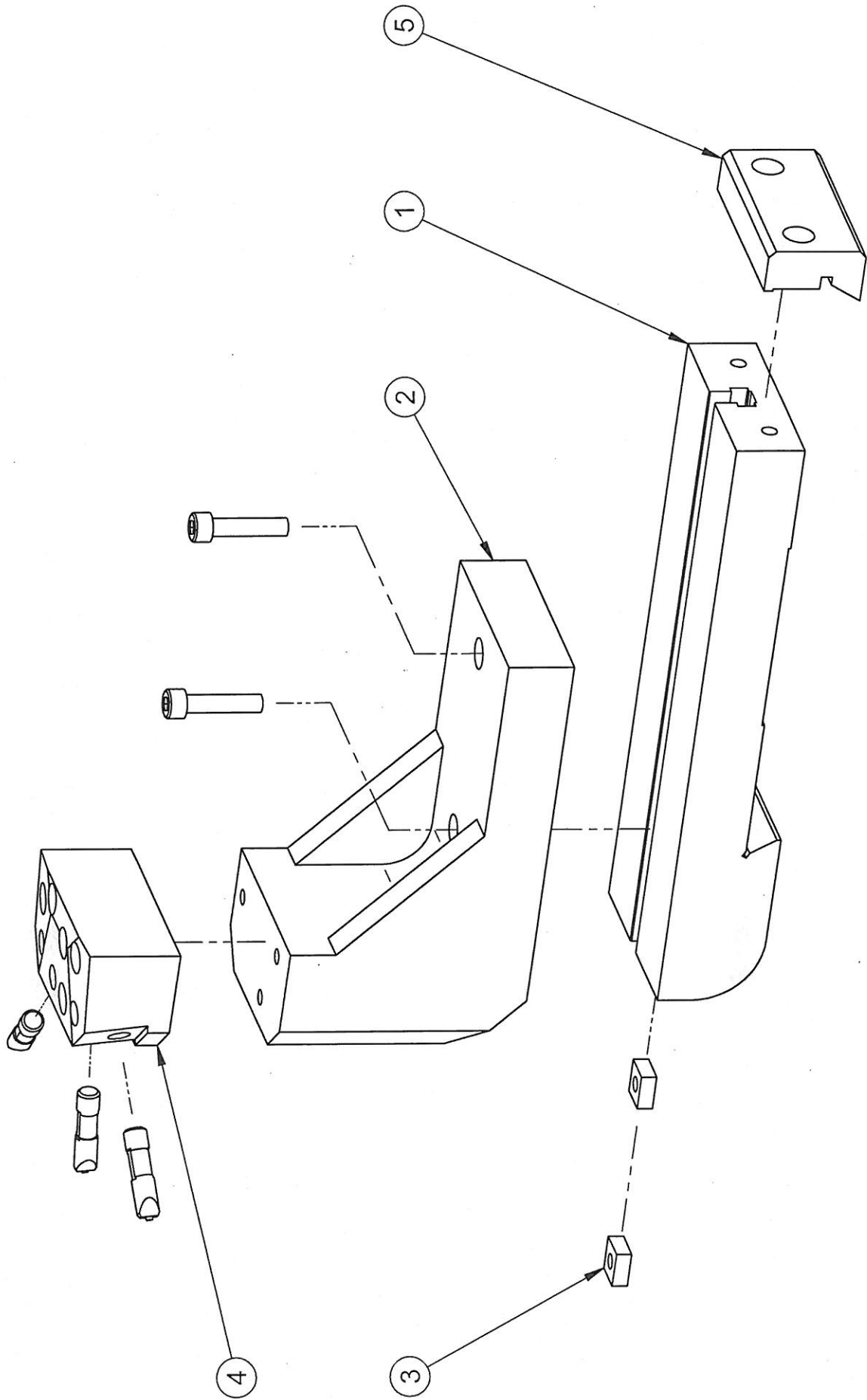

Sharp Industries, Inc.	圖名 (NAME)	活動式修砂座(選購) Adjustable dresser stand (Optional)	核准 (APP)	日期 (DATE)	圖號 (NUMBER)
			林榮涼	2012/6/25	AN144700

圖號 (NUMBER)	AN144700
圖名 (DRAWING)	活動式修砂座(選購)
	Adjustable dresser stand (Optional)
日期 (DATE)	2012/6/25
頁數 (PAGE)	1-1

NO.	Parts No.	件名	Part name	規格(spec.)	用量
1	KN144700	修砂固定座	Cobble sand fixed seat		1
2	KN144800	修砂座	Cobble sand seat		1
3	KB143808	T型螺帽	T-nut		2
4	KJ366400	鑽石筆座	Dresser stand		1
5	KB148607	固定塊	Block		1

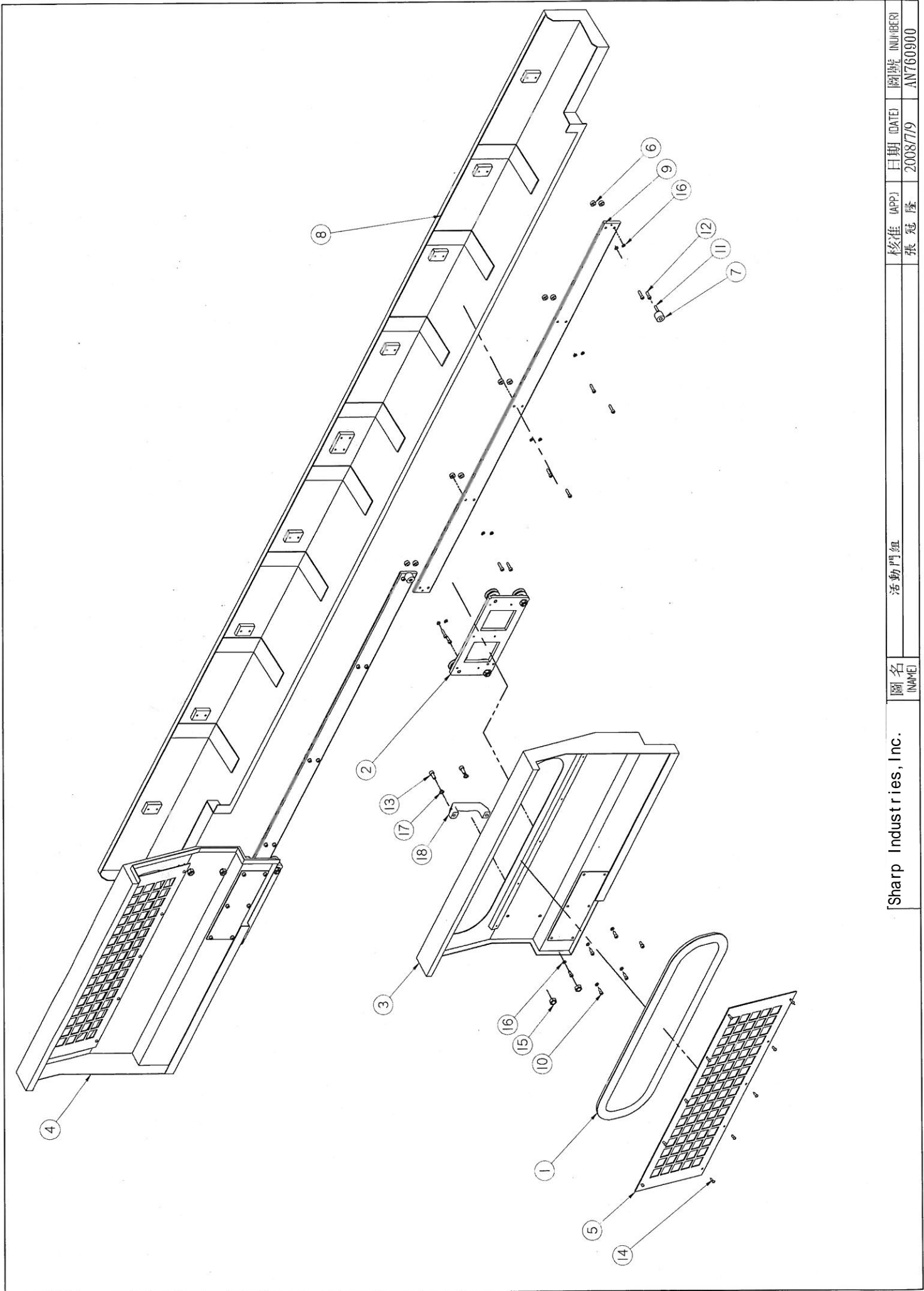

圖號 (NUMBER)	AN760900
圖名 (DRAWING)	活動門組
日期 (DATE)	2008/7/9
頁數 (PAGE)	1-1

NO.	Parts No.	件名	Description	Remarks	Qty.
1					2
2	AF066905	活動門用滑輪組	Sliding Door wl wheels		2
3	KD060507	活動門左 (C.E)	Movable Door (Left)		1
4	KD060600	活動門右(C.E)	Movable Door (Right)		1
5	KD06080	護網 (C.E)	Protecting Net		2
6	KF066802	墊圈(二)	WASHER(2)		20
7	KN064400	緩衝塊	Block		4
8	KN760900	前護蓋	Front Cover		1
9	KN761000	軌道	Slide Way		2
10	SD011053	六角承窩頭螺絲	Hex. Socket Screw	M6x1.0x16mm	12
11	SD011077	六角承窩頭螺絲	HEX. Socket Screw	M6x1.0x20mm	20
12	SD011077	六角承窩頭螺絲	HEX. Socket Screw	M6x1.0x20mm	4
13	SD011541	六角承窩頭螺絲	HEX. Socket Screw	M8x1.25x20mm	4
14	SD040345	圓頭螺絲	ROUND HEAD SOCKET SCREW	M5X0.8X12L	20
15	SD200068	外六角螺帽	HEX. HEAD NUT	M12X1.75	4
16	SD810032	彈簧墊圈	Spring Washer	M06	32
17	SD810049	彈簧墊圈	Spring Washer	M8	4
18	SE630150	把手	Handle Bar		2

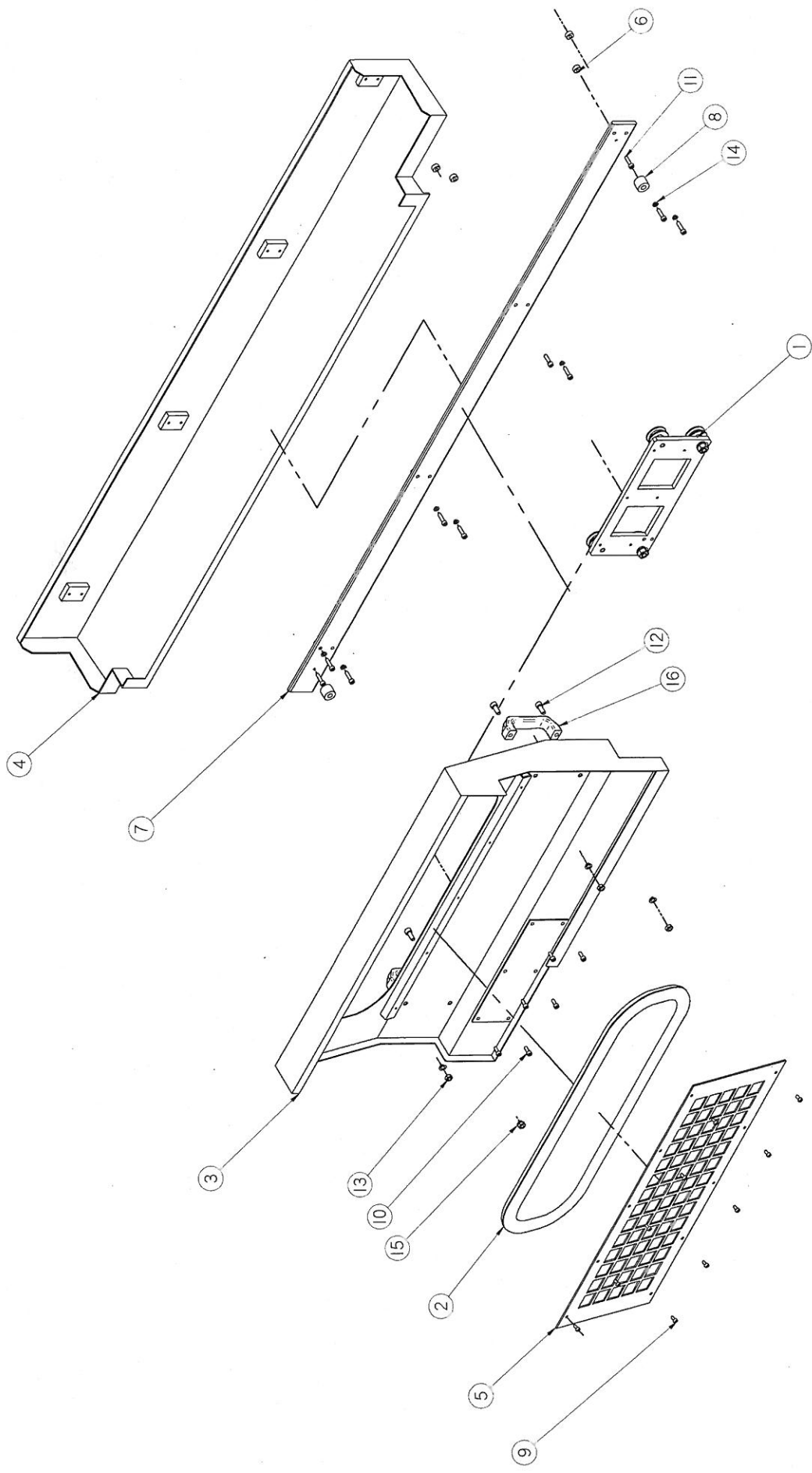

圖名 (NAME)	圖號 (NUMBER)	日期 (DATE)	核准 (APP)	圖號 (NUMBER)
Sharp Industries, Inc.	0D-24 I-活動門組	2008/7/9	張冠隆	AN061100

圖號 (NUMBER)	AN061100
圖名 (DRAWING)	OD-24 -活動門組
日期 (DATE)	2004/12/10
頁數 (PAGE)	1-1

NO.	件號(Part number)	件名	Part name	規格	個數
1	AF066905	活動門用滑輪組	Sliding Door wl wheels		1
2	KB064518	活動門(玻璃窗)			1
3	KB064518	活動門(C.E)	Movable door		1
4	KB067614	前護蓋	Front cover		1
5	KB068309	護網 (C.E)	Protecting net		1
6	KF066802	墊圈(二)	WASHER(2)		8
7	KN064300	軌道	Slideway		1
8	KN064400	緩衝塊	Buffer		2
9	SD010674	六角承窩頭螺絲	Screw	M5x0.8x20mm	10
10	SD011053	六角承窩頭螺絲	HEX. Socket Screw	M6X1.0X16	6
11	SD011077	六角承窩頭螺絲	HEX. Socket Screw	M6x1.0x20mm	10
12	SD011541	六角承窩頭螺絲	HEX. Socket Screw	M8x1.25x20mm	4
13	SD200044	外六角螺絲帽	Nut	M8x1.25	4
14	SD810032	彈簧墊圈	Spring Washer	M06	8
15	SD810049	彈簧墊圈	Spring Washer	M8	4
16	SE630150	把手	Handle Bar		2



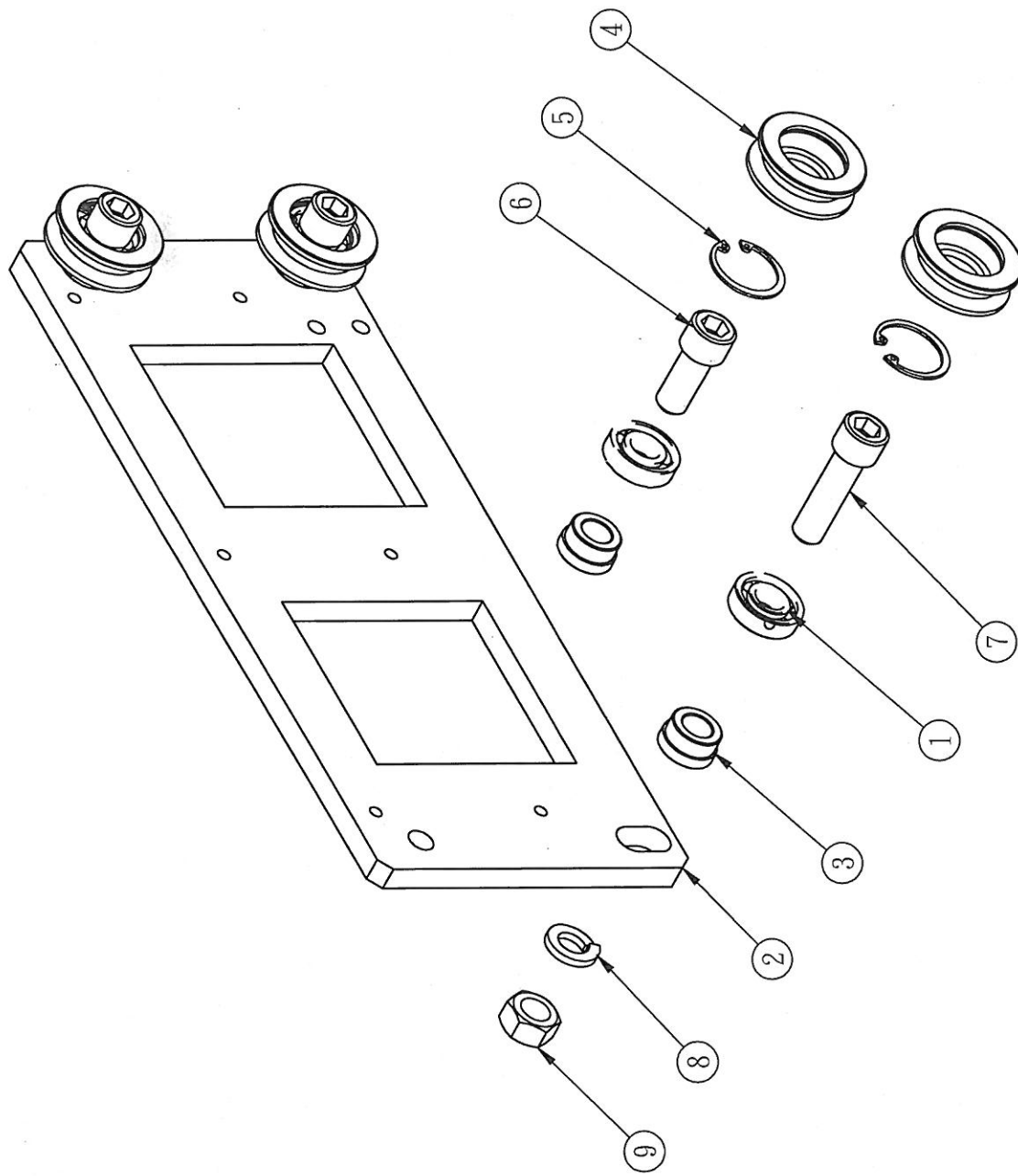

Sharp Industries, Inc.	圖名 (NAME)	活動門用滑輪組 Sliding Door w/ wheels	核准 (APP.) 張冠隆	日期 (DATE) 2008/07/09	圖號 (NUMBER) AF0666905
------------------------	--------------	-----------------------------------	------------------	-------------------------	--------------------------

圖號 (NUMBER)	AF066905
圖名 (DRAWING)	活動門用滑輪組
	Sliding Door wl wheels
日期 (DATE)	2008/7/1
頁數 (PAGE)	1-1

No.	件號 (Part number)	件名	Part name	規格 (spec.)	個數
1	SA001324	單列深槽滾珠軸承	Ball Bearing	6001ZZ	4
2	KF066905	固定座	Fixed Seat		1
3	KF066709	墊圈(一)	Washer		4
4	KF066606	滾輪	Roller Wheel		4
5	SE310060	C型內扣環	INNER RETAINING RING	C28	4
6	SD012449	六角沉頭螺絲	HEX. Socket Screw	M12x1.75x30mm	2
7	SD012470	六角沉頭螺絲	HEX. Socket Screw	M12x1.75x45mm	2
8	SD810056	彈簧墊圈	Spring Washer	M12	2
9	SD200068	外六角螺帽	HEX. HEAD NUT	M12X1.75	2